

NELSON TASMAN LAND DEVELOPMENT MANUAL

September 2020
Revision 1



Nelson Tasman Land Development Manual

Foreword

This is the first joint Nelson Tasman Land Development Manual (NTLDM). It replaces the Tasman District Council Engineering Standards 2013 and the Nelson Land Development Manual 2010, and provides one set of standards for the Nelson and Tasman regions.

The NTLDM is a document that combines network asset design and construction requirements for both Nelson and Tasman regions. It also includes formation and construction standards for some private assets that connect to network assets.

The NTLDM is intended to provide consistent minimum standards and guidance for network assets that Council will accept as part of its network, and activities affecting them including maintenance and operations. The aim is to achieve the right balance between durable, cost effective, environmentally sustainable and fit-for-purpose infrastructure for our communities.

The Manual has been developed in consultation with a range of stakeholders including key staff from both councils, a steering group including Councillors and external advisers, and with input from surveyors, developers, consultants, network utility owners, walking/cycling groups, industry training organisations, suppliers and contractors.

This manual includes some significant changes or additions to the previous Nelson Land Development Manual and Tasman's Engineering Standards. In particular, changes have been made to the way roads are designed and how we manage stormwater.

Nelson City Council and Tasman District Council encourage innovative and sustainable design and welcome alternative solutions to this Manual where this will achieve better results.

The NTLDM will be regularly reviewed and amended to reflect changes in land development practice and feedback from stakeholders. Revision one has now been updated with feedback from stakeholders.

Council has also developed a series of Practice Notes associated with the NTLDM. They provide guidance on achieving best practice, and include:

- Stormwater Inundation Practice Note – providing best practice for calculating minimum ground and/or floor levels for subdivision, new buildings and major alterations.
- Bioretention Practice Note – developed specifically for stormwater management with an emphasis on environmental protection and the mitigation of development-related impacts on flooding and surface waterways, including reducing peak flows, reducing spills and reducing water pollution.
- Wetland Practice Note – intended to primarily support the design and delivery of constructed wetlands for stormwater treatment for water quality improvements.

The councils consider this an important document for delivering the shared goals for affordable and resilient asset management while balancing community expectations for our environment.



Cr Tim King
 Chair, Nelson Tasman Land Development Manual Steering Group



Chapter 1

Introduction and General Provisions

TABLE OF CONTENTS

CHAPTER 1 INTRODUCTION

1	GENERAL	1
1.1	Purpose	1
1.2	Outline of Document.....	2
1.3	The Standards	2
1.4	Statutory Requirements.....	3
1.5	Applicability.....	3
1.6	Document Control.....	3

CHAPTER 1 INTRODUCTION

1 GENERAL

This document is the Nelson-Tasman Land Development Manual 2020 (Revision 1) (NTLDM) and contain revisions and corrections noted within the 2019 version.

The NTLDM is a document that combines network asset design and construction requirements for both Nelson and Tasman regions. It is intended to provide consistent minimum standards and guidance for network assets that Council will accept as part of its network, and activities affecting them including maintenance and operations. It also includes formation and construction standards for some private assets that connect to network assets.

The NTLDM replaces former Engineering Standards, the Nelson Land Development Manual, and the Tasman District Engineering Standards.

The relationship of the NTLDM to asset management functions under the Local Government Act (2002) and resource management functions of Council under the Resource Management Act (1991) is important.

All development within Nelson and Tasman must be consistent with the requirements of the respective Resource Management Plans (RMPs), being the Tasman RMP and the Nelson RMP. Development must be consistent with applicable RMP rules, either by meeting conditions for permitted activities or by applying for and gaining a resource consent.

However, where a new Council network asset is being created, maintained, or replaced through development, such as a new road or water supply pipeline, it is the NTLDM that provides more detailed design and construction standards of what the Councils will accept and take over as a public asset. Additionally, practice notes provide comprehensive design details that can support developers and maintenance and operation contractors in carrying out their activities in a way that will meet Council's expectations for design and construction. Altogether, these can also aid the Councils in achieving levels of service that are set out in Long Term Plans and objectives of the RMP's.

Parts of the NTLDM are externally referenced provisions of the Nelson Resource Management Plan or Tasman Resource Management Plan, where specified in those plans. The specified parts will be subject to First Schedule requirements of the Resource Management Act as "externally referenced" standards.

1.1 Purpose

The purpose of the NTLDM is to provide standards and guidance for the design, construction, maintenance, repair and replacement of:

- network assets and infrastructure that are or will be owned by the Councils; and
- some private assets that connect to public assets.

The standards aim to ensure the effective and efficient provision of infrastructure and environmental requirements.

The performance outcomes that the Councils seek to achieve are:

- a) A standard of service that ensures the health, safety and wellbeing of people and communities;
- b) Network assets and infrastructure that are designed to avoid or minimise risks associated with natural hazards and climate change effects, with particular regard for lifeline networks;
- c) The delivery of services to levels set out in the Long Term Plan (LTP);
- d) Assets and infrastructure that meet obligations for the sustainable management of natural and physical resources;

- e) The delivery of environmental outcomes that are consistent with the objectives of the RMPs;
- f) The effective and efficient provision of network utilities and infrastructure, with Network Utility providers responsible for telecommunications, electricity and transportation;
- g) Network infrastructure that is affordable over the whole-of-life of the asset; and
- h) Innovative water sensitive design and good urban design solutions, where network performance and cost effectiveness goals can be met.

1.2 Outline of Document

The NTLDM is organised into three parts.

Part I Introduction (Chapters 1-3)

This sets out how the document will be used, how it relates to other functions of Council, and its legal context. It also contains general provisions that apply to all sections of the document, including process requirements, engineering design details required and definitions.

Part II Standards (Chapters 4-10)

These chapters contain all standards, both mandatory ones and those that indicate what Council considers to be good practice. These are intended for network asset creation, maintenance, repair and replacement, and they are organised in terms of each asset, such as “Stormwater”, “Transportation” and “Water”. As well as the standards themselves, each chapter also sets out performance outcomes, tabulates other important standards relevant to that asset and summarises cross references to the respective RMPs.

Part III Appendices

The Appendices cover additional guidance forms and checklists. Associated with this manual are Practice Notes which contain detailed guidance about “acceptable solutions”, giving more practical guidance on the design and construction of solutions and devices that Council will accept as part of its network.

1.3 The Standards

The standards themselves are set out according to relevant design or construction consideration and broken down into two broad groupings being “mandatory” and “good practice” matters.

Mandatory matters are those which are a benchmark standard for design or construction that Council will accept. They represent a “line in the sand” that can help to ensure that Council-defined levels of service will met. They also provide a clear pathway for acceptance and certainty for developers and contractors.

However, both Councils recognise that in some situations the standards might not be the best way to achieve the performance outcomes sought, due to the particularities of the site or situation. Council also accepts that some design outcomes cannot easily be achieved by the application of a minimum standard. For these reasons “good practice” matters are also provided.

These are intended to provide a blend of additional guidance and direction such as; indicators of preferred methods, design formulae, matters for the exercise of discretion and general information. Where good practice matters are applied in design or construction, it is the performance outcomes sought that will ultimately determine what will be acceptable to Council.

Where there is a divergence from mandatory requirements, additional information and engineering design detail may be required by Council at the time of engineering plan approval or application for resource consent. Council will exercise discretion around the acceptability of any non-standard design and, depending on the relevant process, consider the design against the objectives and policies of the relevant RMP and the applicable performance outcomes of the NTLDM.

In the case of the Stormwater chapter, the associated practice notes are also provided to guide the design of specific stormwater management solutions. They are acceptable solutions for meeting mandatory requirements of the stormwater standards.

1.4 Statutory Requirements

The provisions of the NTLDM must be read subject to the provisions of the respective Councils' RMP's and to any applicable statutes, regulations, and bylaws.

The main statutes that the NTLDM relates to are:

- Resource Management Act 1991;
- Building Act 2004;
- Local Government Act 2002;
- Land Transfer Act 1952;
- Unit Titles Act 1972;
- Property Law Act 1952;
- Housing Accords and Special Housing Areas Act 2013; and
- Heritage New Zealand Pouhere Taonga Act 2014

Requirements from each legislative document provide consent authorities with the powers and functions to request, provide, and supply information pertaining to the land.

In addition, Councils' obligations for natural hazards management, including consideration of climate change are reflected in the NTLDM standards. Requirements for design, materials and construction standards generally have been set to minimise risks where possible and build network resilience.

Regarding Iwi liaison and consultation, developers and contractors shall be made aware of their obligations under the Resource Management Act 1991, the Local Government Act and the New Zealand Pouhere Taonga Act 2014.

1.5 Applicability

As noted above, all development is subject to the requirements of the respective RMPs.

In respect of network assets, this document applies in the following ways:

- a) All infrastructure assets that are to be vested in Council.
- b) All infrastructure assets constructed under contract for Council.
- c) The maintenance, repair, and replacement of existing infrastructure.
- d) Any development or infrastructure assets that may connect to, or have an impact on, Council's infrastructure assets.

1.6 Document Control

The NTLDM is a controlled document and amendment or re-issue is the responsibility of the Council Engineering Managers with approval of the Council.

Amendments or reviews may be carried out three-yearly. However, an earlier individual amendment may be made if an important alteration to a standard or technology arises. Significant amendments will be reviewed and approved by Council.



Te Kaunihera o
te tai o Aorere



Amendments to some of the mandatory matters of the NTLDM may also be subject to a public notification, submissions and hearings process, in accordance with the First Schedule of the Resource Management Act

An electronic copy of the NTLDM is available via the Councils' websites.



Chapter 2

Qualifications, Process and Information Requirements

TABLE OF CONTENTS

CHAPTER 2	QUALIFICATIONS, PROCESS AND INFORMATION REQUIREMENTS.....	1
INTRODUCTION		1
2	PURPOSE	1
2.1	Requirements for Professional Qualifications and Experience	1
2.1.1	Qualifications and Experience	1
2.2	Infrastructure Development Process	1
	Mandatory Matters	1
2.2.1	General	1
2.2.2	Preliminary Discussion and Design	4
2.2.3	Review and Acceptance of Design Drawings and Supporting Information	4
2.2.4	Construction by Stages.....	4
2.2.5	Neighbours' Consent	5
2.2.6	Notification of Contracts and Phases of Work	5
2.2.7	Pre-construction Meeting.....	5
2.2.8	Commencement of Development Works.....	6
2.2.9	Documentation to be Held	6
2.2.10	Variations	7
2.2.11	Council Inspections and Construction Hold Points.....	7
2.2.12	Completion Certificate and Supply of As-built Drawings	8
2.2.13	Acceptance of As-Built Plans.....	8
2.2.14	Maintenance Certificate	8
2.2.15	Phases and Information Requirements	9
2.3	Information and Data Requirements	9
	Mandatory Matters	10
2.3.1	General	10
2.3.2	Media and Format.....	10
2.3.3	File Structure	11
2.3.4	Layout	12
2.3.5	Orientation of Plans and Sections	12
2.3.6	Size and Scale.....	12
2.3.7	Coordinate System, Datum and Accuracy.....	13
2.4	Design Drawings	13
	Mandatory Matters	13
2.4.1	General	13
2.4.2	Earthworks Design Drawings.....	14
2.4.3	Road/Street Works Design Drawings	14
2.4.4	Wastewater Design Drawings.....	15
2.4.5	Stormwater Design Drawings	15
2.4.6	Water Supply Design Drawings.....	15
2.4.7	Street lighting, Power and Telecommunication Utilities Design Drawings	15
2.5	As-built Plans and Data	16
	Mandatory Matters	16

2.5.1	General	16
2.5.2	As-built Quality.....	16
2.5.3	As- built Coordinate and Attribute Data	16
2.5.4	Coordinate and Elevation Standards	17
2.5.5	Survey Datum	17
2.5.6	Earthworks As-built Drawings.....	17
2.5.7	Road/Street Works As-built Drawings	18
2.5.8	Wastewater As-built Drawings.....	18
2.5.9	Stormwater As-built Drawings	19
2.5.10	Water As-built Drawings	20
2.5.11	Pump Stations and other Electrical Equipment	20
2.6	Other Utilities.....	21

APPENDICES

Appendix A	Engineering Design Drawing and As-built Drawing Approval Process
Appendix B	Design Certificate – Land Development/Subdivision Work
Appendix D	Certification upon completion of Subdivision Work
Appendix E	Nelson and Tasman Vertical Datum's

LIST OF TABLES

Table 2-1	Training Requirements Schedule	3
Table 2-2	The Council's Requirements	9
Table 2-3	Acceptable Format	11

CHAPTER 2 QUALIFICATIONS, PROCESS AND INFORMATION REQUIREMENTS

INTRODUCTION

2 PURPOSE

The purpose of this section is to outline the requirements of designers and construction contractors involved in the design and construction of infrastructure assets and to provide an overview of the approval and authorisation process of the Information and data requirements, relating to the design and construction of new infrastructure and assets.

2.1 Requirements for Professional Qualifications and Experience

This section sets out the minimum qualifications of those involved in the design and construction of infrastructure and assets.

2.1.1 Qualifications and Experience

- 2.1.1.1 The Council requires all design, construction and construction supervision of infrastructural assets and subdivision works to be performed by suitably qualified and experienced individuals.
- 2.1.1.2 Contractors must hold a minimum relevant qualification and training for the proposed design or works in accordance with the Training Requirements Schedule see Table 2-1.
- 2.1.1.3 Contractors must be suitably experienced in the field of work to be undertaken. The Council will request a schedule of qualifications in support of this in advance of any work being undertaken. A Health and Safety training qualification will be a mandatory requirement for all contractors working on existing or future Council infrastructure.

2.2 Infrastructure Development Process

This section sets out the expectations for the process of design and plan preparation and an overview of the approval process. Appendix A shows an overview of the design drawing and as-built drawing approval process.

Mandatory Matters

2.2.1 General

- 2.2.1.1 The Council standards, as set out in this document, are intended to reflect the minimum standard required by the Council and should not be seen as a replacement for professional engineering design.
- 2.2.1.2 The responsibility for site-specific design relies solely on the Designer of the work and this may include investigation of unusual site conditions and exceptional circumstances. The Designer will consider all risks to lifeline systems (significant infrastructure) in the event of a major natural hazard, including but not limited to earthquake, flood, tsunami, slope failure, erosion or inundation, including the effects of climate change.

- 2.2.1.3 At the Design Drawing approval stage, the Designer is required to complete and submit a Designer's Certificate and Check Sheet with the Design Drawings (see Appendix B and Appendix C of this section) together with the Designer's details on the plan title block.
- 2.2.1.4 At the as-built stage, the Developer's Professional Advisor (DPA) is required to certify that the work has been completed in accordance with sound engineering practice and as shown in the as-built information supplied.
- 2.2.1.5 Contractors who intend to work on the Council's live water reticulation will only be permitted to do so if they are authorised by the Council and have submitted the appropriate application and gained approval.

Table 2-1 Training Requirements Schedule

NZQA Qualification Level	National Certificate Minimum Level of Qualification required	Contractor Role	Type of Works
5	Company Owner, Contractor and/or Project Manager/Contractor's Engineer.	One individual employee of the company undertaking the works will be appointed as the 'Project Manager or Contractor's Engineer' in charge of the construction as direct reports for sites of sufficient size and complexity as determined by the Council.	Construction of the Council assets or construction of assets to be vested in the Council. Multiple sites involving multiple disciplines of work.
4	Supervisor	One individual employee onsite will be appointed as the 'Supervisor' and be charged with supervising the construction for the duration of works for sites of sufficient size and complexity as determined by the Council.	Construction of the Council assets or construction of assets to be vested in the Council. Individual sites involving multiple disciplines of work.
4	Technical	Primary individual employee responsible on site for undertaking the technical works must have a relevant qualification relating to task being carried out.	Construction of the Council assets or construction of assets to be vested in the Council. Individual sites involving individual disciplines of work.
3 or demonstrates equivalent ability.	Operator	Primary individual employee responsible on site for undertaking the technical works must have a relevant qualification relating to task being carried out.	Minor utility works, minor excavation works, non-vested works.

Notes:

- 1) Similar non NZQA qualifications may be used as an alternative with the Council approval.
- 2) Expired qualifications to be recognised if the graduate profile meets the requirements of the works.
- 3) The Council retains the right to grant exceptions to the above matrix based upon extent and scale of works.
- 4) The Council retains the right to audit contractor personnel and their qualifications prior to contract award, prior to commencement of works and at any time throughout the duration of works.
- 5) Specific levels and training required are to be communicated by council in tender and contract documents.
- 6) Higher qualifications supersede lower levels eg, if the Supervisor has Level 5 Contract Management, they do not require Level 4 Supervision.

2.2.2 Preliminary Discussion and Design

The Council encourages Designers and the Developers Principal Advisor (DPA) to meet with the Council in the early stages of design to discuss any proposed works and how these will meet the Council's standards and integrate with existing services and infrastructure. Information on how to obtain pre-application advice is available on the Councils' websites or by contacting the Council.

Prior to approval to commence work, the Council requires the submission of fully detailed Design Drawings covering the design of all new roads, rights-of-way, access lots and service utilities. These drawings and associated information will be reviewed by the Council and assessed against the requirements in this document.

2.2.3 Review and Acceptance of Design Drawings and Supporting Information

- 2.2.3.1 Design Drawings and supporting information must be submitted to and approved by the Council prior to the commencement of physical works, and prior to the pre-construction meeting.
- 2.2.3.2 For large subdivisions, full Design Drawings may be required by the Council prior to subdivision consent being granted.
- 2.2.3.3 The requirements of the Design Drawings and supporting information are described in Sections 2.2.15 and 2.4.
- 2.2.3.4 The Council will review the Design Drawings and supporting information and advise the applicant in writing of either:
- a) Acceptance of the Design Drawings, and supporting information; or
 - b) A request to modify the design and/or provide further information.
- 2.2.3.5 Acceptance of the Design Drawings and supporting information will consist of a single copy of each of the Drawings, endorsed with the signature of the Engineering Manager or his/her approved representative.

2.2.4 Construction by Stages

- 2.2.4.1 Where the landowner proposes to proceed with construction of a subdivision in more than one stage, the Design Drawings will cover the whole scheme in the first instance.
- 2.2.4.2 In the case of major staged subdivisions where the Council's infrastructure is involved, the Council, at its sole discretion, may relax this requirement to the extent that preliminary service layout drawings for the total project may be submitted for initial approval.
- 2.2.4.3 Fully detailed Design Drawings required for each particular stage will subsequently be submitted for final approval.
- 2.2.4.4 Design Drawings for each stage will comply with the applicable Land Development Manual at the time of the subdivision consent approval; however, should an extension of time for the consent be granted, compliance with the current Land Development Manual at the time of extension may be required.

2.2.5 Neighbours' Consent

2.2.5.1 Where any construction work is required on another property, written evidence of the owner's consent is required.

2.2.5.2 The Council will need to view any easement document at the as-built plan stage to secure legal access over the affected land.

2.2.6 Notification of Contracts and Phases of Work

2.2.6.1 At least five working days prior to the commencement of work the consent holder or their agent will advise the Engineering Manager in writing of the following information:

- a) The name(s), addresses and contact telephone numbers of contractor(s) to whom it is proposed to award the work;
- b) The nature of the work to be awarded in each case; and
- c) The date that work will commence.

2.2.7 Pre-construction Meeting

2.2.7.1 Where there are assets to vest in the Council, the Developer will arrange a formal pre-construction meeting (with a written agenda) at the Council's offices with the DPA, contractor's site representative, the Engineering Manager or their representative and the Manager Resource Consents/Compliance or their representative.

2.2.7.2 This meeting will occur prior to the commencement of any work and after approval of the Design Drawings and will include discussion of the programme of works, the inspections required by the Council or their agents and any other relevant matters.

2.2.7.3 Specifically, matters to be discussed at this meeting will include:

- a) Type/size of work contemplated and methodology;
- b) Soil types, ground, environmental and weather conditions;
- c) Erosion and sediment control requirements;
- d) Locality of site;
- e) Consent conditions;
- f) Hold points and inspections required by the Council;
- g) Traffic effects, corridor access requests and effects to neighbours;
- h) Risk to adjacent services;
- i) Health and Safety;
- j) Relevant experience/training of the Contractor(s);
- k) Relevant experience of the Designer(s) and the DPA and level of construction supervision;
- l) The potential for accidental discovery of artefacts of cultural heritage significance, and the need for a cultural heritage monitor in accordance with the Heritage New Zealand Pouhere Taonga Act 2014.

2.2.7.4 The Designer/DPA will bring to the pre-construction meeting:

- a) A construction programme;
- b) A full set of approved Engineering Drawings;
- c) The construction specification;
- d) An outline of the proposed construction supervision approach;
- e) Detail of proposed sediment and erosion controls; and,
- f) Any relevant information on how risks, environmental compliance and consent compliance are going to be managed.

2.2.7.5 A letter outlining minutes of the meeting, agreed hold points and the inspection regime will be prepared and distributed by the Council within two working days after the meeting.

2.2.7.6 Site monitoring is at the discretion of the Council, based on the significance and scale of the project and associated risks, and will be discussed at the preconstruction meeting with the Designer/DPA.

2.2.8 Commencement of Development Works

2.2.8.1 Work will not commence on the engineering construction of the subdivision or development unless:

- a) The Council has granted an appropriate resource consent;
- b) There are no outstanding appeals or rights of appeal to the Environment Court;
- c) The Council has approved the Design Drawings, specifications and calculations for the specific work that is required;
- d) The Council has approved the Traffic Management Plan (TMP) (if required);
- e) The Council has approved the Erosion and Sediment Control Plan (ESCP) if required;
- f) All other necessary consents or permits (e.g. corridor access request, building consent) have been obtained; and,
- g) The pre-construction meeting has been held, where appropriate.

2.2.8.2 The Council may grant staged approval to allow earthworks to commence prior to approval of other works at his/her sole discretion, provided that suitable erosion and sediment controls have been implemented, as per the approved Erosion and Sediment Control Plan (ESCP).

2.2.8.3 The Consent holder should be aware that in some cases, the Environment Court has ruled that works must not proceed without the Court's consent in cases where an appeal is lodged against consent conditions and has not been heard, or a right of appeal to the Court still exists, such as in the case of an objection lodged with the Council and still unheard.

2.2.8.4 Work must cease in the event of accidental discovery of archaeological artefacts, in accordance with the Heritage New Zealand Pouhere Taonga Act 2014. An authority must be obtained from Heritage New Zealand (Pouhere Taonga) to modify, damage or destroy a cultural heritage site.

2.2.9 Documentation to be Held

2.2.9.1 Throughout the construction period, the Contractor's site representative will have the following material on site at all times:

- a) Signed copies of the approved Design Drawings and the initial letter from the Council setting out hold points, the inspection regime and engineering administration matters;

- b) A verified Health and Safety Plan and the letter of verification;
- c) Copies of the resource consent;
- d) Copies of any of the Council consents or permits necessary for the works;
- e) Signed copies of all consents to enter land for construction for works on land not owned by the Developer;
- f) Approved plans and details of the sedimentation and erosion control plan to be implemented; and,
- g) An approved traffic management plan from the road controlling authority.

2.2.10 Variations

2.2.10.1 No variations from the approved Design Drawings will be made without the proposed amendments being first submitted to, and approved by, the Council.

2.2.10.2 The Designer will identify and fully document the nature and position of the amendments.

2.2.10.3 In the case of emergencies where immediate action is required to safeguard safety and health, property and infrastructure assets, such action will be taken. At the earliest opportunity after the event, the Council will be notified for approval.

2.2.11 Council Inspections and Construction Hold Points

2.2.11.1 The DPA will notify the Council at least five working days (or as mutually agreed) before any of the following phases of the work are reached (and such other phases as have been determined), to enable inspection to be carried out by the Engineering Manager or representative:

- a) Earthworks starting (for checking of erosion and sediment control measures);
- b) Street Works:
 - i) Subgrade preparation and subsoil drains;
 - ii) Base course prior to sealing;
 - iii) Foot path and kerbside prior to sealing or concreting.
- c) Stormwater and Wastewater:
 - i) Inspection of laying first pipes of pipeline in subdivision while there is work in progress;
 - ii) Inspections at a series of hold points determined by the Engineering Manager or representative to suit the particular situation and level of monitoring
- d) Water Supply:
 - i) Inspection of each line prior to backfill and trench reinstatement, including pressure testing;
 - ii) Chlorination; and
 - iii) Connection by the Council required.
- e) Final:
 - i) After completion of all works including, sweeping of roads and channels, clearing all drains, manholes and sumps, checking all valve and hydrant operations, planting riparian areas and appropriate inspections, eg. CCTV, gauging or any other testing as required by the Council as appropriate.

Note:

- 1) *The certification by the Developer's Professional Advisor of the works at the various stages identified in section 2.2.11;*
- 2) *The Council reserves the right to determine the inspection/monitoring regime on each project and the testing method of services/infrastructure which is appropriate.*

2.2.12 Completion Certificate and Supply of As-built Drawings

- 2.2.12.1 Where requested by the Council a preliminary as-built plan may be required, prior to approval of the survey plan, in order to confirm that the services covered by easements are positioned and aligned correctly within those easements.
- 2.2.12.2 On completion of the construction of a subdivision or development the DPA being a Chartered Professional Engineer or Registered Professional Surveyor, will submit to the Council a Completion Certificate that the work has been constructed in accordance with:
- a) This Nelson Tasman Land Development Manual;
 - b) The accepted Design Drawings and specifications;
 - c) Any resource consent conditions;
 - d) Any accepted amendments; and
 - e) Manufacturer's instructions.
- 2.2.12.3 The "Certifier" may be required to provide sufficient evidence at the written request of the Council to demonstrate to the Council's satisfaction that they have experience and competence in the work they are certifying, that they have sufficient professional indemnity insurance and run-off cover, and they have sufficient documented observation and testing records to adequately certify the works.
- 2.2.12.4 The Works Completion Certificate will be accompanied by as-built drawings, showing all works as actually constructed, and drawn to the drawing standards specified by the Council in Sections 2.4 and 2.5.
- 2.2.12.5 The Works Completion Certificate will be in the form as shown in Appendix D and must be received by the Council before it decides whether to issue a certificate under Section 224(c) of the Resource Management Act.

2.2.13 Acceptance of As-Built Plans

- 2.2.13.1 When the as-built plans and data are ready for approval and signing by the Engineering Manager, the DPA will submit them in the format described in Table 2-2.
- 2.2.13.2 The DPA is responsible for collecting and documenting information set out in the as-built plans. Disclaimers or endorsement negating responsibility will render the plans unacceptable and the 224 Certificate will be withheld. Further, if underground asset locations are found to be inaccurate on excavation or otherwise, the Developer may be liable for rectifying the situation.

2.2.14 Maintenance Certificate

- 2.2.14.1 On expiry of the 24-month maintenance period, the DPA will issue a maintenance certificate confirming that all outstanding maintenance has been completed.

2.2.14.2 The performance bond for maintenance will not be released by the Council until the work covered by the maintenance certificate is verified by the Council.

2.2.15 Phases and Information Requirements

Table 2-2 provides an outline of the information required at various phases of the approval process

Table 2-2 The Council's Requirements

Information/Data Required	Engineering Acceptance (Prior to construction)	Approval Phase	
		223 submission	224 submission
Design drawings /Plans	✓	✓ Amendments only	✗
Design specifications / Calculations	✓	✓ Amendments only	✗
Design Certificates / Reports	✓	✓ Amendments only	✗
Preliminary As-built Plans	✗	✓ Easement Layout only	✗
As-built Plans	✗	✗	✓
As-built coordinate and attribute data	✗	✗	✓
Construction certificates	✗	✗	✓
Operations and maintenance manuals	✗	✗	✓

2.3 Information and Data Requirements

Introduction

Accurate asset information is crucial to efficient and cost-effective operation, management, maintenance and knowledge of the Council's infrastructure assets. This section sets out the requirements for providing Design and As-built Plans, Information and Data.

Note:

"Tasman District Council is undertaking a review of its asset management data requirements. Once that review is completed a revised As-built Data Standard will be published separate from this Land Development Manual (LDM) and it will supersede the As-built requirements outlined in this manual. This manual will be amended to require Developers to comply with the newly published As-built Standard."

Mandatory Matters

2.3.1 General

- 2.3.1.1 The Council requires accurate and complete Design and As-Built information to be supplied for all infrastructural development or improvement works where:
- a) Infrastructure is intended to be transferred into the Council ownership;
 - b) Privately owned infrastructure is intended to be connected to the Council owned asset at the request of the Council;
 - c) Infrastructure is constructed as part of a capital works project or contract on behalf of the Council;
 - d) Infrastructure is upgraded or maintained on behalf of the Council through approved maintenance work.
- 2.3.1.2 Design and as-built information is required for all works relating to:
- a) Roading; including street lighting, road marking and signage
 - b) Rights-of-way;
 - c) Stormwater network infrastructure;
 - d) Wastewater network infrastructure
 - e) Watermains; and
 - f) Drains of 150mm equivalent diameter or greater
- 2.3.1.3 Design Information includes, but is not limited to:
- a) Design Drawings and Plans;
 - b) Design / Engineering specifications;
 - c) Design / Engineering calculations;
 - d) Certificates and reports.
- 2.3.1.4 As-built information Includes but is not limited to:
- a) As-built plans;
 - b) Coordinate data;
 - c) Asset attribute data;
 - d) Operation / Maintenance Manuals.

2.3.2 Media and Format

All plans, drawings and support information will be submitted in electronic format acceptable to the Council and in accordance with Table 2-3. Hardcopy plans, or data will not be accepted.

Table 2-3 Acceptable Format

Information Type	Acceptable Format (In preference order)
Design Drawing / Plan Specification	PDF
Design Specification	PDF Microsoft Excel Spreadsheet
Design/Engineering Calculation	PDF Microsoft Excel Spreadsheet
Operations and maintenance Manuals	PDF Microsoft Word Microsoft Excel
As-built Drawing /Plan	Single multi-page PDF
As-built Coordinate and Attribute data	Esri Shape file Microsoft Excel Spreadsheet Comma separated values (CSV) file Delimited Text file <i>DXF and DWG files may be accepted where provided in addition to the requirements above i.e. included with the PDF file and attribute data</i>

2.3.2.1 Hand drawn plans or plans with any hand drawn mark-ups or edits will not be accepted.

2.3.2.2 Plans will not contain any linked or embedded objects e.g. Excel spread sheets “copy and pasted” into the drawing file.

2.3.2.3 External referencing to image and other DWG files is acceptable as long as the referenced file is supplied with the data.

2.3.3 File Structure

2.3.3.1 Plans will be submitted as a complete set contained in a single file. (Multi-page PDF with a page per sheet).

2.3.3.2 Each service plan will be drawn as a separate sheet within the plan series i.e. a separate sheet for:

- a) Roading – including ROW, streetlights road marking and signage;
- b) Potable Water supply;
- c) Stormwater – including open drains of 150mm equivalent diameter or greater;
- d) Wastewater.

2.3.3.3 Sheets within a Plan will be numbered sequentially starting with sheet 1 and referencing the total number of sheets in the plan series e.g. “Sheet 1 of 10”.

2.3.3.4 Where more than five sheets are involved a title sheet will be included showing sheet numbers, individual sheet titles and site location plan.

2.3.3.5 A site location, in the form of a locality plan, including major street names and site identification will be shown.

2.3.3.6 As-built coordinate and attribute data must be provided at the same time the as built plans are submitted.

2.3.4 Layout

2.3.4.1 Plan layout will comply with AS1100.101 and have the following including title blocks to show:

- a) The project name;
- b) The appropriate resource consent number;
- c) The plan type and service/utility type e.g. 'AS-BUILT STORMWATER NETWORK';
- d) Plan numbering and revisions and date signed;
- e) Datum reference;
- f) North indicator;
- g) Scale and legend;
- h) Name of contractor and contact details.

2.3.5 Orientation of Plans and Sections

2.3.5.1 Plans will be orientated with either north or west to the top of the sheet. North point will always be shown.

2.3.5.2 In the case where a layout plan and longitudinal section appear on one sheet, the layout plan is to be orientated to suit the longitudinal section.

2.3.5.3 Plans and longitudinal sections will have the lowest distance on the left-hand side of the sheet. In drainage longitudinal sections, the lowest end of the drain will be at the lower distance and the plan should be orientated correspondingly.

2.3.5.4 Cross-sections of a street will commence at the bottom left hand corner of the sheet and proceed upwards where this is possible.

2.3.5.5 The symbols and arrangements will be as per AS1100.101.

2.3.5.6 Existing property boundary lines that abut the work and a north point will be shown as a reference.

2.3.5.7 Stormwater open channel cross-sections will be viewed looking downstream so that the true right bank is on the right-hand side.

2.3.6 Size and Scale

2.3.6.1 Plan scale will comply with AS1100.101.

2.3.6.2 Plans and drawings should preferably be produced at A3 paper size.

2.3.6.3 A1 plans may be accepted provided they can be reproduced at A3 paper size without loss of clarity or legibility. Where A1 plans cannot be reproduced at A3 without loss of clarity the Council may request a hardcopy version.

2.3.6.4 Text on an A1 full-sized plan reproduced on A3 will be a minimum of 1.25mm.

2.3.6.5 Text on plans will not obscure any line work.

2.3.7 Coordinate System, Datum and Accuracy

2.3.7.1 All plans will be provided in New Zealand GD 2000 Nelson Circuit or NZTM projection.

2.3.7.2 X and Y coordinates (Northing and Easting) will be recorded to two decimal places and accurate to ± 30 mm.

2.3.7.3 Vertical levels will be surveyed to New Zealand Vertical Datum 2016 (NZVD 2016) and recorded in metres. See Appendix E for Nelson and Tasman Vertical datum heights relative to NZVD 2016.

2.3.7.4 Vertical Accuracy (Z coordinates) will be recorded to two decimal places and accurate to ± 30 mm.

2.3.7.5 The map projection and Datum used must be stated on all plans.

2.3.7.6 The origin of levels will be recorded and accurate to two decimal places, for example "Origin of levels BP11 SO12345 = 4.26 NZVD2016.

2.4 Design Drawings

Mandatory Matters

2.4.1 General

2.4.1.1 Each and every plan must be signed by the Designer of the work. The Designer's signature is taken as evidence that the plans have been checked against and comply with the Nelson Tasman Land Development Manual. Unsigned plans will not be accepted.

2.4.1.2 For large subdivisions, full Design Drawings may be required by the Council prior to subdivision consent being granted.

2.4.1.3 The following plans and drawings of each street are required showing:

- a) Proposed and existing survey lots and Land Transfer (LT) numbers (if known);
- b) Street numbers;
- c) Names of new streets; and
- d) The location of services, including the necessary manholes, fittings and similar features (on separate plans for each service).

2.4.1.4 New services will be located as per AS1100.101, generally along with bench marks and survey mark levels.

2.4.1.5 The Designer will make every endeavour to locate existing power and telecommunication services.

2.4.1.6 Where proposed pipes cross under or over existing or proposed services, these services will be shown on the plan and section with reduced levels.

2.4.1.7 Plans will show the location of services in existing streets which abut the subdivisions.

2.4.1.8 A Traffic Management Plan is required by the Council for any work on or immediately adjacent to a public road for works that will or may pose a risk to road users. The Council requires demonstration

that the consent holder and agents are in compliance with requirements of the Health and Safety at Work Act 2015.

2.4.2 Earthworks Design Drawings

2.4.2.1 Earthworks drawings will be provided and must show:

- a) Original and finished contours;
- b) Proposed earthworks (cut and fill);
- c) Erosion and sedimentation control, including any staging;
- d) Geotechnical engineers input;
- e) Water bodies and drainage; and
- f) Property boundaries, kerb lines and street names.

2.4.2.2 A contour plan of the site at an appropriate interval in terms of the Council Datum NZVD2016 will be provided for all subdivisions and developments of 0.25 hectares or greater.

2.4.2.3 Data provided as a drawing file for the purposes of generating contour data, will be provided as 3D lines and 3D points to NZVD2016.

2.4.2.4 Erosion and sediment control must be shown in detail at the Engineering Drawing approval stage.

2.4.2.5 Information relating to contamination or potential contamination of the land will be submitted in accordance with National Environmental Standards for Contaminated Sites.

2.4.3 Road/Street Works Design Drawings

2.4.3.1 A road/street works plan will be provided and show:

- a) Property boundaries;
- b) Kerbs and channels;
- c) Road/street names;
- d) Footpaths;
- e) Longitudinal and cross sections of the existing ground;
- f) Proposed road/street levels with batters;
- g) Secondary flow paths and depth of ponding;
- h) Existing and proposed survey bench marks;
- i) Street trees and street gardens;
- j) Road marking; and
- k) Signs (where relevant).

2.4.3.2 Left-hand and right-hand top of kerb will be shown separately unless they are identical, in which case this will be stated.

2.4.3.3 The levels of the proposed services will also be shown on sections. Longitudinal sections will extend 40.0m beyond the extent of the works.

2.4.4 Wastewater Design Drawings

2.4.4.1 Wastewater services drawings will be provided and show:

- a) Wastewater pipes and manholes (in plan and long-section);
- b) Pipe size, length and gradient in long section;
- c) Pump stations;
- d) Stormwater pipes and manholes (for proximity purposes, with a thick line for wastewater and thin line for stormwater);
- e) Property boundaries, kerb lines and road/street names; and
- f) Wastewater discharge calculations complying with the NTLDM (please refer to Chapter 6 of the NTLDM).

2.4.5 Stormwater Design Drawings

2.4.5.1 Stormwater services drawings will be provided and show:

- a) Property boundaries;
- b) Waterways, streams, ponds, retention and detention devices, stormwater pipes, channels, subsoil drains, manholes and structures (in plan and long-section), pipe size, length and gradient in long section;
- c) Secondary flow paths, greenways and proposed easements;
- d) Wastewater pipes and manholes (for proximity purposes, with a thick line for stormwater and thin line for wastewater); and
- e) Property boundaries, kerb lines and road/street names.

2.4.5.2 Stormwater drawings submitted for checking will be accompanied by:

- a) Catchment plans showing all the catchment areas to be served; and
- b) Stormwater discharge calculations for each and every proposed pipe and channel.

2.4.6 Water Supply Design Drawings

2.4.6.1 Water supply services drawings will be provided and show:

- a) Water main and fittings;
- b) Pump stations, and
- c) Property boundaries, kerb lines and road/street names.

2.4.7 Street lighting, Power and Telecommunication Utilities Design Drawings

2.4.7.1 Street lighting, power and telecommunication utilities drawings will be provided and show:

- a) Cables ducts, boxes, pillars, cabinets and substations;
- b) Street lighting; and
- c) Property boundaries, kerb lines, vehicle and pedestrian entrances and road/street names.

2.4.7.2 Power, street lighting plans may be submitted separately to the Council as these are designed by specialists other than the DPA.

2.5 As-built Plans and Data

Mandatory Matters

2.5.1 General

- 2.5.1.1 As-built plans and all associated coordinate and attribute data must be submitted together as a single data package.
- 2.5.1.2 As-built plans will be signed and certified as correct and accurate by a licenced Cadastral surveyor or Chartered professional engineer
- 2.5.1.3 As-built plans will be provided and approved before the 223 certificate can be issued.
- 2.5.1.4 For the Council's physical works contracts, as-built drawings are required prior to issue of the Practical Completion certificate or within an agreed timeframe with the Engineering Manager's approval.
- 2.5.1.5 All non-standard structures (e.g. pump stations, reservoirs, bridges, and low impact stormwater devices) will be shown as an outline and all lids and surface openings will be shown and separately located. The position of all pipe connections to a structure will also be located with coordinates and invert.

2.5.2 As-built Quality

- 2.5.2.1 It is the responsibility of the parties providing as-built information to ensure the accuracy and quality of as-built information and to ensure compliance with the requirements in this document.
- 2.5.2.2 In the event of as-built data being incorrect the Council may decline to accept the application.
- 2.5.2.3 The Councils' receipt and acceptance of as-built information does not absolve those parties providing it of any responsibility for their accuracy or authenticity.
- 2.5.2.4 Where errors are found within the as-built information, the Council may require correction of those errors by the information provider.

2.5.3 As- built Coordinate and Attribute Data

- 2.5.3.1 The data supplied must be a complete and accurate representation of the assets, coordinates, levels and attributes shown on the associated as-built drawings.
- 2.5.3.2 A separate tabulation of all the point coordinates and levels specified in these standards will be shown on the drawing set as a cross-referenced table.
- 2.5.3.3 The file must be capable of being processed with one of the Council's current compatible systems and each point (coordinated location) will appear on a separate line.
- 2.5.3.4 Each point (excluding contouring spot heights) will be cross-referenced to a point on the as-built plans to clearly indicate the one that it represents.
- 2.5.3.5 The following format for each point (coordinated location) will apply:
 - a) Cross reference to location as shown on the plan;

- b) Easting;
- c) Northing;
- d) Level (0.0 if not supplied);
- e) Invert (0.0 if not supplied); and
- f) Description as applicable;
 e.g. for a simple text “comma” separated file:
- g) MH3a,2530000.58,5930000.64,14.53,10.25, Sewer Manhole;
- h) SMP3,2530010.63,5930005.62,15.98,10.25, Sump;
- i) MH4a,2530020.58,5930015.24,14.89,10.55,Sewer Manhole.

e.g. for a simple table or spread sheet file:

MH3a	2530000.58	5930000.64	14.53	10.25	Sewer Manhole
SMP3	2530010.63	5930005.62	15.98	10.25	Sump
MH4a	2530020.58	5930015.24	14.89	10.55	Sewer Manhole

2.5.4 Coordinate and Elevation Standards

2.5.4.1 Easting and Northing coordinates will be accurate to two decimal places and in terms of the following (in order of preference):

- a) New Zealand Transverse Mercator (NZTM);
- b) Local Circuit (NZGD) 2000;
- c) The local circuit origin will be stated on all plans;
- d) The map projection or coordinate system used must be stated on all plans;
- e) The origin of levels will be recorded to two decimal places, for example “Origin of levels BP11 SO12345 = 4.26 NZVD2016”;
- f) Known benchmarks and survey levels are recorded by the Council and are available from our regional GIS website Top of the South Maps www.topofthesouthmaps.co.nz or the LINZ website

2.5.5 Survey Datum

2.5.5.1 The levels shown on all plans must be surveyed to NZVD 2016.

2.5.5.2 The datum used must be stated on all plans.

2.5.6 Earthworks As-built Drawings

2.5.6.1 Where bulk earthworks have been carried out, sufficient additional levels, coordinates and break lines to regenerate contours on earthworks plans at 1.0m intervals will be provided. The contours are to be shown on an appropriate as-built plan.

2.5.6.2 Ground level in terms of the datum NZVD2016 will be shown on an appropriate plan at all boundary pegs for all subdivisions regardless of size.

2.5.6.3 Subsoil drains will be shown on as-built plans in terms of coordinates and invert level at all changes in direction and grade and inspection/monitoring points.

2.5.7 Road/Street Works As-built Drawings

2.5.7.1 In addition to the road/street works design drawing requirements, as-built plans will show:

- a) All kerbing (including traffic islands/traffic calming), channels where separate from kerb, or edge of seal or formed carriageway in the absence of kerbing;
- b) Points will be located at top of kerb, centre of channel or edge of seal and in terms of coordinates and level at changes of type, direction or grade;
- c) All curves are to be located using the tangent points and at least one central point on each curve;
- d) The location and width of footpaths. Locations in terms of coordinates are preferred but are acceptable in terms of offset from boundaries or kerb;
- e) The location of street trees and the area of street gardens. Locations in terms of coordinates are preferred but are acceptable in terms of offset from boundaries or kerb.

2.5.7.2 Road signs, including type, size, location and coordinates.

2.5.7.3 Road markings in terms of colour, width, symbol type or text and coordinates. Coordinates will be positioned at ends and changes of type and/or direction. All curves are to be positioned using the tangent points and at least one central point on each curve. Offsets from the front face of kerb and channel will be acceptable. Road marking symbols need only be positioned to their centres.

2.5.7.4 Bridge abutments, piers, carriageway, kerbing and footpaths in terms of outline coordinates and level, as per above specifications.

2.5.7.5 New or altered benchmarks and survey standards in terms of coordinates and level in terms of datum NZVD2016. The points will be clearly defined as either the Councils' bench mark (Council Ownership) or survey standard (LINZ ownership) and will be levelled/coordinated back to known benchmarks or reference points. The work must be undertaken in accordance with LINZ requirements.

2.5.7.6 Any road/street works removed or relocated will be noted on the plans to the same level of detail as new assets.

Note:

Further road construction information, such as the Road Assessment and Maintenance Management System (RAMM) data, as required on the standard form (see Chapter 4, Transportation, Appendix A) and the Streetlight Data Collection Form (see Chapter 9, Electrical and Streetlight, Appendix A) will be provided where applicable.

2.5.8 Wastewater As-built Drawings

2.5.8.1 In addition to the wastewater design drawing requirements, as-built plans will show:

- a) Material, class and size (diameter, or height and width) and date installed for all assets;
- b) Manholes, rodding points and formed bends in terms of coordinates, lid level, invert level and size and dimensions to lot boundaries where structures are not within a road or ROW pavement area;

- c) Pump stations, non-standard manholes, underground chambers, storage tanks, intake structures and outlet structures in terms of outline and pipe connection coordinates. Including invert levels on all chambers, storage tanks, wet wells, intakes and outlet points;
- d) Upstream and downstream invert levels on each length of pipeline. At drop manholes the invert is required for both the upper and the lower level entry point;
- e) Any change in direction, grade or type not located by the above information is to be defined in terms of coordinates and invert level;
- f) The blank end of pipe laterals or connection point to existing house drains. These will be in terms of coordinates and reduced level, depth to the blank end from the final ground level and distance from two readily defined permanent points (usually boundary pegs);
- g) Junction of laterals to mains in terms of coordinates or running distances along mains between surface features.

2.5.9 Stormwater As-built Drawings

2.5.9.1 In addition to the stormwater design drawing requirements, as-built plans will show:

- a) Material, class and size (diameter, or height and width) and date installed for all assets;
- b) Manholes, sumps and rodding points in terms of coordinates, lid level, invert level and size and dimensions to lot boundaries where structures are not within a road or row pavement area;
- c) Low impact or water sensitive design stormwater devices, including multi-functional greenways, detention basins, detention ponds, detention tanks, rain gardens, vegetated swales, soakage structures, filter strips, sand filters in terms of outline;
- d) Pump stations, non-standard manholes, underground chambers, storage tanks, intake structures and outlet structures in terms of outline and pipe connection coordinates. Including invert levels on all chambers, storage tanks, wet wells and intake and outlet points;
- e) Upstream and downstream invert levels of each length of pipeline (at node points). At drop manholes the invert is required for both the upper and the lower level entry point;
- f) Any change in direction, grade or type not located by the above information is to be defined in terms of coordinates and invert level;
- g) The blank end of pipe laterals or connection points to existing house drains in terms of depth to the blank end from the final ground level and measurements from two readily defined permanent points, usually boundary pegs, and as coordinates and reduced level;
- h) Junction of laterals to mains in terms of coordinates or running distances along mains between surface features.
- i) Subsoil drains in terms of coordinates and invert level at all changes in direction and grade and inspection/monitoring points;
- j) Watercourses, streams, rivers and secondary flow paths are to be defined by coordinates and levels at the centre line of water course and the top and bottom of both banks;
- k) Detention structures (inlet, outlet, spillway, dam crest) are to be specifically surveyed in terms of coordinates and level. Reservoir areas are to be defined by 0.2m contour data to maximum operating level.

- 2.5.9.2 An Operation and Maintenance Manual (electronic copy) is required for all detention dam structures. This manual will include key design parameters (such as reservoir catchment areas, inflows and reservoir and spillway operation) and ongoing maintenance and dam safety inspection requirements.
- 2.5.9.3 Operation and maintenance information may be required for non-standard stormwater components (such as water treatment devices, ponds, wetlands or swales). This information would include any special maintenance or servicing requirements.

2.5.10 Water As-built Drawings

- 2.5.10.1 In addition to the water supply design drawing requirements, as-built plans will show:
- Material, class, type and size (diameter, or height and width) and date installed for all assets;
 - Valves and hydrants in terms of coordinates and lid level size and dimensions to lot boundaries;
 - Meter boxes in terms of coordinates and lid level and by distance to two adjoining boundary pegs. In addition, the meter number and meter reading information is required. Refer to Chapter 7 - Water, Appendix A;
 - Ferrule connections in terms of coordinates;
 - Manholes in terms of coordinates, lid level size, invert level and dimensions to lot boundaries;
 - Water mains and rider mains, in terms of coordinates at any change in horizontal direction or material or type or diameter. Curves are to be located either using the tangent points and at least one central point on each curve or points at regular intervals;
 - Pump stations, storage tanks, reservoirs, chambers and non-standard manholes in terms of outline, pipe connection and lid coordinates, lid level and pipe connection inverts as well as floor and overflow levels;
 - Any horizontal change in direction or type not covered by the above information is to be defined in terms of coordinates. Curves are to be located using the tangent points and at least one central point on each curve. Offsets from the front face of kerb and channel may be acceptable;
 - Junctions of laterals to mains in terms of coordinates or running distances along mains between surface features.

2.5.11 Pump Stations and other Electrical Equipment

- 2.5.11.1 Details of any reservoir, pump, motor components, automated valve and electrical control equipment will be incorporated in a manual for the site, which is to include all manufacturer supplied data for equipment used, wiring diagrams, control programs and any other relevant data for the site such as pipework placement diagrams, operational schematic diagrams and site drawings.
- 2.5.11.2 The manual will also include a summary of services provided to the site and the term and conditions for each service e.g. electricity supply. Where these services have been obtained by the Council, the provision of such data will be the responsibility of the respective Councils.

The master manual is to be provided in electronic form as per Table 2-3.

2.6 Other Utilities

- 2.6.1.1 Electrical, telephone and other reticulation drawings will be supplied to the relevant network line operator(s). The Council may require evidence from the relevant network line operators that the as-built plans have been received and are fit-for-purpose.
- 2.6.1.2 The Council will require an as-built plan of all road/streetlights installed and completion of the data collection form (see Chapter 9, Appendix A) which will include:
- a) Location in terms of coordinates;
 - b) Light type, dimensions, wattage and date installed.
- 2.6.1.3 In addition to new assets, as-built information will show all existing assets that have been made redundant. The assets will be marked as either “abandoned” or “removed”. Where an existing pipe or asset has been made partially redundant the coordinates and invert of the disconnection point are required.
- 2.6.1.4 The location and level of all existing drainage and water services encountered during construction will be verified and recorded on as-built plans.
- 2.6.1.5 As a minimum, at least one asset feature (such as a manhole lid and invert, valve or hydrant lid) adjacent to each new service will be surveyed and recorded on the as-built plans.

Appendix A Engineering Design Drawing and As-built Drawing Approval Process

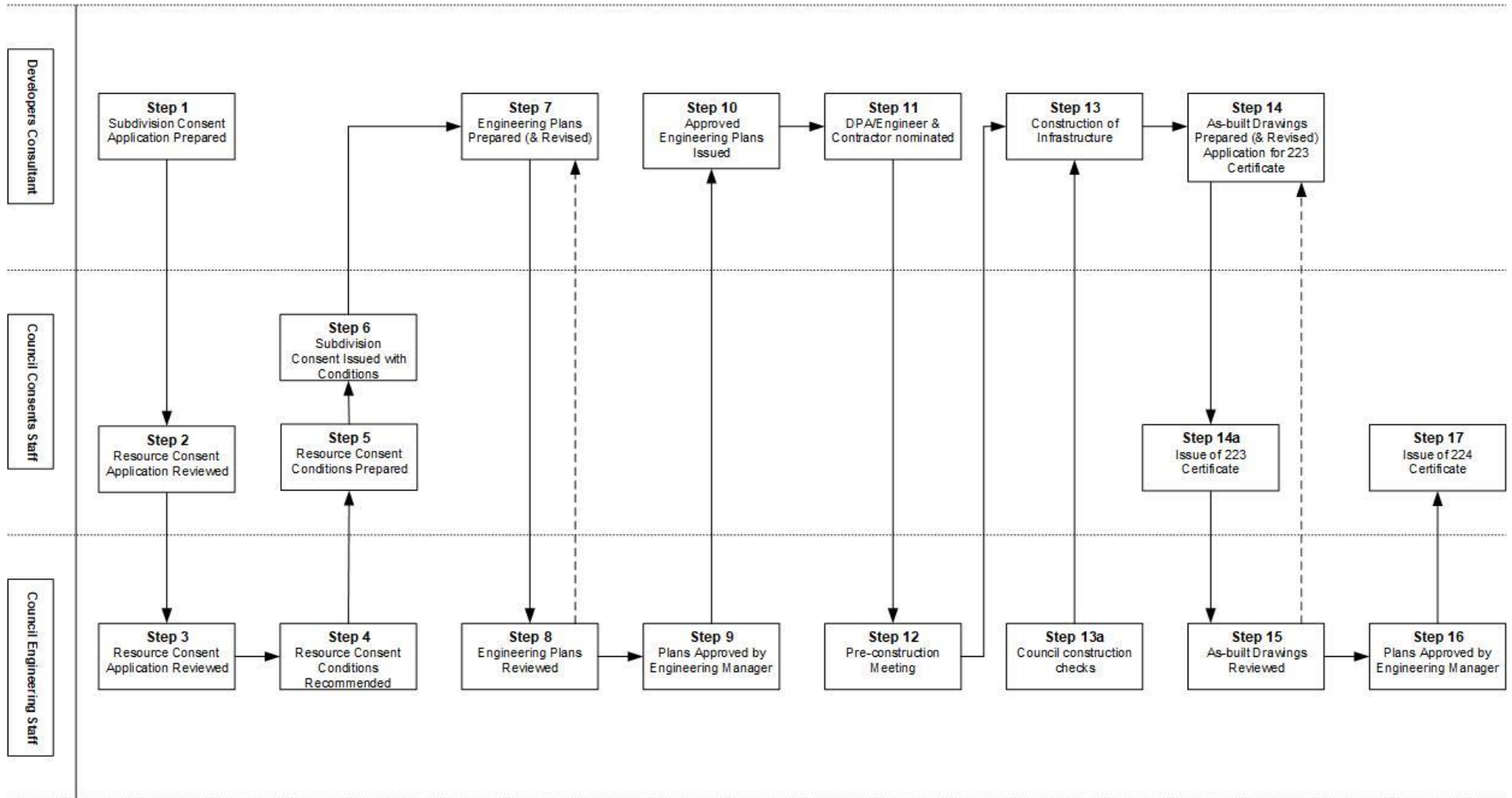

All changes to this procedure must be agreed by the Engineering Manager and must be notified to the Council's consent team.

Appendix B Design Certificate – Land Development/Subdivision Work

ISSUED BY: _____
 (Approved certifier)

TO: _____
 (Developer/Owner)

TO BE SUPPLIED TO: _____
 (Territorial authority)

IN RESPECT OF: _____
 (Description of land development/subdivision work)

AT: _____
 (Address)

has been engaged by _____
 (Consultant/Designer) (Developer/Owner)

to provide _____ services in respect of the land development and/or
 subdivision work described above.

I _____ have the qualifications and experience relevant to this project as set
 out herein and have designed the subject works and confirm that the design is to current good engineering
 practice, and that it satisfies all relevant resource consent conditions, all relevant Council requirements and
 applicable codes and standards.

I/My practice holds professional indemnity insurance in the sum of \$ _____ and run-off cover.

(Signature of approved certifier) _____ Date _____

 (Professional Qualifications) RPSurv CPEng

 (Address) Practice field
 Civil Mechanical
 Structural Electrical
 Geotechnical Industrial
 Environmental

Outstanding Works _____

Appendix C Designer's Check Sheet

Councils' Consent No: _____

Date: _____

Site Address:		
Site Legal Description:		
Designer:	Name	
	Address	
Qualification:	Phone No:	
	Fax No:	
Engineer/Surveyor Contact:		
Landowner:	Name:	
	Address:	
	Phone No:	

Place a tick in a box if information is provided, otherwise write NA for not applicable

Reason for Submission: Subdivision R.O.W

Development Other

Design Certificate provided

Drawing Sheet size and number of sheets A3 A2

Drawing to AS 1100.101 and LDM Section 2.2.15.

Levels to NZVD2016 Locality Diagram

Contour Plan Spot Levels

Overall Site Plan

Plans and Sections Road/street works Power

Drainage Telecommunications

Water Earthworks

Sewerage Catchment Plans and Discharge Calculations

Stormwater Catchment Plans and Discharge Calculations

Road/Streetworks Pavement Design

Specific Design – specify aspect:

Owner's Consent for Work in Private Property

Appendix D Certification upon completion of Subdivision Work

ISSUED BY: _____
 (Approved certifier)

TO: _____
 (Developer/Owner)

TO BE SUPPLIED TO: _____
 (Territorial authority)

IN RESPECT OF: _____
 (Description of land development/subdivision work)

AT: _____
 (Address)

 (Consultant/Designer) (Developer/Owner)

to provide construction observation, review and certification services in respect of the above subdivisional work which is shown on the drawings numbered _____

Approved by _____
 (Territorial Authority)

I have sighted the _____ consent and conditions of consent to the
 (Territorial Authority)
 subdivisional works and the approved drawings.

"I believe on reasonable grounds that the works other than those outstanding works listed below, are complete and have been constructed in accordance with:

- a) The approved engineering drawings and any approved amendments, or as modified by d) below; and
- b) The Council's Land Development Manual; and
- c) Manufacturer's Instructions; and
- d) The resource consent conditions

_____ Date _____

 (Professional Qualifications)

RPSurv CPEng

Practice field

(Address) _____

Civil Mechanical

Structural Electrical

Geotechnical Industrial

Environmental

Outstanding Works:

Appendix E Nelson and Tasman Vertical Datum's

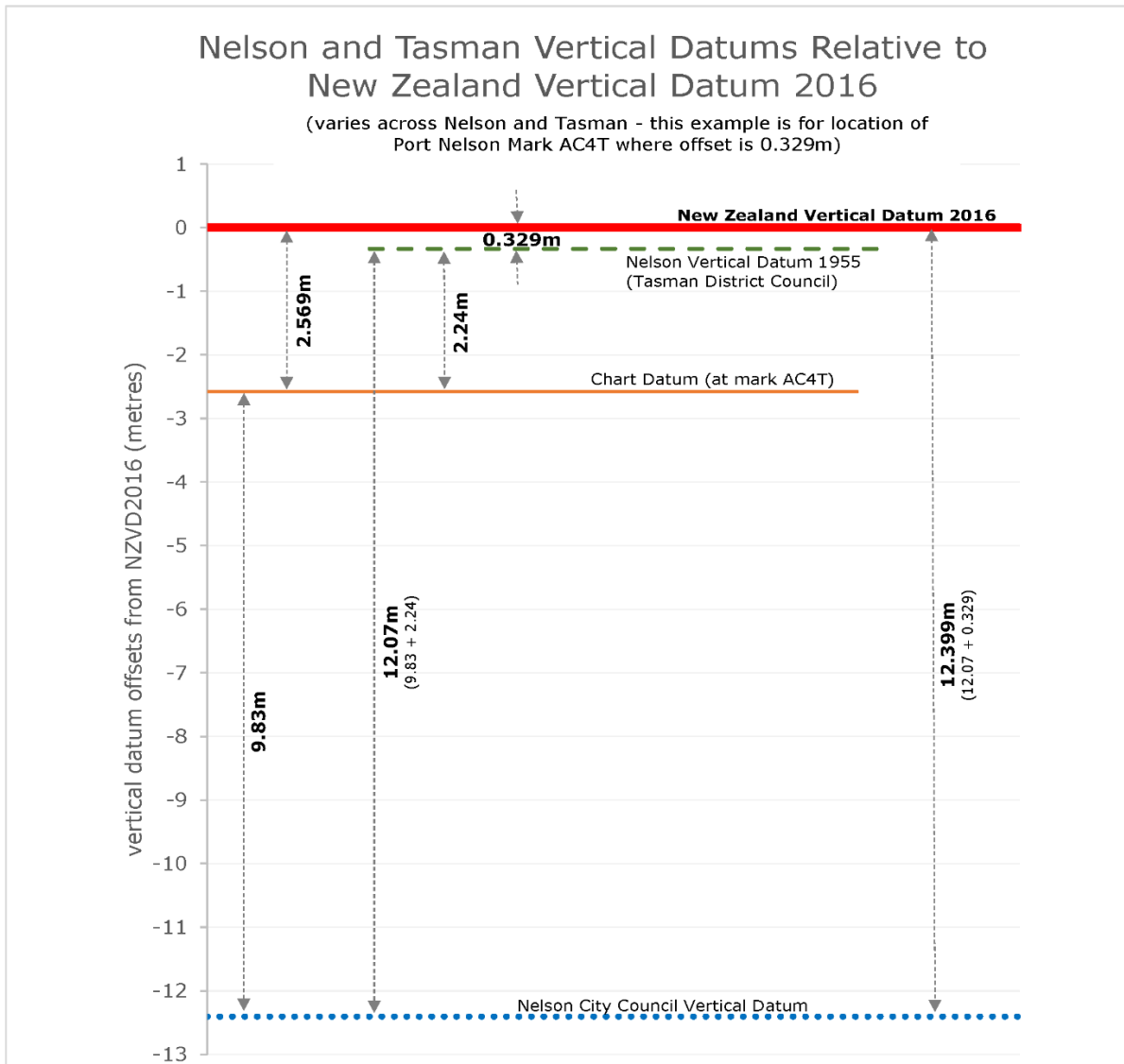

STANDARD SYMBOLS

<u>SURVEY LINES</u>		LINEWEIGHT 0.25mm
<u>LAND BOUNDARIES</u>		CIRCLE DIA 2mm LINEWEIGHT 0.25mm
<u>NEW WATERMAINS (BLUE)</u>		LINEWEIGHT 0.50mm
<u>EXISTING WATERMAINS</u>		LINEWEIGHT 0.35mm
<u>HYDRANTS</u>		PIPE DIAMETER AT PERIODIC INTERVALS ALONG THE LINE DIA 2mm
<u>VALVES & METERS</u>		LINEWEIGHT 0.50mm
<u>NEW SEWER (RED)</u>		LINE LENGTH 20mm LINE GAP 10mm
<u>EXISTING GRAVITY</u>		LINEWEIGHT 0.35/0.5mm
<u>EX. SWALLOWS OR PRESSURE</u>		DIA'S 2&3mm
<u>EX. RISING OR PUMPING</u>		LINEWEIGHT 0.35/0.5mm
<u>EX. MANHOLE</u>		DIA'S 2&3mm
<u>NEW STORMWATER (GREEN)</u>		LINEWEIGHT 0.50mm
<u>EXISTING MAIN</u>		LINEWEIGHT 0.35/0.5mm
<u>EX. MANHOLE</u>		DIA'S 2&3mm
<u>OPEN DRAINS</u>		LINEWEIGHT 0.25mm
<u>CABLES</u>		
<u>TELEPHONE</u>		LINEWEIGHT 0.35/0.5mm DIA 2mm
<u>ELECTRICITY</u>		LINEWEIGHT 0.25mm DIA 2mm
<u>KERB & CHANNEL</u>		LINEWEIGHT 0.5mm
<u>SUMPS</u>		
<u>RETAINING WALLS</u>		LINEWEIGHT 0.25mm
	ANNOTATED e.g CRIBWALL	

PROVIDE SPACE ON TITLE FOR TYPICAL SIGNATURE
BLOCK MEASURING 100mmX25mm

(HEIGHT of 25mm)	(WIDTH of 100mm)	PLAN No.
		RESOURCE CONSENT No.

SITE CONTOURS 1:1000 1:500 1:250 1:200
STREETS KERB & CHANNEL AND FOOTPATHS
 PLAN 1:500 1:250 1:200
 LONGITUDINAL SECTION :
 HORIZONTAL 1:500 1:250 1:200
 VERTICAL 1:50 1:25 1:20

SOIL & STORMWATER SEWERS
 PLAN 1:500 1:250 1:200
 LONGITUDINAL SECTION :
 HORIZONTAL 1:500 1:250 1:200
 VERTICAL 1:50 1:100
 DETAILS 1:20 1:10 1:5

CROSS SECTIONS
 HORIZONTAL 1:50
 VERTICAL 1:100 1:50 1:20
 ANY VARIATION FROM THESE SCALES AS SHOWN SHALL HAVE THE PRIOR APPROVAL OF THE COUNCIL
 SHEET SIZES: A1 594mm x 841mm
 A2 420mm x 594mm

SERVICES GENERAL
 PLAN 1:500 1:250 1:200
 CROSS SECTIONS 1:50
 MAIN SHEETS REQUIRED:
 1. ROADING
 2. SEWERS-STORMWATER-KERBS
 3. WATER-TELEPHONE-POWER-KERBS

ALL INKS AND LETTERING USED SHOULD BE SUITABLE FOR SCANNING REPRODUCTION.

NELSON CITY COUNCIL GROUP MANAGER INFRASTRUCTURE, NELSON	DRAWING SYMBOLS & SCALES		
TASMAN DISTRICT COUNCIL ENGINEERING SERVICES MANAGER, TASMAN	DATE 01/07/19	NELSON - TASMAN LAND DEVELOPMENT MANUAL	201

LONGITUDINAL SECTION

ROADS

HEIGHT ABOVE NZVD 2016

OTHER LEVELS (E.G. EXISTING SERVICES)	
TOP OF KERB LEVEL R.H. SIDE	
TOP OF KERB LEVEL L.H. SIDE	
GROUND LEVEL PEG LEVEL	
HORIZONTAL DISTANCE	
GRADIENT R.H SIDE (% OR 1 IN ...)	← V.C. →
GRADIENT L.H SIDE	
HORIZONTAL CURVE	← H.C. → %S.E.

SEWER & STORMWATER

HEIGHT ABOVE NZVD 2016

OTHER LEVELS (E.G. SERVICES CROSSING THE LINE)	
HYDRAULIC GRADE LEVEL (IF APPLICABLE)	
GROUND LEVEL PEG LEVEL	
CUT (GROUND LEVEL TO INVERT)	
SEWER INVERT	
SEWER DISTANCE (TRUE HORIZONTAL DISTANCE ALONG SEWER)	
GRADIENT (% OR 1 IN ...)	
DIAMETER (MILLIMETERS INTERNAL) & PIPE TYPE/MATERIAL	

NOTES

1. ALL LEVELS IN TERMS OF HEIGHT ABOVE NZVD 2016 DATUM IN METRES
2. ALL DISTANCES IN METRES.
3. GROUND OR PEG LEVELS SHOWN ON SECTIONS ARE TO BE THOSE ON THE LINE OF THE SEWER
4. PIPELINES DESIGNED TO OPERATE UNDER PRESSURE SHALL INCLUDE THE HYDRAULIC GRADE LINE, ITS LEVELS AND GRADIENTS.
5. BLOCKS MAYBE EXTENDED TO ALLOW "AS BUILT" DATA TO BE ADDED.
e.g: AS BUILT SEWER INVERT
AS BUILT DISTANCE
AS BUILT GRADIENT
6. LOWEST LEVEL ON LONGITUDINAL SECTION ON LHS

COLOUR CODE

COLOUR CODE PRIMARILY FOR USE ON WHITE PAPER. ALL INKS USED SHOULD BE SUITABLE FOR DYELINE PHOTOCOPYING AND REPRODUCTION.

SYMBOL IS FOR WHEN COLOURS ARE TO BE REPRODUCED IN BLACK

COLOUR CODE FOR EARTHWORKS IN SECTION

FILLING	GREEN	SYMBOL =	
CUTTING	RED	SYMBOL =	
REPLACEMENT GRAVEL	BROWN	SYMBOL =	
BASECOURSE	BLUE	SYMBOL =	
EARTH (TOPSOIL)		SYMBOL =	

<p>NELSON CITY COUNCIL</p> <p>GROUP MANAGER INFRASTRUCTURE, NELSON</p>	<h2 style="margin: 0;">DRAWING STANDARDS & SYMBOLS</h2>		
<p>TASMAN DISTRICT COUNCIL</p> <p>ENGINEERING SERVICES MANAGER, TASMAN</p>	<p>DATE</p> <p>01/07/19</p>	<p>NELSON - TASMAN LAND DEVELOPMENT MANUAL</p>	<h1 style="margin: 0;">202</h1>



Chapter 3

Definitions

CHAPTER 3 DEFINITIONS

The following words and their meanings are provided as definitions of terms used in all Chapters of the Nelson Tasman Land Development Manual (NTLDM).

Accessway – means a corridor with a path for mobility scooters, pedestrians and cyclists linking between road to road or road to public places.

All Weather Surface – means construction of a carriageway with adequate drainage, a sound subgrade, dust free and compacted graded aggregates that results in a carriageway that is usable by vehicles in all weather conditions.

Annual Exceedance Probability (AEP) – means the probability of exceedance in any 12-month period.

CE's – means Cleaning Eyes/Inspection Point.

Classified Roads – means roads with a hierarchical classification of Arterial, Principal and Collector. Sub-Collector Roads, Local Roads and Residential Lanes are grouped and termed *Unclassified Roads*. A description of each type of road is located in section 4.4.1 Road Hierarchy.

Connection Point – means the point where customer's equipment or cabling connects to a Network Operator's reticulation. This point is the demarcation point between the Network Operator's reticulation and customer-owned cables (usually referred to as ETP, (External Termination Point)). Road reserve has the same meaning given to it by section 315 of the Local Government Act 1974.

Consent Notice – means a form of covenant between the Council and a land owner and can only be imposed through a subdivision consent. A consent notice will be registered on the title of a property, alerting current and future property owners of certain obligations that must be complied with on a continuing basis by the owner, and subsequent owners, of a title. Because a consent notice is an agreement between the Council and the land owner, it is the Council which will enforce any non-compliance.

Council – means either the Nelson City Council or the Tasman District Council and includes the respective councils' officers.

Cul-de-sac – means a 'no exit' street. The extent of a cul-de-sac is defined from the last intersection that provides driver choice to multiple destinations within the wider transport network i.e. a through road.

Cycleway – means so much of any road (or other land) as is laid out or constructed by authority of the territorial authority primarily for cycles; and may include the edging, kerbing and channelling thereof.

Designer – means the person responsible for producing or submitting the Engineering Drawings for approval and may be a Chartered Professional Engineer, Registered Professional Surveyor or authorised person experienced in the production, design and submission of plans.

Developer – means an individual or organisation having the financial responsibility for the development project and includes the owner.

Developer's Professional Advisor (DPA) – means the person, appointed by the developer being a Registered Professional Surveyor or a Chartered Professional engineer, who shall be responsible for:

- a) The investigation, design and obtaining of approvals for the works;
- b) Contract administration and oversight of the works;
- c) Certification upon completion of the works; and
- d) Sole point of communication with Council.

Developers Professional Advisor's Representative (DPAR) – means the person who has the delegated authority to represent the DPA. The DPA may nominate in writing to the Council Engineering Manager a DPA Representative for the construction phase of the project. The DPA's Representative must be a suitably qualified and competent person and not be a body corporate or firm. The Council will not unreasonably withhold the nomination of the DPA's Representative. References in this document to DPA also apply to the DPAR.

DI – ductile iron pipes; means iron pipes generally socket jointed with Tyton elastometric seal rings.

DN – means nominal pipe bore diameter in millimetres. For polyethylene pipes, this relates to the pipes' outside diameter. For other pipes this relates to the internal diameter.

Domestic Driveway – means any vehicular path providing access to one residential unit.

DP (Design Pressure) – means the maximum operating pressure that the designer expects to act on the pipeline in service.

Drainage – means wastewater drainage or stormwater drainage, and “drain” has a corresponding meaning.

Dwelling – is the meaning given in the Tasman Resource Management Plan, or meaning given for *residential unit* in the Nelson Resource Management Plan.

Easement in Gross – means an easement that does not attach to any dominant tenement; and includes the right of public utilities, such as power, gas, phone, water and sewerage, to use part of the land. An easement in gross remains forever on the certificate of title irrespective of ownership changes or subdivision.

Earthworks – is the meaning given in the relevant Resource Management Plan (RMA).

Electricity (Network) Operator – means any person (company) declared (by the Minister) under section 4 or section 4a of the Electricity Act 1992 to be an Electricity Operator. A list of current Electricity Operators is held by the Ministry of Economic Development and is available on their website.

Electrical Reticulation – means all electric lines that are owned by the line owner and form part of the line owner's electrical reticulation system or network.

Engineering Manager – means the Nelson City Council Group Manager Infrastructure or the Tasman District Council Engineering Services Manager or their delegates.

Exclusive Fittings – means those fittings used or intended to be used for the purpose of supplying electricity exclusively to that property.

Floodway – means part of a greenway that caters for the design flood (normally a 1% AEP event) and includes allowance for mature riparian vegetation within flood flow capacity.

Footpath – means so much of any road as is laid out or constructed by authority of the territorial authority primarily for pedestrians; and may include the edging, kerbing and channelling thereof.

Geotechnical Engineer – means a Chartered Professional Engineer (CPEng) or an Engineering Geologist with recognised qualifications and experience in geotechnical engineering and experience related to the development.

Greenway – means a multi-functional, integrated green space used to protect natural waterways and stormwater flow paths, and which accommodates primary and secondary stormwater flows, stormwater management features and open space, amenity and ecological values. Greenways may be made up of a mixture of reserve types including local purpose reserves, and may enhance local open space and transport networks by linking with other local reserves and walkways.

Ground – means the material in the vicinity of the surface of the earth whether soil or rock.

GRP – means glass reinforced plastic pipes, for example; Hobas. This type of pipe is generally only used for major transfer or transmission mains since pipe diameters of less than DN 300mm are rare.

Hillside Environment – means ground where development occurs on an average slope of greater than 10 degrees.

HCV – means a Heavy Commercial Vehicle.

Independent Qualified Person (IQP) – means a specialist approved by the territorial authority and having the appropriate skills and qualification to carry out specific procedures.

Installation – includes excavation, the laying or thrusting of the pipe, ducting or cabling service, backfilling and reinstatement of surface.

Land Drainage System – means the network flow of surface water and groundwater and includes peak surface discharges and their regulation under urban conditions.

Landowner – means the consent holder or persons responsible for, or authorised persons subdividing or developing the land.

LGA – means the Local Government Act 2002.

LGOIMA – means the Local Government Official Information and Meetings Act 1987.

Line Owner – means a person or company that owns electrical reticulation (works) that are used or intended to be used for the conveyance of electricity.

LINZ – means Land Information New Zealand.

Low Impact Design – is the meaning given in the relevant Resource Management Plan.

LTP – means the relevant Long-Term Plan.

Manager – means the Group Manager Infrastructure (Nelson City Council) or the Engineering Services Manager (Tasman District Council) or their delegates.

Maximum Design Pressure (MDP) – the maximum instantaneous pressure that may be created within a pipeline, including for pressure surge effects.

Means of Compliance – means a method by which the requirements of the standard may be complied with. It implies that there may be other methods which may meet the requirement subject to specific consideration or approval.

Median – means a raised traffic island which is a useful traffic management device to channel traffic or provide a refuge for pedestrians crossing the road. Flush medians are most commonly used on 'Classified Roads' where property access needs to be maintained but where there are safety benefits in removing turning vehicles from the through traffic stream, and in providing pedestrians with an opportunity to cross the road in two stages.

MHWS – means Mean High Water Springs.

Network Connection Point – means the position where a service connects to a Line Owner's network.

Network Operator – means any person (company) declared (by the Minister) under section 102-105 of the Telecommunications Act 2001 to be a Network Operator. A list of current Network Operators is held by the Ministry of Economic Development and is available on their website.

Network Owner – means any person or Company that owns Works (telecommunication reticulation) that are used or intended to be used for the conveyance of telecommunication.

Network Utility Operator – has the same meaning given to it by Section 166 of the Resource Management Act 1991.

Nominal Pressure Rating (PN) – the pressure marked on the pipe or component and the maximum pressure that it can operate at throughout its design life.

NRMP – the Nelson Resource Management Plan (reference is also made to the **TRMP** meaning the Tasman Resource Management Plan. The location of the development will dictate the applicable Plan).

NTLDM – means the Nelson Tasman Land Development Manual.

NZTA – the New Zealand Transport Agency.

NZVD2016 – means New Zealand Vertical Datum 2016.

ONRC – means One Road Network Classification, and is a nationally consistent road hierarchy classification system that is used in transport activity management that puts the current users at the heart of every investment decision. Refer to the NZTA [general guide](#) for further details.

Operating Pressure – means the internal pressure which occurs at a particular time and that on average will likely be experienced at a particular point in a water reticulation system on a typical day. For a gravity system, the operating pressure will depend on the water level of the reservoir, the ground level at the point on the pipeline under consideration, and the head loss due to demand in the system.

Operator – shall mean the party or parties either as approved by the Council or as approved as a network operator under the Telecommunications Act 2001 or as approved under any other service supply Act to carry out excavation, backfilling or reinstatement works within the road reserve under the control of the Council.

Owner – the owner of the land that has the power to make decisions about the land and the power to sell the land. Includes the Crown, the Public Trustee, and any person, local authority, board, or other body or authority however designated, constituted or appointed.

PE – polyethylene, generally pipes for water supply networks, for example PE 80B or PE 100. PE 80C is not recommended for long-term water reticulation networks.

Permanent Surface – means an impermeable sealed surface such as concrete or asphaltic concrete.

PN8 – indicates the nominal pressure rating of the pipe (the higher the number the higher the strength and quality).

Point of supply – means the point at which the line owner responsibility ends has the meaning as per the Electricity Act 1992 section 2.

Potential development - means the likely future development within the Services Overlay taking into account Structure Plans, Indicative Roads, any Council Development Plans, and the LTP.

Primary Design Flow – is the estimated run-off selected to provide a reasonable degree of protection to the surrounding land and buildings. In most cases this flow will be piped or contained within relatively narrow confines under public control by reserve or easement.

Private - drain serving one property,

Private/Common - drain serving two to five properties,

Private Road – means any roadway, place or arcade laid out within a district on private land by the owner thereof intended for the use of the public generally.

Private ways – means privately owned and used rights of way, access lots and private driveways, and are for the purpose of access over private land to private property.

PVC – (Polyvinyl Chloride), material from which the pipe or fitting is produced; has a similar meaning for uPVC, mPVC and PVC-O.

Reserves Manager – means the Reserves and Facilities Manager of the Tasman District Council or and the Manager Parks and Facilities (Nelson City Council) or their delegates.

Residential Dwelling - means the same as Residential Unit

Residential Unit means a ‘dwelling’ in the Tasman District or in Nelson City, a single self-contained household unit, used principally for residential activities, whether by one or more persons, including accessory buildings. Where more than one kitchen facility is provided on the site, there shall be deemed to be more than one residential unit.

RMA – means the Resource Management Act 1991.

Road – has the same meaning given to it by section 315 of the Local Government Act 1974.

Road Reserve – means the whole parcel(s) of land designated as road reserve.

ROW – means Right-of-Way as defined by section 348 of the Local Government Act 1974.

Runoff cover – means extension of insurance cover if a company ceases trading.

SD – refers to a Council Standard Drawing detail.

Secondary Flow Path – refers to the path taken by run-off in excess of the primary design flow.

Service or Service Main – is the term for the cable (fitting), owned by the owner of premises and connecting premises to the electrical reticulation at an agreed network connection point.

Speed Environment – For existing roads, the speed environment is 85th percentile of recorded driver speed. For new roads, the speed environment is target speed as defined in Section 4.5.1.

STP – means System Test Pressure.

Stormwater – is the meaning given in the relevant Resource Management Plan.

Street – has the same meaning as “road” as defined by section 315 of the local Government Act 1974.

Survey Plan – means a survey plan in terms of section 2 of the Resource Management Act 1991.

Swale – means a constructed watercourse shaped or graded in earth materials and stabilised with site-suitable vegetation, for the safe conveyance and water quality improvement of storm run-off.

System Test Pressure (STP) – the hydrostatic pressure to be applied to a newly laid pipeline (measured at the lowest point) to ensure its integrity and water tightness.

Telecommunications – means any telecommunications infrastructure, line or wireless facility.

Telecommunications Network – means information communications technology infrastructure associated with the delivery of telecommunications technology comprising one or a combination of the following:

- a) Connections over fibre optic lines;
- b) Connections over copper wire;
- c) Structures providing wireless or satellite or antenna connections;
- d) Conduits, masts and pre-cast pits to accommodate all of the above.

Telecommunications Reticulation – means all cables/lines that are owned by the Network Operator and form part of the Network Operators Reticulation System or “Network”.

Territorial Authority (TA) – means a territorial authority as defined in the Local Government Act 2002.

TMP – means Traffic Management Plan.

TRMP– the Tasman Resource Management Plan (reference is also made to the **NRMP** meaning the Nelson Resource Management Plan). The location of the development will dictate the applicable Plan.

Unclassified Roads – roads with a hierarchical classification of Sub-Collector Roads, Local Roads and Residential Lanes. Arterial, Principal and Collector roads are grouped and termed **Classified Roads**.

Urban Design – is the meaning given in the Resource Management Plan.

Urban Drainage Area – means a drainage area as identified by Council.

Vehicle Access Point – is the point where a domestic driveway or access driveway connects to the formed carriageway of a road.

Vehicle Oriented Commercial Activities – includes service stations, truckstops, supermarkets, shopping malls and drive-in or drive-through retail outlets.

Wastewater – is water that has been used and contains unwanted dissolved and/or suspended substances from communities, including homes, businesses and industries.

Water Sensitive Design – means the management of freshwater that protects and enhances the values and functions of natural ecosystems, addresses stormwater effects as close to source as possible and mimics natural systems and processes for stormwater management.

Water Supply Authority (WSA) – is the operational unit of the Territorial Authority responsible for the supply of water, including its authorised agents.

Works – means any type of construction or infrastructure and includes earthworks. Works can also be in the form of “money” as defined by the RMA.

Zone Terminology

The following table provides definition and clarification of the specific zones that form the definition of the generic terms listed below:

NTLDM generic zone reference	Specific Zones that form the definition	
Zone reference	TRMP	NRMP
Residential	Residential Papakainga	Residential Residential HD Residential LD Residential LD Stoke
Rural Lifestyle	Rural Residential Rural 3	Rural HD small-holdings Rural LD small-holdings
Rural	Rural 1 Rural 2	Rural
Commercial	Commercial Mixed-Business Central-Business Tourist Services	Inner City Fringe Inner City Centre Suburban Commercial

NTLDM generic zone reference	Specific Zones that form the definition	
Industrial	Rural Industrial Light Industrial Heavy Industrial	Industrial Industrial Nayland Road South
Open Space	Open Space Conservation Recreation	Conservation Open Space



Chapter 4

Transportation

TABLE OF CONTENTS

CHAPTER 4	TRANSPORTATION.....	1
INTRODUCTION		1
4	PURPOSE.....	1
4.1	Performance Outcomes	1
4.1.1	Performance Outcomes - Detail	2
4.1.2	Creating Good Infrastructure – Design-Led Approach.....	2
4.2	Referenced Documents.....	3
4.2.1	Resource Management Plan Requirements	3
4.2.2	Document and Standards.....	3
4.2.3	Transport Network	5
STANDARDS		5
4.3	Design Process	5
	Mandatory Matters	5
4.3.1	General	5
	Good Practice	7
4.3.2	General	7
4.4	Network Layout Form and Function Design	7
	Mandatory Matters	7
4.4.1	Road Hierarchy.....	7
4.4.2	Design within the Hierarchy.....	10
4.4.3	Minimum Intersection Spacing	11
4.4.4	Connectivity	12
4.4.5	Pedestrian, Cyclist and Public Transportation.....	14
4.4.6	Structures	14
4.4.7	Commercial Zone Design	14
	Good Practice	15
4.4.8	Layout.....	15
4.4.9	Pedestrian, Cyclist and Public Transport Considerations	15
4.4.10	Intersections	16
4.4.11	Design for Larger Vehicles	16
4.4.12	Use of Residential Lanes.....	17
4.5	Design for the Speed Environment.....	17
	Mandatory Matters	17
4.5.1	Design for Target Speed	17
4.5.2	Traffic Calming Devices.....	18
	Good Practice	18
4.5.3	Speed Environment.....	18
4.5.4	Speed Reduction Measures	19
4.6	Transport Cross-Sections.....	20
	Mandatory Matters	20
4.6.1	General	20
4.6.2	Shoulder Design	23
4.6.3	Flush Medians	23

4.6.4	Turning Area Design.....	23
4.6.5	Staged Road Construction Ends	24
4.6.6	Service Lanes	24
4.6.7	Services	24
	Good Practice	25
4.6.8	General	25
4.6.9	Legal Road Widths	25
4.6.10	Flush Medians	26
4.6.11	Turning Areas	26
4.6.12	Shoulders.....	26
4.7	Batter Slope, Bridge and Retaining Structure Design	26
	Mandatory Requirements.....	26
4.7.1	Batter Slope	26
4.7.2	Support and Retaining Structures and Bridges	27
4.7.3	Geotechnical Risk Areas	28
4.7.4	Sub-soil Drainage	28
	Good Practice	28
4.7.5	Hillside Construction.....	28
4.7.6	Land Stability	28
4.7.7	Retaining Walls.....	29
4.8	Road Geometry	29
	Mandatory Requirements.....	29
4.8.1	Gradients	29
4.8.2	Crossfall.....	30
4.8.3	Super Elevation	30
4.8.4	Horizontal curves.....	30
4.8.5	Safe Stopping Sight Distances	31
	Good Practice	33
4.8.6	Gradients	33
4.8.7	Super-Elevation	33
4.8.8	Kerb Lines.....	33
4.9	Intersection Design.....	33
	Mandatory Requirements.....	33
4.9.1	General	33
4.9.2	Sight Distances.....	34
4.9.3	Kerb Radii.....	35
	Good Practice	36
4.9.4	General	36
4.9.5	Four Way Intersections.....	36
4.9.6	Roundabouts	36
4.9.7	Traffic Signals.....	37
4.10	Private Access and Crossings	37
	Mandatory Requirements.....	37
4.10.1	General	38
4.10.2	Private Access	38
4.10.3	Gradients	41
4.10.4	Sight Distances (other than Safe Intersection Site Distance)	41
4.10.5	Visibility Splays	42
4.10.6	Tracking Paths.....	43

4.10.7	Minimum distance of a vehicle crossing from intersections	44
	Good Practice	45
4.11	Clear Zones.....	46
	Mandatory Requirements.....	46
4.11.1	General	46
	Good Practice	47
4.11.2	General	47
4.12	Parking (on street/road)	47
	Mandatory Requirements.....	47
4.12.1	General	47
	Good Practice	48
4.13	Public Transport, Footpaths, Public Accessways and Cycle Facilities	50
	Mandatory Matters	50
4.13.1	Safety from Falling.....	50
4.13.2	Public Transport	50
4.13.3	Footpaths.....	50
4.13.4	Crossings for Pedestrians and Cyclists	52
4.13.5	Cycle Facilities.....	53
4.13.6	Public Accessways	53
	Good Practice	54
4.13.7	Public Transport	54
4.13.8	Footpaths.....	54
4.13.9	Cycle Facilities.....	56
4.13.10	Crime Prevention through Environmental Design (CPTED)	57
4.13.11	Intersections and Connectivity.....	58
4.14	Road Marking and Signs	58
	Mandatory Requirements.....	58
4.14.1	Road Marking	58
4.14.2	Signs and Gateway Treatments	58
	Good Practice	59
4.14.3	Road naming	59
4.15	Streetscaping	59
	Mandatory Requirements.....	59
4.15.1	General	59
4.15.2	Grassing	60
4.15.3	Planting.....	60
4.15.4	Street Trees.....	61
4.15.5	Street Furniture.....	62
	Good Practice	62
4.15.6	General	62
4.15.7	Planting and Grassing	62
4.15.8	Street Trees.....	63
4.15.9	Street Furniture.....	63
4.16	Construction General	64
	Mandatory Matters	64
4.16.1	General	64
4.16.2	Road Assessment Maintenance Management (RAMM) Data	64
4.16.3	Earthworks.....	64
4.16.4	Earthworks Routine Testing	65
	Good Practice	66

4.16.5	Land Stability	66
4.16.6	Sedimentation and Erosion Control.....	66
4.17	Structural Design of Pavement.....	66
	Mandatory Matters	66
4.17.1	General	66
4.17.2	Submission of Test and Design Data	67
4.17.3	Basecourse and Sub-basecourse Aggregate.....	67
4.17.4	Acceptance Criteria – Pavement Strength	68
4.17.5	Acceptance Criteria – Road Profile	68
4.17.6	Stabilisation of Construction Courses	69
	Good Practice	69
4.17.7	General	69
4.18	Subgrade.....	69
	Mandatory Matters	69
4.18.1	Subgrade testing	70
4.18.2	Subgrade Drainage	70
	Good Practice	70
4.18.3	Subgrade testing	70
4.19	Carriageway Surfacing	71
	Mandatory Matters	71
4.19.1	General	71
4.19.2	Seal Design	71
4.19.3	Sealing Binder	72
4.19.4	Sealing Chip	72
4.19.5	Ground Sterilising	72
4.19.6	Application of Sealing Binder.....	72
4.19.7	Application of Chip.....	72
4.19.8	Acceptance Criteria	72
4.19.9	Dense Graded Asphalt (Asphaltic Concrete)	73
	Good Practice	73
4.19.10	General	73
4.20	Formation of Residential Lanes, Service Lanes and Private Ways	74
	Mandatory Matters	74
4.20.1	General	74
	Good Practice	75
4.20.2	General	75
4.21	Kerb and Channelling	75
	Mandatory Matters	75
4.21.1	General	75
4.21.2	Benchmarks.....	76
	Good Practice	77
4.21.3	General	77
4.22	Paths	77
	Mandatory Matters	77
4.22.1	General	77
4.22.2	Concrete Paths	77
4.22.3	Asphaltic Concrete Paths	78
4.22.4	Acceptance Criteria	78

APPENDICES

Appendix A Form 1 – RAMM Update Sheet

LIST OF TABLES

Table 4-1	Documents, Standards and References.....	3
Table 4-2	Road Safety Audit Stage Requirements.....	6
Table 4-3	Road Hierarchy.....	8
Table 4-4	Intersection Spacing above 50Km/h.....	11
Table 4-5	Target Speed Environment.....	17
Table 4-6	Minimum Provision and Width of Elements for 'Classified Roads'.....	21
Table 4-7	Minimum Provision and Width of Elements for 'Unclassified Roads'.....	22
Table 4-8	Maximum Road Gradients.....	30
Table 4-9	Safe Stopping Sight Distance.....	31
Table 4-10	Corrections due to Grade - metres.....	32
Table 4-11	Safe Intersection Sight Distance.....	34
Table 4-12	Grade corrections to ASD and SISD (cars).....	35
Table 4-13	Private Access and Crossing Design.....	39
Table 4-14	Minimum Sight Distance from Private Vehicle Access Points.....	42
Table 4-15	Minimum Distance of Vehicle Access from Intersections - metres.....	44
Table 4-16	Clear Zone Widths (With Kerb).....	46
Table 4-17	Critical Aspects of Footpath Design.....	52
Table 4-18	Primary Characteristics of Walkable Communities.....	55
Table 4-19	Crossing Facilities.....	56
Table 4-20	Design Traffic Loading ESA Minimums.....	67
Table 4-21	Maximum Pavement Deflection.....	68

LIST OF FIGURES

Figure 4-1	Performance Outcomes.....	1
Figure 4-2	Inter-relationship of Road Hierarchy.....	10
Figure 4-3	Minimum Intersection Separation in areas with a regulatory speed of 50km/h or below.....	12
Figure 4-4	Extent of Cul-de-sac – Not Permitted.....	13
Figure 4-5	Extent of Cul-de-sacs - Permitted.....	13
Figure 4-6	Cul-de-sac public accessway connection for active transport.....	14
Figure 4-7	Hammerhead and Fishtail Turning Head Arrangements.....	23
Figure 4-8	Measurement of Safe Stopping Sight Distance.....	32
Figure 4-9	Drive concept gradients for residential private access.....	41
Figure 4-10	Minimum Visibility Splay.....	43
Figure 4-11	Visibility Splay for high volume or high safety risk vehicle access points.....	43
Figure 4-12	Tracking Paths and Access- Steep hillsides only.....	44
Figure 4-13	Minimum Footpath Widths for Through Width of 1.5m.....	51

CHAPTER 4 TRANSPORTATION

INTRODUCTION

4 PURPOSE

The purpose of this chapter is to ensure that the region's transportation infrastructure is designed and constructed to meet high standards of urban design, ensuring a safe, efficient and high amenity environment for all users of the transport system.

This transportation chapter is divided into three sections to enable readers to quickly find the most relevant information for their needs:

- a) **Transport Network** - Transport Network illustrates the multitude of functions roads provide for a diverse range of users. It identifies principles for designing a transport network to accommodate the different functions and how to provide for the convenient, safe and efficient movement of various user groups.
- b) **Detailed Design** - Design identifies design principles and specifies parameters for the transport system to achieve the objectives sought from both individual roads and the wider transport network for all user groups. It recognises the importance and value of the transport asset as a public place and environments in which a range of infrastructural services are located.
- c) **Construction** - Construction specifies engineering standards that apply for the construction of particular aspects of transport infrastructure. Appropriate construction standards are essential to ensure that Council's assets are constructed to an appropriate quality. These standards allow for cost-effective and long-term benefits that consider environmental effects and optimise efficiency of Council's ongoing operation and maintenance investment.

4.1 Performance Outcomes

Transportation performance outcomes sought by these standards are far wider than simply providing for the transport service and infrastructure but extend to much broader community outcomes as shown in Figure 4-1 below and the following list in section 4.1.1.

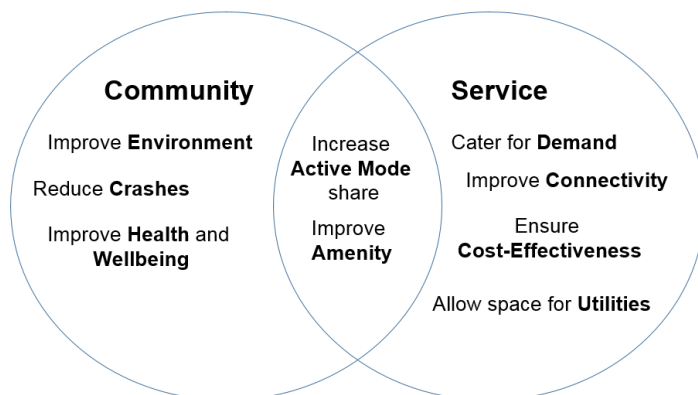

Figure 4-1 Performance Outcomes

4.1.1 Performance Outcomes - Detail

- a) A transportation network that is well connected, convenient and easy to navigate, linking residential housing, commercial and industrial activities, points of attraction, facilities and amenities in an efficient way;
- b) A transportation network that is safe for all users;
- c) A transportation network that supports a range of transportation alternatives to the private motor vehicle, including cycling, walking, mobility scooters and public transport;
- d) Transport corridors that can accommodate a range of functions, including parking, stormwater management, utilities and public spaces;
- e) Transport corridors that provide an attractive, high amenity network that recognises people's appreciation of its pleasantness, aesthetic coherence, and cultural and recreational attributes;
- f) A transportation network that has the capacity to accommodate current and future demand from all users of it;
- g) Networks that are cost-effective over the whole of life of the transportation network;
- h) A transportation network that is resilient;
- i) A transportation system that encourages and enables a shift to renewable energy sources;
- j) A transport system that does not contribute to flood hazard and manages the effects of water contamination and habitat loss from stormwater discharges;
- k) A transport system that enables positive well-being outcomes by providing active transport choices, reducing transport emissions, and providing space for people to meet and interact.

4.1.2 Creating Good Infrastructure – Design-Led Approach

The aim of this chapter is to enable good urban structure to be developed. It encourages a design-led approach rather than specification of minimum standards. This is to encourage quality thinking, collaboration and innovation to reach optimum solutions that align with the performance outcomes listed in Section 4.1 above.

A design-led approach to transportation begins with the foundation of well-designed urban structure, by acquiring a good understanding of the urban design principles which underlie the layout of blocks, streets and open spaces in new developments and the inter-relationship between them.

While the focus is on new public spaces, designers are also encouraged to consider the three-dimensional character of the spaces that are formed by buildings on private areas within the blocks. The relationship between public and private areas is an essential part of creating places for people.

Access to, and within, areas to be developed includes more than the road network that provides formal access to properties. It includes public transport routes and green linkages, such as reserves and greenways that provide access for pedestrians and cyclists

The road network and associated linkages need to be highly connected, to reflect the desire lines and destinations within the area and also in surrounding neighbourhoods. This encourages people to walk or cycle where practicable, rather than using their car, particularly for shorter local trips. When this can be achieved, it results in energy savings and creates a safer and more pleasant neighbourhood.

4.2 Referenced Documents

4.2.1 Resource Management Plan Requirements

The standards set out in this chapter address matters that are specific to Council asset creation or activities that may have an impact on an asset. These activities are also subject to the respective Nelson City and Tasman District RMPs. Key sections of the Plans that relate to transportation design and construction in this document are subdivision, land use and transportation infrastructure provisions. This means that both the provisions in the Resource Management Plans and this Land Development Manual do apply.

4.2.2 Document and Standards

This document governs a design led approach to transportation. However, additional advice and guidance can be found in Table 4-1. Where an Act or National Standards document is referenced, this must be the current version including any associated amendments.

Table 4-1 Documents, Standards and References

Standard	Comment
AS/NZS 1170	Structural Design Actions
AS/NZS 2890	Parking facilities – Part 1: Off-street car parking and Part 6: Off-street for people with disabilities
AS/NZS 4819	Rural and Urban addressing
AS/NZS 1158	Lighting for roads and public spaces
NZS 3104	Specification for concrete production
NZS 4402	Methods of testing soils for civil engineering purposes
NZS 4404	Land development and subdivision infrastructure
NZS 4431	Code of practice for earth fill for residential development
NZS 3116	Concrete segmental and flagstone paving
Austroads	Austroads Guide to Road Design: Parts 1-8
	Austroads Guide to Pavement Technology Part 2: Pavement Structural Design
	Austroads Guide to Road Safety - Part 6 Road Safety Audit at: http://www.austroads.com.au/road-operations/road-safety/resources/guide-to-road-safety
New Zealand Transport Agency	Pedestrian Planning and Design Guide
	Cycle network guidance – planning and design https://www.nzta.govt.nz/walking-cycling-and-public-transport/cycling/cycling-network-guidance
	Manual of Traffic Signs and Markings (MOTSAM) Part I – Traffic Signs & Part II – Markings
	Traffic control devices manual
	Road and Traffic Guideline RTS 14 'Guidelines for facilities for blind and vision-impaired pedestrians'

Standard	Comment
	<p>Road Safety Audit Report Template https://www.nzta.govt.nz/resources/road-safety-audit-procedures/</p> <p>Economic Evaluation Manual</p> <p>M23 Road Safety Barrier Systems</p> <p>NZTA F/1 Earthworks Construction</p> <p>NZTA F/2 Pipe Subsoil Drain Construction</p> <p>NZTA F/3 Pipe Culvert Construction</p> <p>NZTA M/1 Roothing Bitumens</p> <p>NZTA M/4 Basecourse Aggregates</p> <p>NZTA M/6 Sealing Chip</p> <p>NZTA M/10 Asphaltic Concrete</p> <p>NZTA M/13 Adhesion Agents</p> <p>NZTA P/3 First Coat Sealing</p> <p>NZTA P/9 Construction of Asphalt Concrete Paving</p> <p>NZTA P33: 2017 Coloured Surfacing</p> <p>NZTA Bridge Manual</p>
Ministry of Justice	<p>National Guidelines for Crime Prevention through Environmental Design in New Zealand.</p>
Tasman District Council Policies and Procedures	<p>Procedure for Naming Rights of Way and Private Roads https://www.tasman.govt.nz/my-council/key-documents/more/growth/development-and-financial-contributions-policy/#e1330</p> <p>Road Naming https://www.tasman.govt.nz/my-council/key-documents/more/growth/development-and-financial-contributions-policy/#e1330</p> <p>Road Delineation Policy http://www.tasman.govt.nz/policy/policies/roading-policies/road-delineation/</p>
Nelson City Council – Out and About Policy	<p>The Out and About Active Travel and Pathway-based Recreation Policy covers physical activities on Nelson roads, footpaths and pathways, either for travel or recreation purposes. http://nelson.govt.nz/council/plans-strategies-policies/strategies-plans-policies-reports-and-studies-a-z/out-and-about-policy</p>
Tasman District Council – Connecting Tasman	<p>Connecting Tasman is an overarching regional transport strategy. http://www.tasman.govt.nz/policy/policies/roading-policies/</p>

4.2.3 Transport Network

A Transportation Network Concept Plan is to be submitted to Council based on the design-led philosophy and requirements of sections 4.3, 4.4 and 4.5.

STANDARDS

4.3 Design Process

This section sets out the process of designing a transportation network that can meet the Performance Outcomes listed in section 4.1.

Mandatory Matters

4.3.1 General

The network design must be led by or include:

4.3.1.1 Performance outcomes of 4.1.

4.3.1.2 Except as provided for by f) the recommendations of a Transportation Assessment Report (TAR) by a suitably qualified and experienced transportation engineer that shows that the proposed design can meet the transport performance outcomes set out in Section 4.1. The TAR focus is on the following information:

- a) Intended speed environment of the road network.
- b) Anticipated road capacity.
- c) Points of connection within the location and with adjoining vehicle and non-vehicle accessways.
- d) Opportunities for multifunctional use of transportation corridors, such as stormwater management, reserves, amenity features and neighbourhood parking.
- e) Integration with existing and proposed bus and active transport networks; and Road function in terms of proposed development and local road hierarchy.
- f) The TAR requirement in section 4.3.1.2 may be replaced with:

“Approval at the Engineering Manager’s discretion following written advice prepared by the developer’s design team that demonstrates the proposal is not sufficiently complex to justify a TAR”.

4.3.1.3 Information that is gathered by the design team, and made available to Council as part of the transport network design process, to address the following features where applicable:

- a) Existing natural features and topography, including freshwater resources, drainage features, and soil and substrate conditions;
- b) Relevant RMP map overlay features, such as zones, area overlays, indicative roads and greenways;
- c) Existing built features within the location and within the surrounding environment, including buildings, and the location of existing stormwater reticulation, water and wastewater services;
- d) Any structure plans;

- e) Proposed stormwater management for the location, including any concept plans, resource consent approvals; and
- f) Hazards, including seismic risk locations, geotechnical instability, flood hazard, erosion and sea level rise inundation risk locations.

4.3.1.4 A road safety audit report by a team of at least two suitably qualified and experienced road safety engineers. The safety audit stage will depend on the complexity of the proposed or existing transport network, the form of its intersections and the level of active transport activity and the size of the development as shown in Table 4-2 below.

Table 4-2 Road Safety Audit Stage Requirements

Development Type	Road Safety Audit Stage			
	Concept	Scheme or preliminary design (with or prior to Resource consent application)	Detailed Design	Pre-Opening or Post Construction
Access onto, or modification to or construction of State Highway, Arterial or Principal roads	Recommended	Required	Required	Required
Access onto, modification to or construction of Collector and Sub Collector roads	Recommended	Required	Required	Recommended
Access onto, modification to or construction of Local Roads, Residential Lanes, and Service lanes	Recommended	Required	Recommended	Recommended
Access via, modification to or construction of a signalised intersection or roundabout on any hierarchy road	Recommended	Required	Required	Required
Significant active transport infrastructure (walk cycle)	Recommended	Required	Required	Required
Development involving the creation of more than 20 household units or 20 carpark spaces for non-residential activities	Recommended	Required	Required	Recommended

4.3.1.5 Exemption from providing road safety audits may be granted by the Engineering Manager at its sole discretion.

4.3.1.6 Road safety audits are to be provided for private road networks when considered necessary by the Engineering Manager.

- 4.3.1.7 Any recommendations of the Safety Audits are to be implemented by the owner/developer to the Engineering Manager's satisfaction.
- 4.3.1.8 Note: if a development involves multiple development types as listed in Table 4-2, the road safety audits will be holistic documents that covers the entire development with the highest requirement governing the number of stages required.
- 4.3.1.9 The audit procedure and report will be undertaken using the guidance set out in Austroads Guide to Road Safety - Part 6 Road Safety Audit at: <http://www.austroads.com.au/road-operations/road-safety/resources/guide-to-road-safety> and using the template provided at <https://www.nzta.govt.nz/resources/road-safety-audit-procedures>.

Good Practice

The following matters provide additional direction and guidance in the process of determining an appropriate transportation network.

4.3.2 General

- 4.3.2.1 The Designer may meet with Council Engineering and Planning staff to discuss opportunities and constraints for a transportation network based on the above information requirements of section 4.3.1.
- 4.3.2.2 Council may require additional information in support of any proposed design, and further assessment to show that performance outcomes can be met.

4.4 Network Layout Form and Function Design

This section sets out design standards for the layout, form and function of the transportation network.

Mandatory Matters

Council requires the following standards to be met in the design of the layout, form and function of the Road network:

4.4.1 Road Hierarchy

- 4.4.1.1 Each road within the proposed design must be defined in terms of its form and function according to the road hierarchy, as set out in this section.
- 4.4.1.2 All roads with a hierarchical classification of State Highway, Arterial, Principal and Collector are grouped and termed 'Classified Roads'.
- 4.4.1.3 Sub-Collector Roads, Local Roads, Residential Lanes, and Private Ways serving more than four actual or potential lots are 'Unclassified Roads'.
- 4.4.1.4 Shopping Streets will not be categorised Classified or Unclassified and will be subject to specific design.

Table 4-3 Road Hierarchy

Hierarchy	Description	ONRC ¹
State Highways	<p>State Highways are primary roads in the strategic road network linking Nelson and Tasman to other areas of the country.</p> <p>Safe and efficient mobility along the corridor will be the principal function of State Highways, with access to adjacent land being a subordinate function. State Highways will be constructed and managed by the New Zealand Transport Agency.</p>	Regional, Arterial, Primary Collector or Secondary Collector
Arterial Roads	<p>Arterial roads will be designed to join centres of population within regions and neighbouring regions and provide links to the higher order State Highway network. Safe and efficient mobility along the corridor is the principal function of Arterials with access to adjacent land being a subordinate function. Arterial roads are constructed and managed to minimise their local access function.</p>	Regional or Arterial
Principal Roads	<p>Principal roads will connect and augment the higher order transport system. These roads link adjacent suburbs, smaller centres and areas of population and facilitate movement to and access of major attractors and industrial areas.</p> <p>Principal roads will have multiple functions of moving people and goods safely and efficiently whilst also providing access to major employment areas and attractors and movement across corridors. The function of mobility along Principal roads will not dominate the management of the corridor to the detriment of access to adjacent land use.</p> <p>The effects of traffic generated by adjacent land use will not detract from the mobility function of the corridor of a Principal road.</p> <p>Principal Roads will accommodate short to medium length trips associated with through traffic and local traffic.</p> <p>Public transport, walking and cycling will be accommodated within Principal Roads.</p>	Primary Collector
Shopping Streets (Tasman) and City Streets (Nelson)	<p>Shopping Streets have a range of functions, which means a 'design led' approach is required for them.</p> <p>Therefore, they are not categorised, i.e. neither Classified nor Unclassified. Typically, these roads provide high levels of pedestrian priority, on-road parking supply, amenity, and local traffic circulation/servicing.</p>	NA

¹ One Road Network Classification (ONRC) is shown in

Table 4-3 for information only. The ONRC classification of Council's roads is its current function classification used primarily for funding and activity management purposes only.

Hierarchy	Description	ONRC ¹
Collector Roads	<p>Collector roads will be designed to distribute traffic between and within local areas and form a link between higher order (Principal and Arterial) roads and lower order (Sub-Collector and Local) roads.</p> <p>Collector Roads will be designed to accommodate local traffic and provide access to adjoining property. In the urban area, Collector roads must have a predominantly residential frontage and where required, contain the bus routes within the neighbourhood.</p>	Primary or Secondary Collector
Sub Collector Roads	<p>Sub-Collector roads will be designed to distribute the vehicular traffic at a neighbourhood level and form the link between Collector roads and Local roads. A high proportion of traffic on these roads has an origin or destination within the immediate area.</p> <p>In residential areas, Sub-Collector roads must provide high levels of amenity and prioritise access to adjoining property over local traffic movements. Through traffic is not a desired outcome for Sub-Collector roads.</p>	Secondary Collector or Access
Local Roads	<p>Local roads will be designed for the primary function of providing direct access to properties fronting the access road and along which only traffic having an origin or destination will travel. Pedestrian and local amenity values predominant.</p> <p>Local roads must also be designed to ensure a safe and high amenity environment for pedestrians and cyclists, so that the road is a shared multi-functional public space</p>	Access or Low Volume
Residential Lanes	<p>Residential Lanes are public roads that will be designed to provide access for between seven and 20 residential units.</p> <p>Residential lanes will be designed to have the visual appearance of a Private Access Way, to discourage use by non-local vehicular traffic. Vehicular and pedestrian access to frontage properties is the key function.</p>	Low Volume
Service Lanes	<p>Service Lanes will be designed for the purpose of providing side or rear access for vehicular traffic to land in industrial or commercial areas. When their construction has been completed, they may be made into private rights of way.</p> <p>No parking or separate pedestrian facilities are required to be provided on Services Lanes</p>	Low Volume
Private Access	<p>Private access includes rights of way, access lots and private driveways and are for providing access over private land to private property.</p> <p>Access to private residential areas can only serve up to six potential residential units. If there is potential for more than six residential units then a private access is inappropriate, and access should be designed to be taken from a public road.</p>	NA
Public Accessway	<p>An Accessway is a path providing pedestrian and cycle access between two or more public roads or between a road and a reserve. This is schematically illustrated in Figure 4-2. An accessway may service a number of properties along its length.</p>	NA

4.4.2 Design within the Hierarchy

When determining road form and function within the hierarchy, the following matters must be addressed in the design and discussed in the TAR:

- 4.4.2.1 Connectivity, to ensure the efficient and logical movement of people from place to place;
- 4.4.2.2 Amenity of the street and/or neighbourhood;
- 4.4.2.3 Design that encourages appropriate traffic speeds and operating conditions across the various elements of the transport network;
- 4.4.2.4 A layout that enables easy organisation and management of the transport network;
- 4.4.2.5 A layout that prioritised safety of the transport network; and
- 4.4.2.6 Choice of road that seeks opportunities to address land use and/or transport deficiencies from a number of land use or transport investment perspectives.
- 4.4.2.7 The inter-relationship of the road hierarchy is illustrated schematically in Figure 4-2.

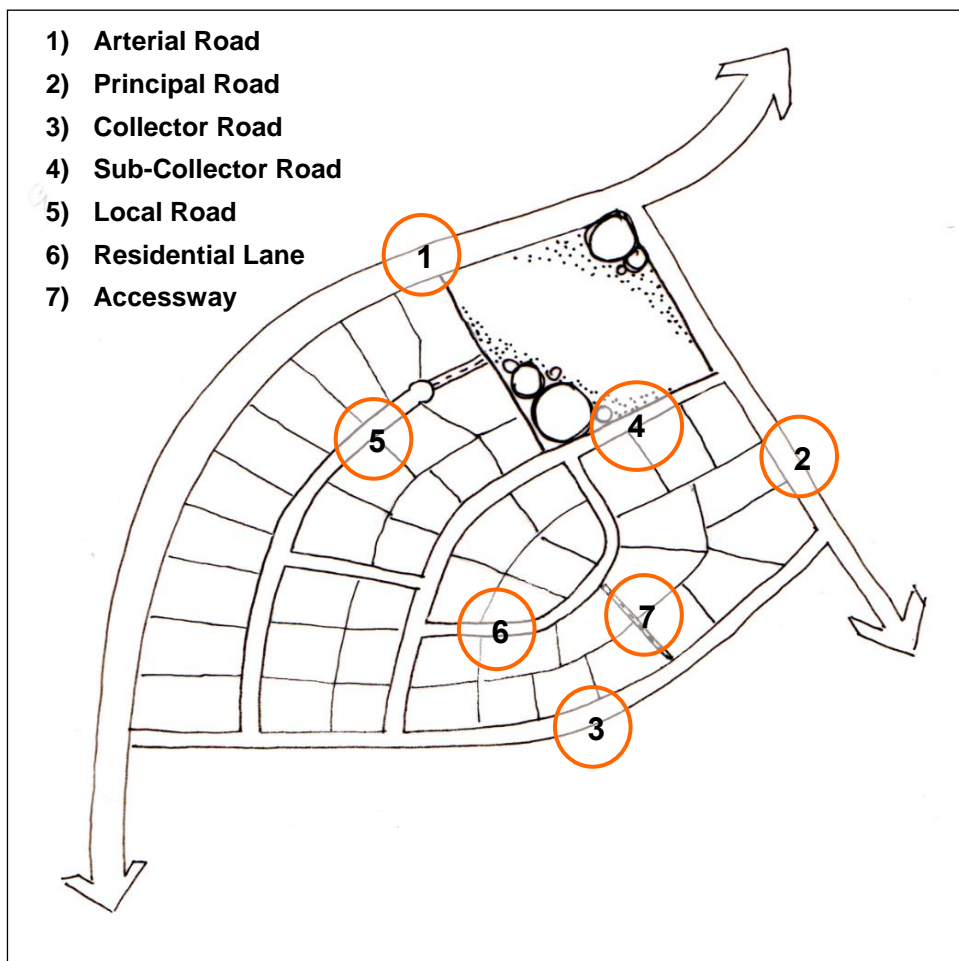

Figure 4-2 Inter-relationship of Road Hierarchy

4.4.3 Minimum Intersection Spacing

Minimum intersection spacing will be:

- 4.4.3.1 The minimum centreline to centreline separation of any two roads with regulatory speeds of 50km/h or below intersecting an urban 'Classified Road' will be 110m, increased to 150m where the intersecting roads meet the 'Classified Road' in a left-right stagger;
- 4.4.3.2 Intersections of urban 'Unclassified Roads' with regulatory speeds of 50km/h or below will provide a minimum centreline to centreline separation of 40m; and
- 4.4.3.3 The intersection spacing rules for speeds of 50km/h or below is schematically illustrated in Figure 4-3.
- 4.4.3.4 For roads with regulatory speeds above 50km/h the minimum intersection will be as show in Table 4-4.

Table 4-4 Intersection Spacing above 50Km/h

Regulatory Speed (km/h)	Minimum Intersection Spacing (m)
100	800
80	550
70	220
60	160

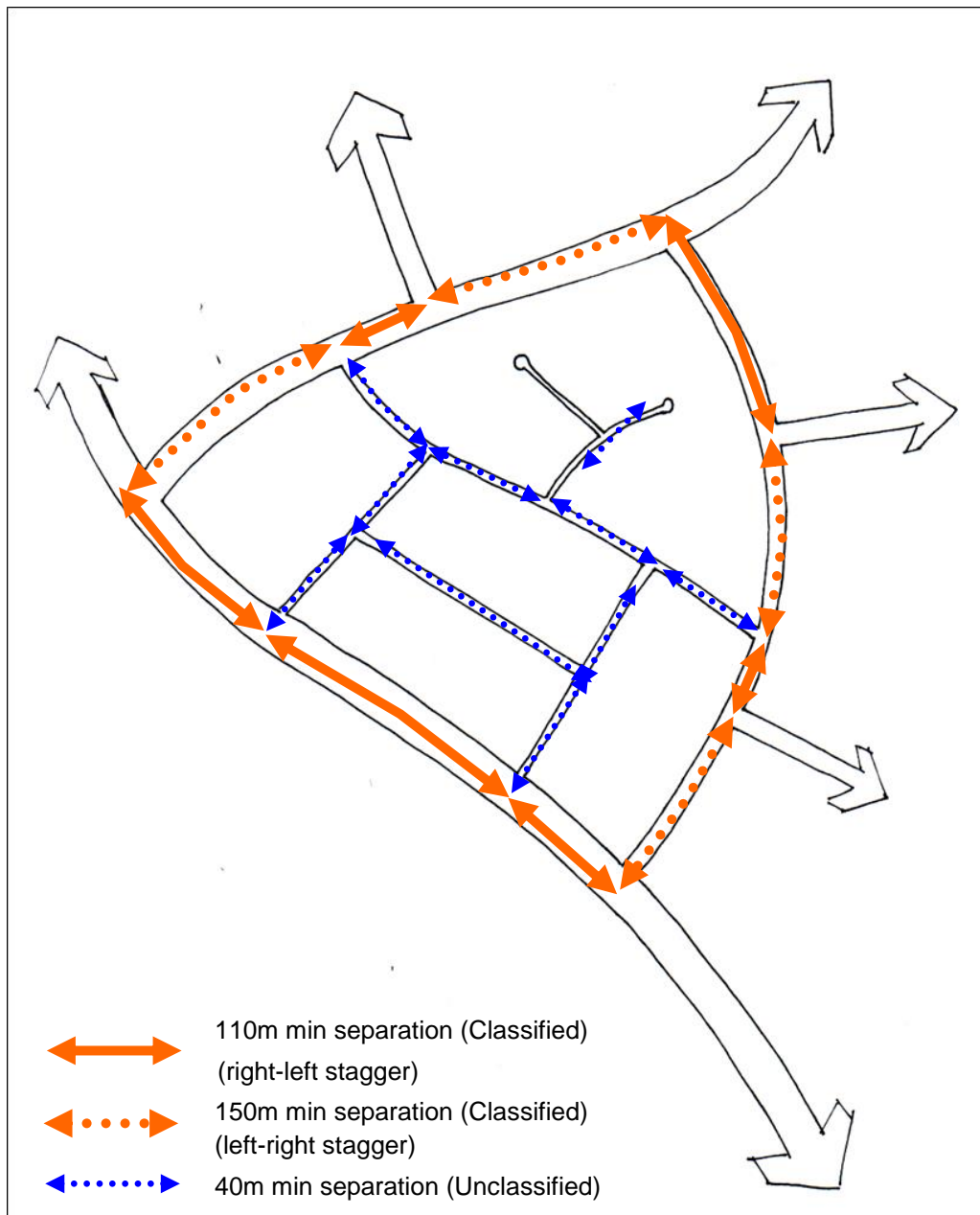

Figure 4-3 Minimum Intersection Separation in areas with a regulatory speed of 50km/h or below

4.4.4 Connectivity

- 4.4.4.1 Where future development on adjoining land is possible, land within the development will be set aside to ensure that future connection is not precluded. The spacing of road connections to adjacent future areas should consider the potential future network requirements of the wider area.
- 4.4.4.2 Cul-de-sacs that may function as future through roads must be designed to the standard of the future function.
- 4.4.4.3 Isolation strips will not be permitted when properties are developed.

- 4.4.4.4 The number and length of cul-de-sacs will be minimised, to encourage connectivity and navigability. The roading layout presented in Figure 4-4 shows a layout where the entire road network off the main road would be classified as a long cul-de-sac and is not permitted. The roading layout presented in Figure 4-5 shows how a connected road network can reduce the prevalence of cul-de-sacs.

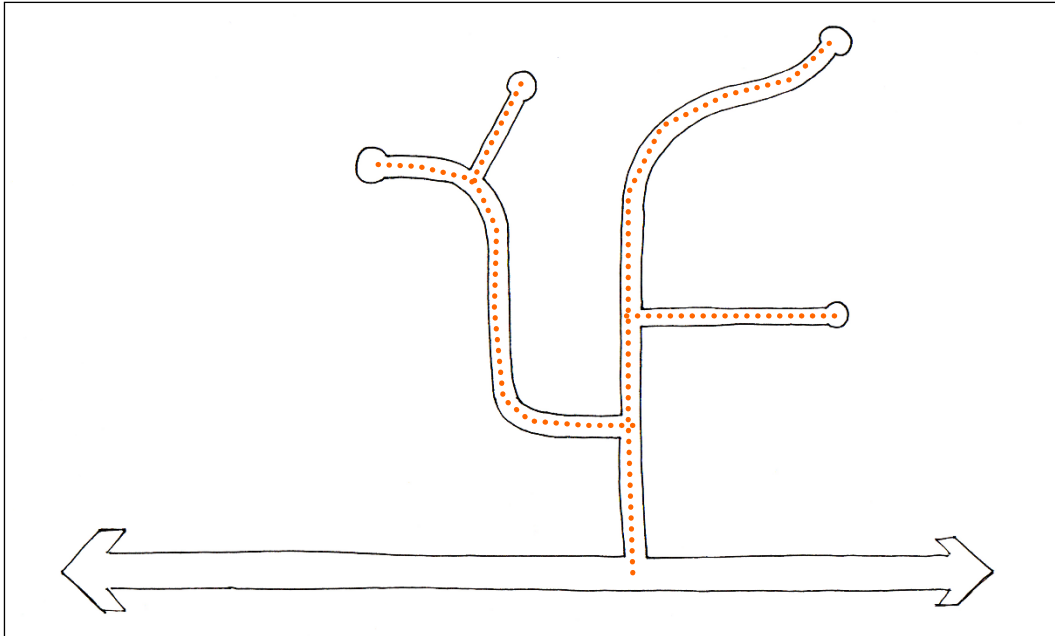

Figure 4-4 Extent of Cul-de-sac – Not Permitted

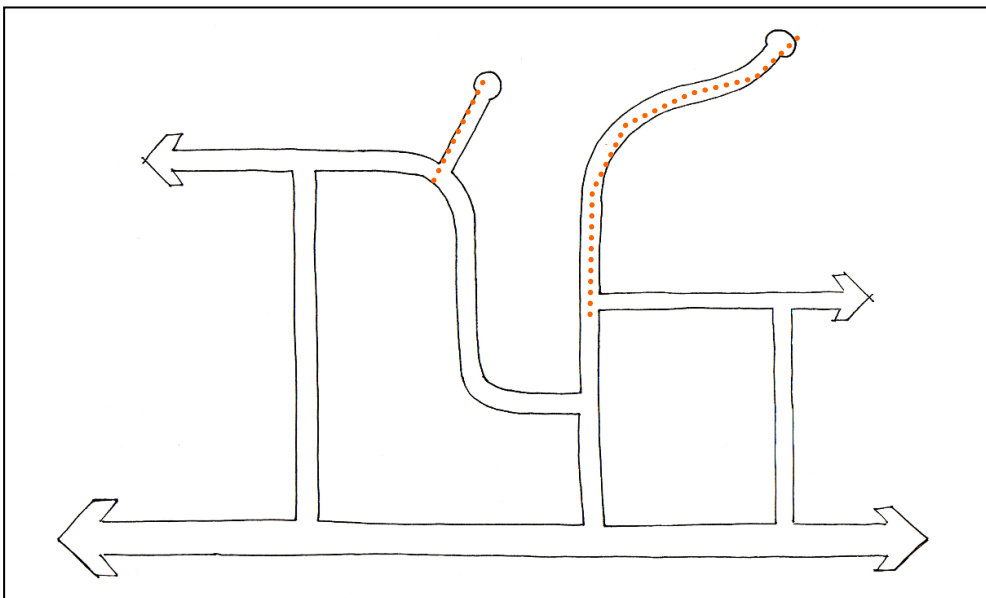

Figure 4-5 Extent of Cul-de-sacs - Permitted

- 4.4.4.5 A cul-de-sac in residential zones will be no longer than 150m and serve no more than 25 potential residential dwellings, except in 'Hillside Environments' where subject to the Engineering Manager's approval a cul-de-sac may have a length of up to 400m while serving no more than 40 potential residential dwellings.

- 4.4.4.6 No more than 15 per cent of lots in any residential zone development, except in 'Hillside Environments', will have frontage to a cul-de-sac.
- 4.4.4.7 A cul-de-sac in Commercial or Industrial zones will be no longer than 120m.
- 4.4.4.8 Cul-de-sacs must be designed so that pedestrians and cyclists have through access, especially where that access would link to local facilities, other roads or recreation opportunities, as illustrated in Figure 4-6.

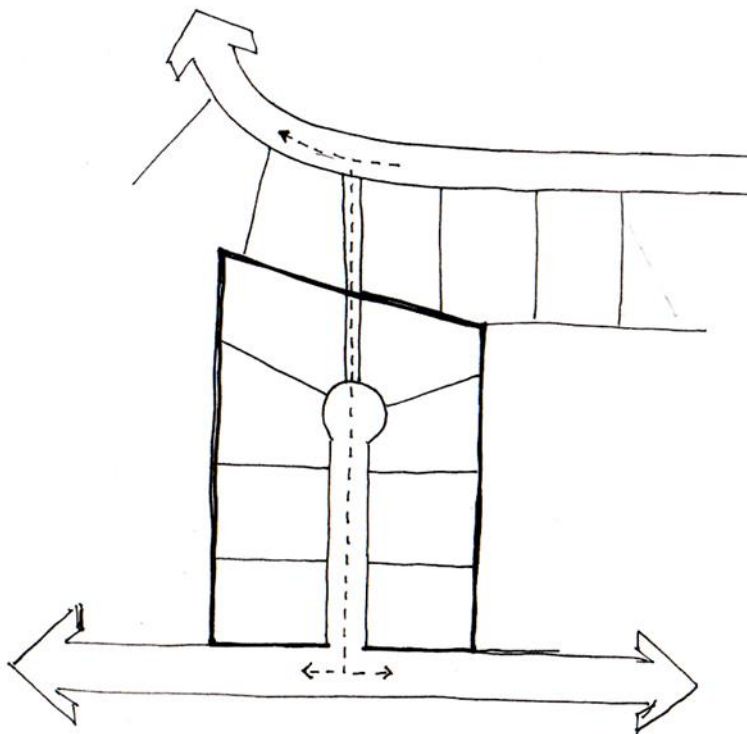

Figure 4-6 Cul-de-sac public accessway connection for active transport

4.4.5 Pedestrian, Cyclist and Public Transportation

- 4.4.5.1 The transport network must facilitate walking, cycling and use of public transport for access to daily activities.

4.4.6 Structures

- 4.4.6.1 The use of retaining walls, bridges and culverts will be subject to Engineering Manager approval.

4.4.7 Commercial Zone Design

- 4.4.7.1 The design of the commercial road layout will include a high amenity berm area for the inclusion of street furniture complementary to the commercial space such as cycle racks, litter bins, amenity planting and seating.

Good Practice

The following matters provide additional direction and guidance in the design of the layout, form and function of the road network:

4.4.8 Layout

- 4.4.8.1 The road layout and form and function design should create a permeable and highly-connected network of roads that enables relatively direct trips in and between neighbourhoods and to local activity points.
- 4.4.8.2 'Unclassified Roads' should be configured to support local traffic moving in and between neighbourhoods and areas.
- 4.4.8.3 To support the function and operation of the road hierarchy, there should be no more than two hierarchy classifications between any intersecting road. For example Local Roads should not intersect Principal Roads or Arterial Roads and Sub-Collector Roads should not intersect Arterial Roads.
- 4.4.8.4 New development should connect well to existing, committed, proposed or potential development in adjacent areas to facilitate interconnection between new and existing communities.
- 4.4.8.5 Road connections to existing areas should ensure that outcomes of the connection, such as increased traffic volumes, will be commensurate with the design of those areas.

4.4.9 Pedestrian, Cyclist and Public Transport Considerations

- 4.4.9.1 The transportation network should not only facilitate private motor vehicle travel, but also encourage walking, cycling, mobility scooter and those with impaired vision and use of public transport for access to daily activities.
- 4.4.9.2 Linkages for pedestrians and cyclists should create an attractive, friendly, connected, safe and accessible environment. These linkages should ensure that people can move about the community freely and safely in areas where there are no road linkages.
- 4.4.9.3 Large blocks (typically of more than 500m) should be avoided in urban areas, as this increases trip lengths which ultimately reduces the attractiveness of making trips by active modes.
- 4.4.9.4 The arrangement of streets, design of buildings, parks and other outdoor spaces should be designed to address crime and the level of fear of crime.
- 4.4.9.5 The layout should enhance personal safety and perceptions of safety, and minimise potential for crime, vandalism and fear by ensuring that roads and open spaces are overlooked by housing and actively used facilities to enable people to feel more comfortable outdoors.
- 4.4.9.6 To ensure that crime prevention is properly taken into account, it is important that the way in which permeability is provided is given careful consideration. A highly permeable and connected transport network is conducive to walking and cycling, but can lead to problems

of anti-social behaviour if it is only achieved by providing routes that are poorly overlooked or lack inter-visibility such as enclosed public accessways for walking and cycling.

4.4.9.7 Guidance for achieving development that provides high levels of surveillance to the transport network is provided in the Crime Prevention through Environmental Design (CPTED) Guidelines (2005). The Engineering Manager may consider variations from these principles where it is satisfied that variations are justified in terms of the following criteria:

- a) The design is constrained by topography, geology or existing development and ideal solutions are neither practical nor viable;
- b) Where compromises are desirable to maintain integrity of the network, to establish effective connections or maintain continuity along a route.

4.4.9.8 Pedestrian access should connect a high proportion of households as directly as practical to a range of facilities, including but not limited to reserves, bus stops, local shops, schools, place of employment, and medical facilities. i.e. Desire lines should be as short as practical.

4.4.10 Intersections

4.4.10.1 On 'Classified Roads' a balance should be found between achieving a permeable and connected walking network and greater importance is placed on these roads for the through movement function in urban areas.

4.4.10.2 Close intersection spacing should be avoided on busy roads to prevent:

- a) Confusing and unsafe driving environments;
- b) Reduced movement function of the corridor; and
- c) Deterring active users, as each intersection increases the pedestrian's and cyclist's exposure to a greater number of potential conflict situations from vehicles turning into and out of side roads.

4.4.10.3 Intersections on Principal and Arterial roads that are controlled by traffic signals or roundabouts should have greater separation (as assessed on a case-by-case basis) to balance movement for through traffic with the needs of local traffic and access.

4.4.10.4 Access designs for rural activities including dwellings and commercial and industrial are shown on SD409.

4.4.11 Design for Larger Vehicles

4.4.11.1 The most common type of service vehicle accessing residential areas will be those associated with regular waste collection. The operation of waste collection services should be an integral part of road design and achieved in ways that do not detract from road environment amenity.

4.4.11.2 While it is always possible to design new roads to take the largest vehicle that could be manufactured, this would conflict with the desire to create quality places and create low speed environments in local residential areas.

4.4.11.3 The design of roads will accommodate service vehicles without allowing their requirements to dominate the layout. Refer section 4.9.3.2 for large vehicle design mandatory requirements at intersections.

4.4.11.4 Larger vehicles which are only expected to use a road infrequently, such as furniture removal vehicles, need not be fully accommodated on 'Unclassified Roads'.

4.4.12 Use of Residential Lanes

4.4.12.1 Council will consider allowing a Residential Lane where:

- a) The natural or physical constraints inhibits or precludes construction of an access road to a Local Road standard; or
- b) The lane would only serve dwellings on one side, the other side borders a riparian strip or other land accessed from elsewhere; or
- c) Vehicular access is required to the rear of residential properties that have frontage, but no vehicular access to a 'Classified Road'; or
- d) A Residential Lane is the most efficient form of access for a residential intensification / infill development.

4.5 Design for the Speed Environment

This section outlines standards and guidance for the design of roads that create a safe speed environment, consistent with road form and function.

Mandatory Matters

Council requires the following standards to be met in the design of roads:

4.5.1 Design for Target Speed

4.5.1.1 The road designer will determine the target speed for each road as set out in Table 4-5.

Table 4-5 Target Speed Environment

Road Hierarchy	Classified/Unclassified	Target Speed Environment
Arterial Roads	Classified	Speed Limit
Principal Roads		Speed Limit
Collector Roads		Speed Limit
Sub-Collector Roads	Unclassified	10km/h less than speed limit *
Local Roads		20km/h less than speed limit *
Residential Lanes, Service Lanes		20km/h
Private Ways	NA	20km/h

* Assuming a speed limit of 50km/h. The target speed environment should not be below 30km/h.

In Rural Lifestyle zones the target speed environment will be a maximum of 60km/h.

- 4.5.1.2 The designer will address each of the following matters in the design of the road, to show how they have been considered in the design of the speed environment to meet the requirements of Table 4-5.
- 4.5.1.3 The width of the road and how it has been designed to encourage speed reduction;
- 4.5.1.4 Road alignment and visibility, and how these elements have been treated to encourage low speeds;
- 4.5.1.5 Road vertical elements, and their effect on the perception of the need to travel cautiously;
- 4.5.1.6 Vegetation, and the effect on visibility to reduce speed without creating traffic safety hazard;
- 4.5.1.7 Parking, and the likely demand for road-side parking as it can affect road speed behaviours;
- 4.5.1.8 Land use activities on adjoining land, especially high traffic generating ones such as schools, community amenities and commercial activities;
- 4.5.1.9 A suitably qualified and experienced traffic engineer will include within the transportation assessment report (TAR) how the proposed design will meet the target speed environment including evidence of the ability of any proposed road design to reduce speeds to the target speed.

4.5.2 Traffic Calming Devices

- 4.5.2.1 The selection of traffic calming devices must be compatible with the intended road function.
- 4.5.2.2 The selection and placement of traffic calming devices will be consistent with Austroads Guide to Traffic Management: Part 8 – Local Area Traffic Management. Any device will require Council's approval.
- 4.5.2.3 Speed humps and other vertical speed control devices cannot be used on Sub Collector, Collectors, Principal or Arterial roads nor state Highways.

Good Practice

The following matters provide additional direction and guidance in designing for the speed environment.

4.5.3 Speed Environment

- 4.5.3.1 The speed environment of roads within a transport network should reflect the function of each road in the context of the environment through which it travels.
- 4.5.3.2 Unclassified roads in residential areas should be designed to create low speed environments where pedestrians and cyclists can safely and comfortably share road space with motorised traffic.

4.5.4 Speed Reduction Measures

4.5.4.1 The following techniques can be used to achieve a lower speed environment, to make the road more conducive to accommodating all road users and improving neighbourhood amenity, including:

- a) Forward visibility – reducing lines of sight has the greatest effect on the speed environment at both intersections and at mid-block locations;
- b) Carriageway width – a narrow carriageway will generally result in a lower speed environment, especially when combined with reduced forward visibility and the presence of parked vehicles;
- c) Parking – parked vehicles generally create a speed environment that is 3 to 8km/h lower than when parking does not occur;
- d) Landscaping – appropriately designed on-road landscaping can visually narrow the road. It can also be used with changes to the kerb alignment to physically narrow the carriageway;
- e) Geometry – long, straight roads are beneficial in optimising connections between places to better serve the needs of pedestrians who prefer direct routes. However, roads with this geometry also create higher speed environments. Consideration should be given to providing short and curved or irregular roads whilst avoiding excessive or gratuitous curves that are less efficient and make access for pedestrians and cyclists more difficult;
- f) Intersection spacing – On Local roads short lengths of road between intersections make it difficult to reach higher speeds;
- g) Intersection design – small kerb radii force motorists to slow down when entering an intersection. This can be combined with an intersection treatment (for example; change in road width or surfacing) to indicate a change in the speed environment to drivers;
- h) Traffic calming – localised road narrowing, changes in road texture, changes in the road alignment (both horizontal and vertical) can all be used to reduce speeds;
- i) Thresholds – localised narrowing of the road through kerbs, road markings, signage and/or roadside planting can provide a signal to drivers that they are entering an area with a lower desired speed environment.

4.5.4.2 The above speed reduction measures do not represent a library to pick from but rather a summary of potential options for contributing to speed reduction.

4.5.4.3 Overuse of traffic calming measures will reduce their effectiveness globally, as will the passage of time reduce it locally, as drivers become familiar with them. Regardless of this, ensure a degree of consistency in the use of traffic calming measures as provided below:

- a) Use similar devices in similar ways;
- b) Design measures so that drivers can recognise and react to them appropriately both in approach speed and alignment.

4.6 Transport Cross-Sections

This section outlines Council's expectations for road widths and features to be included in the cross-section design of transport corridors.

Mandatory Matters

Council requires the following standards to be met in the design of transport cross-sections:

4.6.1 General

- 4.6.1.1 The number and minimum widths (specified in metres) of key road elements, categorised by hierarchy, are shown in Table 4-6 for Collector, Principal and Arterial Roads (Classified) and in Table 4-7 for Sub-Collector Roads, Local Roads, Residential Lanes and Service Lanes (Unclassified), see also SD411.
- 4.6.1.2 Where an existing road is developed along its frontage and that road does not have the required road reserve width, road to vest will be required along that frontage and be vested with Council without compensation.
- 4.6.1.3 As a condition of consent, the road frontage must be upgraded to the required design for that category of road at the cost of the developer.
- 4.6.1.4 Stormwater quality treatment design is required on most classified roads, refer section 5.3.8 for details.

Table 4-6 Minimum Provision and Width of Elements for 'Classified Roads'

Hierarchy	Zoning ¹	Traffic Lanes	Flush Median	Cycle Facility	Parking	Berm (Shoulder for rural)	Footpath ²	Service Strip ³	Legal Road Reserve Width ⁴
State Highway	Controlled by NZTA - Subject to specific design								
Arterial Roads	Residential (all)	2 x 3.5	1 x 2.0	Uni-directional separated paths	⁶	2 x 1.5	2 x 2.0	2 x 1.6	25
	Commercial (all)	2 x 3.5	1 x 2.0	2 x 2.3 paths with 2 x 1.0m min separating strips ⁵ to driving lane and/or 0.6m separation to parking and/or 0.2m to footpath	2 x 2.3	2 x 2.0	2 x 3.0	-	30
	Industrial (all)	2 x 3.5	1 x 2.0		⁶	2 x 1.5	2 x 2.0	2 x 1.6	25
	Rural Lifestyle (all)	2 x 3.5	-	Shared path 2 x 2.5	-	Sealed 2 x 1.5	-	-	22
	Rural (all)	2 x 3.5	-	Sealed cycle lane 2 x 2.5 ⁷	-	Sealed 2 x 1.5	-	-	20
Principal Roads	Residential (all)	2 x 3.0	1 x 2.0	Uni-directional separated paths	2 x 2.0	2 x 1.5	2 x 1.5	2 x 1.6	27
	Commercial (all)	2 x 3.0	1 x 2.0	2 x 2.3m path with 2 x 1.0m min separating strips ⁵ to parking and/or 0.2m to footpath	2 x 2.3	2 x 2.0	2 x 3.0	-	29
	Industrial (all)	2 x 3.5	1 x 2.0		2 x 2.3	2 x 1.5	2 x 1.5	2 x 1.6	28
	Rural Lifestyle (all)	2 x 3.25	-	Shared path 2 x 2.5	-	Sealed 2 x 1.5	-	-	21
	Rural (all)	2 x 3.25	-	Sealed cycle lane 2 x 2.5 ^{7&9}	-	Sealed 2 x 1.5	-	-	20
Shopping Streets	Subject to specific design								
Collector Roads	Residential (all)	2 x 3.0	-	Uni-directional separated paths	2 x 2.0	2 x 2.0	2 x 1.5	2 x 1.6	24
	Commercial (all)	2 x 3.0	-	2 x 2.0m path with 2 x 0.6m min separating strips to parking and/or 0.2m to footpath	2 x 2.3	2 x 2.0	2 x 3.0	-	26
	Industrial ⁸ (all)	2 x 3.5	-		2 x 2.3	2 x 1.5	2 x 1.5	2 x 1.6	26
	Rural Lifestyle (all)	2 x 3.0	-	1 x 2.5m Shared Path	-	2 x 600mm Metal	-	-	20
	Rural (all)	2 x 3.0	-	2 x 2.5m Sealed Cycle Lanes ^{7&9}	-	2 x 600mm Metal	-	-	20

¹ Where a road or access serves land in more than one zone the requirements for footpaths and berms on each side of the road or access will be the maximum required for any of the adjoining zones.

² Where a road fronts a reserve that has a footpath aligned parallel to, and in close proximity of the road reserve boundary, then a footpath is not required to be provided within the road reserve on that side of the road. Where a road is situated close to a school, aged care facility, church, sports field or other high pedestrian generating community facility, the footpaths to be widened to 2.0m minimum.

³ The 'Service Strip' may be reduced to 0.5m where there is sufficient space to locate services under the footpath without precluding the introduction of street trees.

⁴ The final legal road reserve width may vary from the legal road reserve width shown in Table 4-6. The indicative legal road widths assume that all elements are provided to the minimum width and located alongside one another with no cut or fill batters.

⁵ A narrower Road Reserve width will be acceptable to Council if the 'Berm' and cycle facility separating strip are able to be combined into a single 1.5m landscaped strip except in the Commercial zone.

⁶ If there is existing parking demand then provide 2.0m width in residential zones and 2.3m width in industrial zones.

⁷ Cycle separating strips and the berm area should be combined, subject to specific design that considers operating speed, appropriate separation, heavy vehicle, vehicle and cycle volumes.

⁸ Zoning refers to the generic zone reference in zone terminology of Chapter 3 – Definitions.

⁹ The cycle facility in rural zones may be omitted if there is no current or future demand at the sole discretion of the Engineering Manager.

Table 4-7 Minimum Provision and Width of Elements for 'Unclassified Roads'

Hierarchy	Zoning ¹	Traffic Lanes	Cycle Facility	Parking	Berm ² (Shoulder for Rural)	Footpath ^{2&3}	Service Strip ⁴	Legal Road Reserve Width
Sub -Collector Roads	Residential (all)	1 x 5.6	- ⁸	1 carpark/2 dwellings ⁷ Or 2 x 2.0	Min 0.3m, Max 6.0m Area ≥ 3.0m ² /lm averaged over 50m Or 2 x 1.5	2 x 1.5	2 x 1.6	19
	Commercial (all)	1 x 5.6	- ⁸	2 x 2.3	2 x 2.0	2 x 3.0	-	21
	Industrial (all)	2 x 3.25	- ⁸	2 x 2.3	2 x 1.5	1 x 1.5	2 x 1.6	19
	Rural Lifestyle (all)	1 x 6.0	1 x 2.5m Shared Path	-	2 x 600 Metal	-	-	16
	Rural (all)	1 x 6.0	1 x 2.5m Shared Path ⁹	-	2 x 600 Metal	-	-	16
Local Roads	Residential (all)	1 x 5.5	- ⁸	1 carpark/2 dwellings ⁷ Or 2 x 2.0	Min 0.3m, Max 6.0m Area ≥ 3.0m ² /lm averaged over 50m Or 2 x 1.5	2 x 1.5	2 x 1.6	19
	Residential (< 20 dwellings) (all)	1 x 5.5 ^{5&6}	- ⁸	1 carpark/2 dwellings ⁷ Or 2 x 2.0	Min 0.3m, Max 6.0m Area ≥ 3.0m ² /lm averaged over 50m Or 2 x 1.5	1 x 1.5	2 x 1.6	13
	Commercial (all)	1 x 5.6	- ⁸	2 x 2.3	2 x 2.0	2 x 3.0	-	21
	Industrial (all)	2 x 3.25	- ⁸	2 x 2.3	2 x 1.5	1 x 1.5	2 x 1.6	19
	Rural Lifestyle (all)	1 x 6.0	1 x 2.5m Shared Path	-	2 x 600mm Metal	-	-	14
Rural (all)	1 x 6.0	1 x 2.5m Shared Path ⁹	-	2 x 600mm Metal	-	-	14	
Residential Lane ¹⁰	Residential (7 to 20 dwellings)	1 x 5.5 ^{6&7}	-	2.2 Indented bays ⁷	Min 0.3m, Max 6.0m Area ≥ 1.5m ² /lm averaged over 50m Or 1 x 1.5	1 x 1.5	1 x 0.5	9 ¹¹

¹ Where a road or access serves land in more than one zone the requirements for footpaths and berms on each side of the road or access will be the maximum required for any of the adjoining zones.

² In 'Hillside Environments' on unclassified roads in Nelson the berm and footpath may be excluded from the uphill side of the road. In Tasman "Hillside Environments" all roads, berms and footpaths require careful specific design to the satisfaction of the Engineering Manager.

³ Where a road fronts a reserve that has a footpath aligned parallel to, and in close proximity of the road reserve boundary, then a footpath is not required to be provided within the road reserve on that side of the road. Where a road is situated close to a school, aged care facility, church, sports field or other high pedestrian generating community facility, the footpaths to be widened to 2.0m minimum.

⁴ The 'Service Strip' may be reduced to 0.5m where there is sufficient space to locate services under the footpath without precluding the introduction of street trees.

⁵ Passing bays will be provided at least every 50m or where appropriate. Mutual driveways may be used as passing bays. The minimum dimensions for a passing bay are a width of 5.5m (including carriageway) and minimum length of 6.0m with a 4.0m long taper at each end).

⁶ The requirement is 5.5m for the first 12m from any intersection with higher order roads (Local Roads and above). Thereafter, the traffic lane width may be narrowed to 3.5m. Mutual driveways will be provided at adjoining lot boundaries (12.0m total width) to function as passing bays at least every 50m. The minimum dimensions for a passing bay are a width of 5.5m (including carriageway) and minimum length of 6.0m with a 4.0m long taper at each end).

⁷ Refer clause 4.12.1.1

⁸ Cycle facilities not required provided design allows shared space with low speed environment.

⁹ The cycle facility in rural zones may be omitted if there is no current or future demand.at the sole discretion of the Engineering Manager

¹⁰ A road will only be designed and constructed as a Residential Lane with the prior approval of the Engineering Manager when considering the factors in section 4.4.12.

¹¹ The final legal road reserve width may vary from the legal road reserve width shown in Table 4-6. The indicative legal road widths assume that all elements are provided to the minimum width and located alongside one another with no cut or fill batters.

4.6.2 Shoulder Design

- 4.6.2.1 The shoulder will be widened to 2.5m on the outside of any curve less than 1000m radius on rural classified roads in accordance with Austroads Part 3 Guide to Rural Road Design section 4.3.4, to allow erring drivers to be able to recover safely back onto the road.

4.6.3 Flush Medians

- 4.6.3.1 Flush medians will be widened at intersections and at the access to high traffic generating activities to accommodate turning bays.
- 4.6.3.2 Flush medians that accommodate a pedestrian and or cycle island must be at least 2.4m wide. For marking details refer to the NZTA Manual of Traffic Signs and Markings (MOTSAM) Part II – Markings.

4.6.4 Turning Area Design

- 4.6.4.1 A turning facility will be provided at the end of all cul-de-sacs.
- 4.6.4.2 The minimum radius of the turning circle of a cul-de-sac will be 7m in residential zones, 11m in commercial, 12m in industrial areas and 8.0m in rural lifestyle areas, as per SD417 'Cul-de-sac Turning Circles'.
- 4.6.4.3 Residential Lanes that have only one intersection with higher order roads must be designed with a turning area at the head.
- 4.6.4.4 The berm or shoulder just prior to the turning area will be designed to incorporate collection areas for waste and recycling collection services as shown in SD417. This is to minimise the health and safety risk of multiple reverse manoeuvres from the refuse vehicle lining up with bins within the turning area. The collection area will be 1.0m² for each property accessed from the turning head.
- 4.6.4.5 For residential cul-de-sacs and Residential Lanes in Nelson 'Hillside Environments' the turning area may be a 'Hammerhead' or 'Fishtail' layout, as indicated in Figure 4-7 provided it is sufficient to allow an 8m medium rigid truck with 10m turning radius to undertake a three-point turn. In Tasman hammerhead or fishtail layouts may be used at the sole discretion of the Engineering Manager.

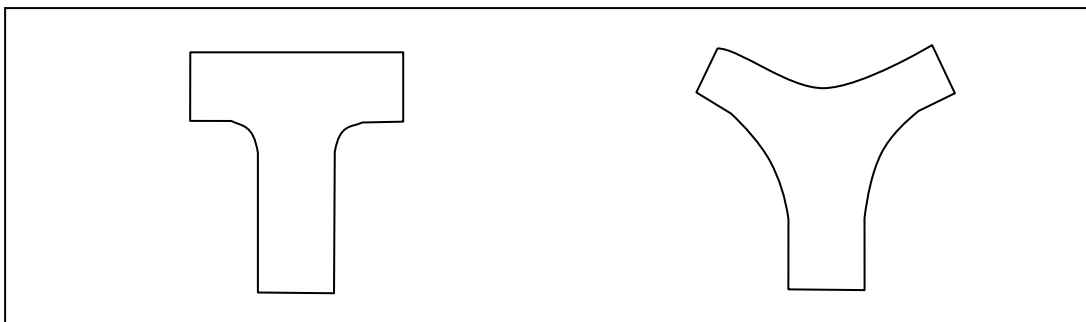

Figure 4-7 Hammerhead and Fishtail Turning Head Arrangements

4.6.5 Staged Road Construction Ends

- 4.6.5.1 Where a road is developed/constructed in stages a turning area will be provided at the end of the construction on the balance land or within at least 20m of the end of the road and be formed, so that all lot frontages can be developed fully, and have access to the legal road. The pavement will be formed to the same standard as the road and permanently surfaced to provide an area sufficient to allow a three-point turn by an 8m medium rigid truck with 10m turning radius.
- 4.6.5.2 Staged road end turning areas must be located within the road reserve area.
- 4.6.5.3 Staged road end turning areas will be removed when the next stage is developed and kerb lines and other associated road elements such as footpaths, streetlights and shoulders extended through at the typical road width to ensure good alignment readability and to minimise the sealed area and its associated ongoing maintenance liability.
- 4.6.5.4 If a lot is created with two road frontages in, then both roads shall be constructed and vested in Council in the one stage. (This allows full development of the corner section and access off the lesser road and connectivity for future landowners). In the unlikely event that a site/lot has vehicle access via one road and also frontage (no vehicle access) to a different road (not a corner site) then road upgrades will be addressed on a case by case basis.

4.6.6 Service Lanes

- 4.6.6.1 Service lanes must:
- Have at least two intersections with higher order roads. Service lanes must not be designed as a cul-de-sac;
 - Have a minimum carriageway width of 4m. Separate parking or pedestrian facilities are not required to be provided.

4.6.7 Services

- 4.6.7.1 The layout of all roads must accommodate infrastructural services and provide convenient access for the maintenance of those services.
- 4.6.7.2 Services are not permitted to be located in the berm between the footpath and the kerb, as this will preclude the planting of street trees. Where street trees are not proposed, the water pipe may be located in this area.
- 4.6.7.3 The width between the kerb and property boundary must be designed to provide sufficient clearance between services. In addition, there must be at least 600mm horizontal separation between the power and the property boundary (refer SD412 and SD413).
- 4.6.7.4 Where street trees are planned, sufficient space must be allowed for them outside of the service corridor with sufficient clearance so that services are not damaged by roots as the trees grow.
- 4.6.7.5 For upgrades to existing roads or the provision of new services in existing roads, services may be located under the service strip adjacent to the property boundary or under the footpath.

Good Practice

The following matters provide additional direction and guidance in the design of transport cross-sections:

4.6.8 General

4.6.8.1 The planning and incorporation of bus routes into a new subdivision should be included as part of the subdivision application. Roads that accommodate or may accommodate a future bus route should be designed in accordance with the requirements specified in Section 4.13.2 Public Transport.

Council may consider variations from Table 4-6 and

4.6.8.2 Table 4-7 where alternative cross-sections and supporting analysis is provided in the TAR.

4.6.9 Legal Road Widths

4.6.9.1 The width of the legal road reserve and carriageway should be sufficient to cater for all functions that the road is expected to fulfil, given the existing zoning of the site and surrounding land, including safe and efficient movement of all users, provision for parking, buffering residents against traffic nuisance, provision of utilities, transport infrastructure, stormwater management, retaining structures and streetscape features.

4.6.9.2 Some of the common factors that will affect the indicative legal road widths are:

- a) On road parking in residential areas may be provided as indented or angled parking bays within the berm area resulting in a variable berm width and ability to introduce a curvilinear alignment to reinforce slow speeds and potentially a narrower overall legal road width;
- b) Where services are located under the footpath in 'Hillside Environments' (refer SD413) the service strip may be reduced to 0.5m;
- c) Cycle facilities, their separation zones and berm areas may be able to be combined. This will result in a narrower overall legal road width;
- d) Some elements may not be required in 'Hillside Environments' to minimise the adverse environmental and amenity effects created by excessive earthworks;
- e) The use of water sensitive design stormwater methods such as swales, which are likely to require additional berm width refer section 5.3.8;
- f) Wider legal road widths may be required to accommodate road retaining structures or earthwork batters.

4.6.9.3 The cross section of new roads or the upgrade of existing ones should take into account the road function, the operating objectives, and the type, density and character of surrounding development.

4.6.9.4 However, on all roads, especially in residential areas, meeting the needs of motorists should not be to the detriment of pedestrians, cyclists and public transport users. Care should be taken to avoid unnecessarily wide roads and verges as this can encourage higher traffic speeds, reduce the amenity of the adjoining land, and discourage pedestrian activity.

4.6.10 Flush Medians

4.6.10.1 Flush medians are intended primarily for urban speed environment conditions with regulatory speeds of 70km/h or less.

4.6.10.2 Flush medians may be appropriate when:

- a) Right turning traffic is interfering with through traffic with the potential for crashes or problems with delays entering the traffic stream;
- b) Pedestrians are having difficulty crossing a busy road;
- c) The carriageway is excessively wide; or
- d) Property access needs to be maintained and any of the above conditions exist.

4.6.11 Turning Areas

4.6.11.1 The road area for manoeuvring should be kept to a minimum to minimise road and land area waste.

4.6.11.2 Opportunities should be taken to incorporate design features such as landscaping, street furniture and central parking spaces to make these areas attractive focal points. Turning areas require a lot of road space and they are generally wasteful in land terms.

4.6.12 Shoulders

4.6.12.1 The shoulder width is measured from the edge of the traffic lane to the berm.

4.6.12.2 All roadside furniture, including landscaping should be located outside the shoulder wherever possible.

4.7 Batter Slope, Bridge and Retaining Structure Design

Batter slopes, retaining walls and bridges are high value components of the transport system with long lives and high ongoing maintenance costs thus getting the design right is critical.

Mandatory Requirements

The following matters are mandatory where slopes or bridge and retaining structures are a factor in the design of the transport system:

4.7.1 Batter Slope

4.7.1.1 All new cut faces must be retained or stabilised with grass.

4.7.1.2 In flat terrain, the bottom edge of the fill batter or the top of a cut batter will start at least 600mm on the roadside of the property boundary. In 'Hillside Environments', the toe of the cut batter may start 1m from the kerb or back of footpath, and the top of the fill batters may start 1m from the kerb or back of footpath (see SD414).

- 4.7.1.3 No batter in either cutting or filling will be steeper than 1.0 vertical to 1.5 horizontal (67%) without the approval of the Engineering Manager, and in certain cases, a geotechnical assessment by a Chartered Professional Engineer (P.Eng.Geol.) will be required to establish the safe batter slope and specific low maintenance landscaping/vegetation that is required, other than grass, see 4.7.1.1.
- 4.7.1.4 In “Hillside Environments” all batters require specific design to the satisfaction of the Engineering Manager.
- 4.7.1.5 Where a batter is not required to cater for foot traffic, grassed batters are permitted, to a maximum of 1-in-4 (25%) to ensure they are mowable.

4.7.2 Support and Retaining Structures and Bridges

- 4.7.2.1 Stabilised faces, retaining structures or bridges that support private assets or property:
- a) Must be located outside of the legal road reserve. These faces and structures are the sole responsibility of the property owner whose land they support;
 - b) Will have certified design plans submitted to Council and a building consent, or exemption under Schedule 1 of the Building Act obtained.
- 4.7.2.2 Stabilised faces, retaining structures or bridges supporting the operation of the transport network must:
- a) Be located within the legal road reserve. This may require adjustment of the legal road boundary to ensure 1.0m minimum clearance from the toe or top of the wall or bridge structure to the boundary is vested to Council. If the structure is taller than 3.0m then 2.5m minimum clearance is required to be added to the road reserve to ensure Council can maintain and replace the structure in perpetuity. This greater area to vest may be provided by way of easement in favour of Council;
 - b) Have a design life of 80 years minimum;
 - c) Be designed in accordance with the NZTA Bridge Manual and have a design loading of HN-HO-72, unless the requirements of Appendix D of the NZTA Bridge Manual apply for lightly trafficked structures applies, then the design loading will be 0.85HN;
 - d) Be designed by and the construction supervised by a Chartered Professional Engineer (CP Eng) with producer statements PS1 and PS4 submitted to Council;
 - e) Have an engraved brass plaque fixed to the bridge showing its design loading;
 - f) To improve visual amenity retaining walls will be of the minimum height necessary;
 - g) Vegetated retaining walls including crib walls are not permitted;
 - h) Bridges will have a 500mm freeboard at Q100 -2100 flood levels and hydraulic evidence must be submitted to Council;
 - i) The design of all retaining structures supporting the transport network or areas likely to have buildings erected within the area between the wall and a line measured at 45 degrees to horizontal from the base of the wall, will include specific information from the Designer’s Professional Advisor (DPA). This information will include what design and construction methods will be implemented to ensure that future settlement of the ground behind the wall and the ground surface will be no greater than 20mm over a 6m horizontal length;
 - j) Design plans must be submitted to Council for comment prior to construction.

4.7.3 Geotechnical Risk Areas

- 4.7.3.1 In ground that may be subject to instability, including settlement as a result of severe seismic shaking causing liquefaction of the underlying subsurface materials the design of the transport system will be undertaken to the satisfaction of the Engineering Manager, by a Chartered Professional Engineer practising in geotechnical engineering and experienced in transport design. This includes but is not limited to Hillside Environments (Nelson), the Tahunanui Slope Hazard Area or Slope Instability Risk Areas (Tasman).
- 4.7.3.2 Consideration will be made with regard to transport design so as to avoid or mitigate against the possible effects arising from severe seismic ground shaking.

4.7.4 Sub-soil Drainage

- 4.7.4.1 Sub soil drains installed to for the purpose of dewatering retaining walls embankments, cuttings and the subgrade to supporting the construction on ongoing performance of the transport network will be wholly located within the road reserve.
- 4.7.4.2 Subsoil drains should comprise a minimum 110mm diameter slotted pipe surrounded with 100mm minimum of free draining drainage metal. Drains will be excavated into firm ground and will be linked together at a minimum grade of 1:250 and extended to connect into an approved stormwater system. Refer to NZTA F:2 specification for pipe subsoil drain construction for further detailed guidance.
- 4.7.4.3 Approved filter fabric material to NZTA F:7 specification will be placed between the drainage metal and in-situ or fill material.

Good Practice

The following matters provide additional guidance and direction regarding slope and stability design:

4.7.5 Hillside Construction

- 4.7.5.1 Roads should generally follow the natural contours of the land and should not be placed perpendicular to contour lines unless absolutely unavoidable. Curvilinear road alignments are preferred to influence a lower speed environment.
- 4.7.5.2 Cut and fill will be kept to a minimum to avoid earthworks altering the natural land form and avoiding removal of natural features, including vegetation.
- 4.7.5.3 A balance should be achieved between complying with design standards and minimising the adverse effects that excessive earthworks can create, such as visual pollution and high construction and maintenance costs.

4.7.6 Land Stability

- 4.7.6.1 Where in the opinion of the Council the stability of any embankment as planned is in doubt, then the Council may require a stability analysis of the slope, under saturated condition to be carried out (see also AS/NZS 1170: Structural Design Actions or the NZTA Bridge Manual).

4.7.7 Retaining Walls

4.7.7.1 Generally retaining walls should be constructed of either (or a combination of) the following types:

- a) Concrete cantilever with precast face;
- b) Concrete Pile Palisade;
- c) Concrete Pile Palisade with ground anchors;
- d) H6 Timber pole piles with timber lagging;
- e) H6 Timber pole piles, ground anchors and H5 timber lagging;
- f) Steel pole piles with H5 timber lagging;
- g) Steel pole piles, ground anchors, and H5 timber lagging;
- h) Galvanised wire, plastic coated mesh gabion.

4.7.7.2 Council may consider deviations from mandatory matters provided in the Land Development Manual for sites that are topographically constrained or to minimise the effects of earthworks.

4.7.7.3 The type of deviations that the Councils' may consider for hillside construction include:

- a) Providing narrower legal road widths. Wider widths may be impractical as it may be impossible to utilise more than a certain width due to crossfall restrictions. Private access may also be compromised if wide roads require high cuts or retaining walls;
- b) Provide for on-road parking in parking bays as an alternative to continuous kerbside parking lanes;
- c) Provide a lesser standard of elements, such as constructing only one footpath. Where only one footpath is provided it should generally be on the downhill side of the road;
- d) Locate pedestrian and cycle facilities separately from the carriageway.

4.8 Road Geometry

This section sets out requirements for the geometric design of road gradients, crossfall, elevations and safe stopping sight distances.

Mandatory Requirements

The following matters are requirements for the design of roads in terms of road geometry:

4.8.1 Gradients

4.8.1.1 Gradients are measured on the inside of any curves at the edge of the traffic lane.

4.8.1.2 Kerb grades will not be less than 1-in-250 (0.4%).

4.8.1.3 Road gradients will not be steeper than those values specified in Table 4-8.

Table 4-8 Maximum Road Gradients

Road Hierarchy	Maximum Gradient *
Arterial Roads	1-in-20 (5.0%)
Principal Roads	1-in-15 (6.7%)
Collector Roads	1-in-10 (10.0%)
Sub-Collector Roads	1-in-8 (12.5%)
Local Roads	1-in-7 (14.3%)
Residential Lanes	1-in-6 (15.8%)

* Gradients on bus routes will not be steeper than 1-in-15 (6.7%)

The average gradient (local roads and residential lanes) over 50m will not exceed 1-in-6 (16.7%)

4.8.2 Crossfall

- 4.8.2.1 The default normal crossfall of 1-in-33 (3%) in both directions from the crown will be developed on all standard sealed carriageways.
- 4.8.2.2 Where asphaltic concrete is used the crossfall will be no flatter than 1-in-50 (2%) unless on a curve associated with the application of super-elevation.
- 4.8.2.3 Where a uniform crossfall is developed from kerb-to-kerb, this will not be flatter than 1-in-50 (2%).
- 4.8.2.4 All stormwater from the carriageway and footpaths on roads and private ways will be collected by an approved stormwater system. Refer to Chapter 5 Stormwater, of the NTLDM for design and construction guidance on stormwater matters.

4.8.3 Super Elevation

- 4.8.3.1 Super-elevation is not required in areas with a speed limit of 60km/h or below.
- 4.8.3.2 On roads where the speed limit is over 60km/hr, specific design of super-elevation is required.

4.8.4 Horizontal curves

- 4.8.4.1 Curves on all classified roads and roads with a speed limit above 50km/h will be transitional.
- 4.8.4.2 Circular curves are permitted on unclassified roads with regulatory speed limits of 50km/h or less.
- 4.8.4.3 Horizontal curves in 50 km/hr zones must have a minimum centreline radius of:
 - a) 80m for roads in the industrial zone;
 - b) 25m radius for Local Roads in residential areas and Residential Lanes with associated widening to the inner edge to enable large vehicles to safely negotiate curves in one pass; and;
 - c) 40m for roads in all other zones.

4.8.4.4 If reverse curves are necessary, they will have a design speed difference of no greater than 10km/h and be separate by a sufficient length of straight road to allow for development of super-elevation reversal at no greater than 2.5m/s/s (where the design speed is greater than 50km/hr).

4.8.4.5 Curves in the same direction (i.e. broken back) in close proximity are not permitted.

4.8.5 Safe Stopping Sight Distances

Safe Stopping Sight Distance (SSSD) is the distance required for a vehicle to safely stop between the time when the driver reacts to a conflict situation and the time the vehicle comes to rest.

4.8.5.1 Table 4-9 shows acceptable SSSD for various design speeds. For full details refer Austroads Guide to Road Design: Part 3 – Geometric Design, section 5.3.

4.8.5.2 SSSD is important in the design of 'Unclassified Roads' (roads that generally do not require a centreline to be marked) to ensure that sufficient visibility is provided between opposing vehicles on narrow carriageways to see each other and stop.

4.8.5.3 SSSD is also important to ensure adequate inter-visibility between transport users and to provide visibility to traffic management devices.

Table 4-9 Safe Stopping Sight Distance

Design Speed	Safe Stopping Sight Distance (m) $R_T = 2.0s$ *
≤ 30 km/h	25
40 km/h	40
50 km/h	55
60 km/h	73
70 km/h	92
80 km/h	114
90 km/h	139
100 km/h	165

* As required on level grade. Correction factors are to be applied on non-level roads in a manner that is consistent with Austroads Guide to Road Design: Part 3 – Geometric Design section 5.3. See Table 4-10 below.

Table 4-10 Corrections due to Grade - metres

Corrections due to grade	-8%	-6%	-4%	-2%	2%	4%	6%	8%
40 km/hr	5	3	2	1	-1	-2	-2	-3
50 km/hr	8	5	3	2	-1	-3	-4	-5
60 km/hr	11	8	5	2	-2	-4	-6	-7
70 km/hr	15	11	7	3	-3	-5	-8	-10
80 km/hr	20	14	9	4	-4	-7	-10	-13
90 km/hr	25	18	11	5	-5	-9	-13	-16
100 km/hr	31	22	14	6	-6	-11	-16	-20

4.8.5.4 SSSD is measured both in relation to vertical and horizontal curvature as illustrated in Figure 4-8.

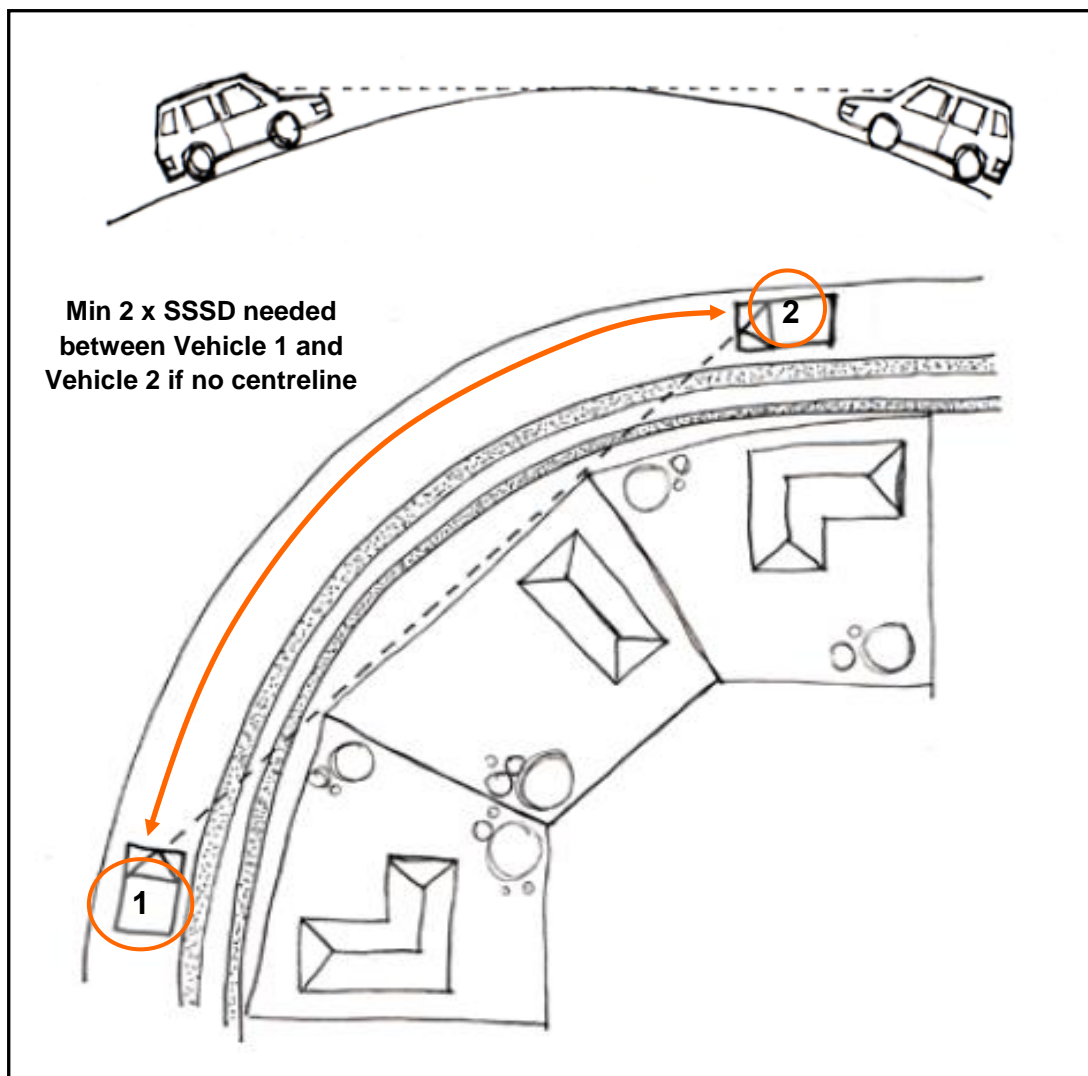

Figure 4-8 Measurement of Safe Stopping Sight Distance

4.8.5.5 On roads where two times the SSSD cannot be achieved, a centreline must be marked. This is likely to require the banning of kerbside parking and may require carriageway widening.

Good Practice

The following matters represents additional guidance and direction in regard to road geometry:

4.8.6 Gradients

- 4.8.6.1 At road intersections it is important that the crown of the intersecting road does not extend out into the carriageway of the through road, to maintain vehicle stability. Normally, this means running the crown of the minor road into the nearside edge of the main road lane line or quarter point.
- 4.8.6.2 Where the kerb levels differ for design purposes, crossfalls varying from 1 in 50 (2%) to 1-in-20 (5%) from the crown may be permitted, coupled with a lateral shift in crown position of up to one quarter of the carriageway width.
- 4.8.6.3 Council will consider steeper gradients on a case-by-case basis and these may be permitted over short lengths, but the Council reserves the right to impose special conditions of construction. Grades should be as long as possible and vertical curves provided at all changes of grade.

4.8.7 Super-Elevation

- 4.8.7.1 In 'Hillside Environments' super-elevation may be employed where it suits boundary levels up to the allowable design maximum crossfall of $\pm 6\%$.

4.8.8 Kerb Lines

- 4.8.8.1 Kerbs should be at the same level on both sides of the road however in some circumstances, the left and right-hand kerb lines may be better graded individually in conjunction with centre line levels, footpath levels and boundary levels. Under such circumstances, at a given cross section, the left and right-hand kerbs maximum difference in kerb level = 120mm + 15mm/m for roads with a carriageway wider than 7.0m.

4.9 Intersection Design

This section provides standards and guidance on matters relating to intersection design.

Mandatory Requirements

The following matters are required in the design of intersections:

4.9.1 General

- 4.9.1.1 Intersections will be designed to improve the legibility of the transport network and reinforce the function of the intersecting roads as defined by the road hierarchy.
- 4.9.1.2 The design of unsignalised and signalised intersections will be in accordance with Austroads Guide to Road Design Part 4A – Unsignalised and Signalised Intersections.
- 4.9.1.3 The design of roundabouts will be in accordance with Austroads Guide to Road Design Part 4B – Roundabouts.

- 4.9.1.4 The design of cycle facility intersections will be in accordance with NZTA's Cycling Network Guidance and Austroads Guide to Road Design Part 6A Paths for Walking and Cycling.
- 4.9.1.5 The road marking and sign layout at all intersections types will be in accordance with the NZTA Manual of Traffic Signs and Markings (MOTSAM) and NZTA Traffic Control Devices Manual.
- 4.9.1.6 Intersections will not be designed to be a stop control.

4.9.2 Sight Distances

- 4.9.2.1 Safe Intersection Site Distance (SISD) is the minimum sight distance that should be available from intersection legs with priority to vehicles which could emerge from non-signalised legs. It is measured along the carriageway from the approaching vehicle to the conflict point. For full details refer Austroads Guide to Road Design: Part 4A – Unsignalised and Signalised intersections, section 3.2.
- 4.9.2.2 SISD is the distance required for the driver of a vehicle on the main road to observe a vehicle entering from a side road, decelerate and stop prior to a point of conflict. It is also generally sufficient to enable cars to cross a major road from a side road safely.
- 4.9.2.3 SISD is viewed between two points 1.15m above the road surface. One point is the driver's eye height on the leg with priority and the other represents eye height of a driver in the side road. The driver in the side road is assumed to sit at a distance of 3.0 minimum from the lip of the kerb or edge line projection of the major road.
- 4.9.2.4 SISD allows for a 3.0 second observation time for a driver on the through leg of the intersection to detect the problem ahead for example; car from minor road stalling in through lane, plus Safe Stopping Sight Distance (SSSD).
- 4.9.2.5 SISD is to be provided in accordance with Table 4-11.

Table 4-11 Safe Intersection Sight Distance

Speed Environment	Safe Intersection Sight Distance (m) $R_T = 2.0s^*$
≤ 30 km/hr	50
40 km/hr	73
50 km/hr	97
60 km/hr	123
70 km/hr	151
80 km/hr	181
90 km/hr	214
100 km/hr	285
110 km/hr +	324

*As required on level grade. Correction factors are to be applied on non-level roads in a manner that is consistent with Austroads Guide to Road Design: Part 4A – Unsignalised and Signalised Intersections, see Table 4-12 below.

Table 4-12 Grade corrections to ASD and SISD (cars)

Design speed (major road) (km/h)	Correction (m)							
	Upgrade				Downgrade			
	2%	4%	6%	8%	2%	4%	6%	8%
40	-1	-2	-2	-3	1	2	3	5
50	-1	-3	-4	-5	2	3	5	8
60	-2	-4	-6	-7	2	5	8	11
70	-3	-5	-8	-10	3	7	11	15
80	-4	-7	-10	-13	4	9	14	20
90	-5	-9	-13	-16	5	11	18	25
100	-6	-11	-16	-20	6	14	22	31

4.9.3 Kerb Radii

4.9.3.1 Kerb radii at intersections will be small enough to:

- Provide pedestrian desire lines that are as straight as possible;
- Encourage low speed left turn movements;
- Enable an RTS-14 compliant tactile paver layout to be provided.

4.9.3.2 Tracking paths on public roads will be designed in accordance with RTS 18 New Zealand “on road tracking curves for heavy vehicles” 2007. Kerb radii at intersections will be large enough to accommodate the turning requirements of the design vehicle as follows:

- For turns at intersections where both roads are ‘Classified Roads’ the 18m design semi-trailer with turning path radius of 12.5m, without crossing the centreline of the road being entered;
- For turns between a ‘Classified Road’ and an ‘Unclassified Road’ the 18m design semi-trailer with turning path radius of 12.5m, using any part of the ‘Unclassified Road’ carriageway, and the correct side of the ‘Classified Road’ carriageway;
- For turns at intersections where both roads are ‘Unclassified Roads’ in residential and rural lifestyle zones, the design medium rigid truck with turning path radius of 10m using any part of the carriageway;
- For turns at intersections where both roads are ‘Unclassified Roads’ in Commercial and Industrial zones, the 18m design Semi Trailer with a turning radius of 12.5m using the correct side of the approach road intersection and any part of the carriageway being entered;
- For turns between all public roads, the 85th percentile design car with a minimum turning path radius of 5.8m, using the correct side of the two carriageways;
- Council may require intersections to be designed for a larger vehicle if larger vehicle movements are expected.

- 4.9.3.3 Consideration must always be given to narrowing the width of the carriageway at intersections with kerb extensions to keep pedestrian crossing distances to a minimum and control turning vehicle speeds while allowing for safe passage by cyclists.
- 4.9.3.4 An inside kerb radius of 5m is typically required at kerb extensions to facilitate street cleaning.
- 4.9.3.5 Outside Kerb radii will not be less than 3.0m.

Good Practice

The following matters can provide additional guidance and direction in the design of intersections:

4.9.4 General

- 4.9.4.1 Priority intersections promote movements on higher order roads over lower order roads and that principal will guide the road hierarchy layout.
- 4.9.4.2 The geometry of any road intersection should be designed so that the major route is the through road and has traffic priority. Wherever the roads are of equal classification, traffic volumes and the nature of upstream and downstream intersections will inform the decision of which approach is provided with priority. In some circumstances it may be appropriate to control these intersections with a higher form of control such as a roundabout or traffic signals.
- 4.9.4.3 As priority intersections do not afford any priority to pedestrians, consideration should be given to providing traffic calming or physical crossing aids to improve pedestrian crossing opportunities. This may be achieved through the use of facilities such as kerb extensions, intersection threshold platforms, raised medians and pedestrian islands.

4.9.5 Four Way Intersections

- 4.9.5.1 To improve connectivity in local residential areas Council will consider the use of priority controlled four-way intersection in residential areas where all intersecting roads are 'Unclassified Roads'. The site should have an approach speed environment of no more than 30km/h and where the total number of vehicles passing through the type of intersection not exceeding 1,200 vehicles per day total on all arms at full development. Where higher traffic volumes are anticipated, the intersection should be controlled with a roundabout or the intersection redesigned as a three-leg T-intersection.

4.9.6 Roundabouts

- 4.9.6.1 Roundabouts should be designed to ensure low entry and exit speeds. For safety reasons, it is important that comparable levels of visibility to the right are provided on all approaches to ensure that the entry speed of vehicles on any one approach is not substantially different from other approaches.
- 4.9.6.2 The preferred form of roundabouts at intersections in residential zones incorporates a semi-mountable apron so that through vehicle speeds can be managed whilst still providing for the larger turning requirements of vehicles such as buses, waste collection and emergency vehicles. Conventionally designed roundabouts with comparatively large central islands and approach deflection are generally not appropriate in residential areas. Their capacity advantages are not usually applicable in these lower traffic volume situations.

- 4.9.6.3 When considering installing multi-lane roundabouts, walking and cycling needs to be carefully considered as generally multi-lane roundabouts sever active transport access unless there are specific grade separated facilities for those users.
- 4.9.6.4 Roundabouts can have a negative impact on walking and cycling in higher volume situations as they are inconvenient for pedestrians, deflected from their desire lines, and people waiting to cross one of the arms may not be able to anticipate easily the movement of all motor vehicles on the roundabout, or those entering or leaving it.
- 4.9.6.5 Roundabouts can be designed to benefit pedestrians, as follows:
- a) Splitter islands that incorporate pedestrian island crossing facilities;
 - b) Approaches and departures can be combined with kerb extensions to reduce crossing distances and reduce vehicle speeds;
 - c) By providing pedestrian platforms where the speed environment on an approach is less than 50 km/h.
- 4.9.6.6 Roundabouts can create problems for the vision impaired pedestrians due to confusing auditory signals from approaching and circulating vehicles.
- 4.9.6.7 Roundabouts can be hazardous for cyclists. Drivers entering at relatively high speed may not notice cyclists on the circulatory carriageway, and cyclists travelling past a leg are vulnerable to being hit by vehicles entering or leaving the intersection.

4.9.7 Traffic Signals

- 4.9.7.1 At busy junctions requiring multiple approach lanes and with high numbers of active users, traffic signals are generally preferred over roundabouts.
- 4.9.7.2 The primary factor in proposing use of traffic signals has to do with the availability of safe gaps. If the gaps in the major street flow can safely accommodate entering traffic from side streets for the majority of the time, it is reasonable to assume that traffic signals are not required. However, as vehicle volumes increase, the likelihood of having to provide traffic signals increases.
- 4.9.7.3 Traffic signals are a safe method for active users to cross the road. This is heightened when young, or elderly pedestrians are involved.

4.10 Private Access and Crossings

This section outlines design standards and guidance for access to and from property to roads, including crossings.

Mandatory Requirements

These standards are required in the design of private accesses and crossings:

4.10.1 General

- 4.10.1.1 When designing private accesses, the long-term maintenance costs for the residents must be balanced against the benefits of providing access through a public road.
- 4.10.1.2 The design and construction standards, including drainage for private access must comply with the requirements for an equivalent construction of a public road, including the 50-year design life.
- 4.10.1.3 The footpath and any cycle facility will be continuous across private driveways and private access to ensure priority to footpath and cycle facility users is reinforced.
- 4.10.1.4 The private access will provide for utility services.

4.10.2 Private Access

4.10.2.1 Private access must:

- a) Be designed in accordance with the minimum specifications in Table 4-13;
- b) Only serve up to six residential units or dwellings, commercial or industrial units;
- c) Give access to the lower ranked road in the hierarchy if the site has frontage to more than one road;
- d) Not create a shorter through-route alternative for vehicles, cycles or pedestrians than the adjoining road network;
- e) Intersect with the carriageway at an angle of 90 degrees on classified roads i.e. arterial, principal or collector, and between 75 and 105 degrees on unclassified roads;
- f) Be located at least 1.0m from any side boundary to allow the placement of telecom and power distribution pillars and boxes.
- g) In the case of adjacent property owners in any zone wishing to have a mutual crossing at their shared boundary, the maximum permitted total length of the crossing shall be 8.0m
- h) Mutual crossings at shared boundaries will need specific design and application to Council.

Table 4-13 Private Access and Crossing Width

Zone	Number of Units /Users ¹	Min. Carriage way Width ²	Footpath	Min. Legal Reserve Width	Gradient ³	Surface ⁴	Extension of Carriage way Surface ⁵	Crossing Width at Road Edge/Kerb ⁶
Residential	1	2.75m	-	-	1-in-5 ³	All Weather ⁴	5m ⁵	3.5 - 6m
	2 to 3 ¹	2.75m	-	4.5 ² m	1-in-5 ³	Sealed	Full length	3.5 - 6m
	4 to 6 ¹	2.75m	-	4.5 ² m	1-in-5	Sealed	Full length	3.5 - 6m
Commercial, Central Businesses, Tourist Services etc.	1	4.5m	-	6.0m	1-in-8	Sealed	Full length	5 - 7m
	2-6 ²	4.5m	1.5m	6.5m	1-in-8	Sealed	Full length	5 - 7m
Industrial & Rural Industrial etc.	1	4.0m	-	-	1-in-8	Sealed	Full length	6 - 8m
	2-6	6.0m	-	8.0m	1-in-8	Sealed	Full length	6 - 8m
Rural Lifestyle, Rural Industrial etc.	1	2.75m	-	-	1-in-5 ³	All Weather ⁴	10m	6 - 8m
	2-6	3.0m	-	5.0m	1-in-5 ³	All Weather ⁴	10m	6 - 8m
Rural 1, 2 & 3	1 ¹	2.5m	-	-	1-in-5 ³	All Weather ⁴	10m	6 - 8m
	2-6 ¹	2.5m	-	6.0m	1-in-5 ³	All Weather ⁴	10m	6 - 8m

1 Means any discrete household unit/dwelling or business unit.

2 Where a shared private access in all zones is more than 50m long, a passing bay will be provided (at the start of the Row Tasman District and) at least once every 50m (see 4.10.2.5).

3 Gradients up to 1-in-4.5 can be used on straight lengths over distance of up to 20m. See also 4.10.3 (transition grades).

4 Sealed surface if grade is 1:5 or steeper.

5 Where the proposed private access way is designed with a legal reserve width of 4.5m or less, more detailed design information will be required to satisfy the Council that the specific design provisions will operate satisfactorily. Designers should note that these widths will make turning into and out of properties difficult so careful detailed design will be needed.

6 Refer SD407 for urban vehicle entrance plan and SD409 for rural vehicle entrance plan.

- 4.10.2.2 Where the speed limit is over 60km/h the crossing must comply with:
- a) For a private access serving up to six dwellings (weather or not on the same site) SD409. The grade of the crossing will be more or less level ($\pm 6\%$) for the first 6m from the carriageway;
 - b) For a private access serving more than six dwellings or a rural activity (including sales from a rural property) SD409. The grade of the crossing and the access it joins will be more or less level ($\pm 6\%$) for the first 20m from the carriageway;
 - c) For a private access serving a commercial or industrial activity SD409. The grade of the crossing and the access it joins will be more or less level ($\pm 6\%$) for the first 20m from the carriageway;
- 4.10.2.3 Not more than one crossing is provided per site. Except to facilitate on-site turning and a one-way traffic flow in Commercial and Industrial zones through a site fronting a road with a speed limit of 50 kilometres per hour or less, provided there is at least 7.5 metres between accesses on the same road frontage, and one access is marked "in" and the other "out".
- 4.10.2.4 Where a crossing from a Classified Road gives access to a car parking area containing more than 20 spaces, a queuing area at least 15 metres long will be provided for vehicles entering and leaving the site. The queueing area length is measured from the road boundary of the site to the first point at which a vehicle can turn into a parking space or aisle.
- 4.10.2.5 Passing Bays - any passing bay will be constructed to a minimum width of 5.5m (includes carriageway) and have a minimum length of 6.0m with a 4.0m long taper at each end.
- 4.10.2.6 Vehicle Gates - any gate or door will be hung to open into the site, and is set back sufficiently to ensure that the largest class of vehicle likely to need access to the site on a regular, frequent or predictable basis can be stopped off the road carriageway while the gate is being opened or shut.
- 4.10.2.7 Culvert Diameter - the minimum diameter of culverts under driveways where the driveway crosses a road swale drain will be 375mm diameter. Note: this shall also address secondary flow paths so that they are contained within the swale.
- 4.10.2.8 The 'Extension of Carriage way Surface' shown in Table 4-13 is measured from road edge and shall be concrete or match the footpath surface where one exists except:
- a) In industrial zones when it will be concrete;
 - b) Where a chip seal footpath exists in non-industrial zones when it will be asphaltic concrete.
- 4.10.2.9 The berm or shoulder adjacent to a private access with more than one user will be designed to incorporate collection areas for waste and recycling wheelie bins without blocking the footpath. The collection area will be 1.0m² for each property accessed from the private access.

4.10.3 Gradients

Critical aspects of private access design and crossings in relation to gradient are set out in Table 4-13 with details on transitions shown in SD406 to SD409 and Figure 4-119.

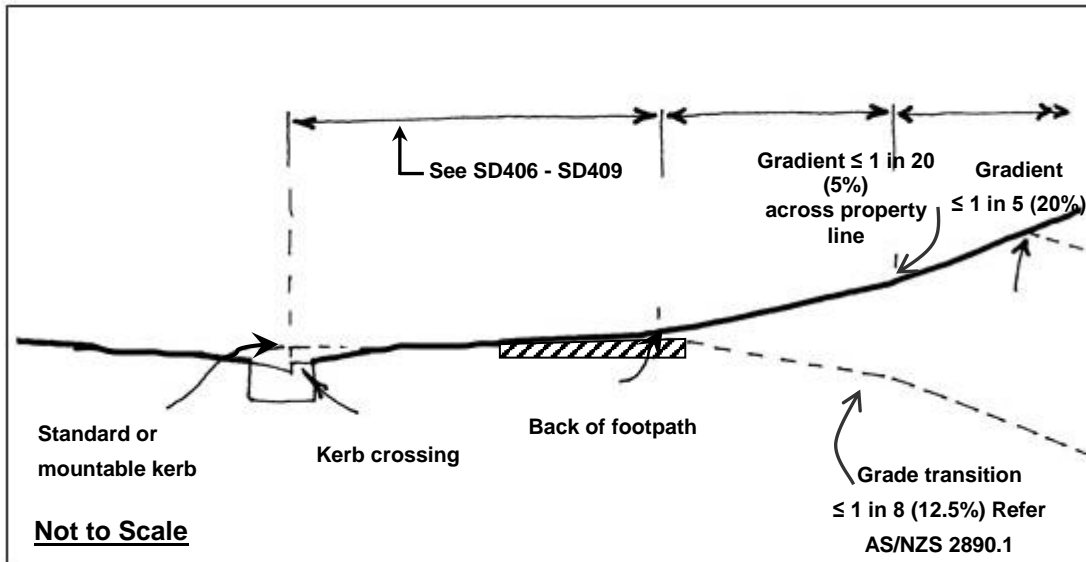

Figure 4-9 vehicle entrance grade transitions Grade changes are required to ensure vehicles will not scrape their undersides. Grade transitions of 2.0m long are required whenever the ramp grade changes by more than 12.5%. Refer to 'AS/NZS 2890.1:2004 Parking facilities – Part 1: Off-street car parking' for detailed design guidance.

- 4.10.3.1 Gradients of an access that crosses a footpath shall generally be as shown in SD's 406, and 407.
- 4.10.3.2 Except as specifically provided for in the standards of this sub-section, the maximum gradient of an access ramp for the first 6m from the property boundary line will be 1-in-20 (5%). Where the following conditions are met, the grade can be increased to 1-in-8 (12.5%) for the first 6m:
- The ramp is a downgrade for traffic leaving the property; and
 - The vehicular access is to an 'Unclassified Road'.
- 4.10.3.3 On roads where the footpath is located against or close to the kerb and where the target speed environment is 40km/h or lower, vehicle crossings will be designed with a mountable kerb.

4.10.4 Sight Distances (other than Safe Intersection Site Distance)

- 4.10.4.1 Vehicle Access Sight Distance - sight distance is measured from the motorist's position at the access point (2.5m back from the edge of the carriageway and at a height of 1.1 metres) in both directions along the frontage road. Where the frontage road is one-way or is median divided, the sight distance is only required in the direction of approaching and potentially conflicting traffic movements.

The minimum sight distance that must be available from any vehicle access point along the frontage road is shown in Table 4-14.

Table 4-14 Minimum Sight Distance from Private Vehicle Access Points

Speed Environment *	Minimum Sight Distance (m) $R_T = 2.0\text{sec}$
≤ 30 km/hr	23
40 km/hr	40
50 km/hr	55
60 km/hr	73
70 km/hr	92
80 km/hr	114
90 km/hr	139
100 km/hr	165
110 km/hr +	193

*If the speed environment is not known, the speed environment will be taken as 10km/h above the regulatory speed limit for the purposes of determining minimum sight distances. Based on Austroads Guide to Road Design Part 4A: Approach Sight Distance Table 3.1.

Upgrade/downgrade corrections will be applied in accordance with Austroads Guide to Road Design Part 4A: Table 3.3.

4.10.5 Visibility Splays

4.10.5.1 For all vehicle access points, a minimum visibility splay with the dimensions shown in Figure 4-10 must be provided. Items may be located within the visibility splay provided they do not obstruct visibility to pedestrians. Generally, this means avoiding objects and vegetation with a height of more than 0.9m.

4.10.5.2 For high volume or high safety risk vehicle access points including:

- a) Commercial and Industrial zones;
- b) Vehicle oriented activities¹ with daily volumes in excess of 50 movements;
- c) Where there is a cycle facility² less than 3.0m from the property boundary.

The minimum visibility splay with the dimensions shown in Figure 4-11 must be provided.

If the access is adjacent to a neighbouring property, the access may need to be moved away from the common boundary to comply with sight visibility. The legal easement width may need to be adjusted accordingly.

¹ Vehicle orientated activities includes; Service Stations, Truck Stops, Supermarkets, Malls, Drive In/Drive through, Detail Outlets.

² Cycle facility = cycleway/shared path.

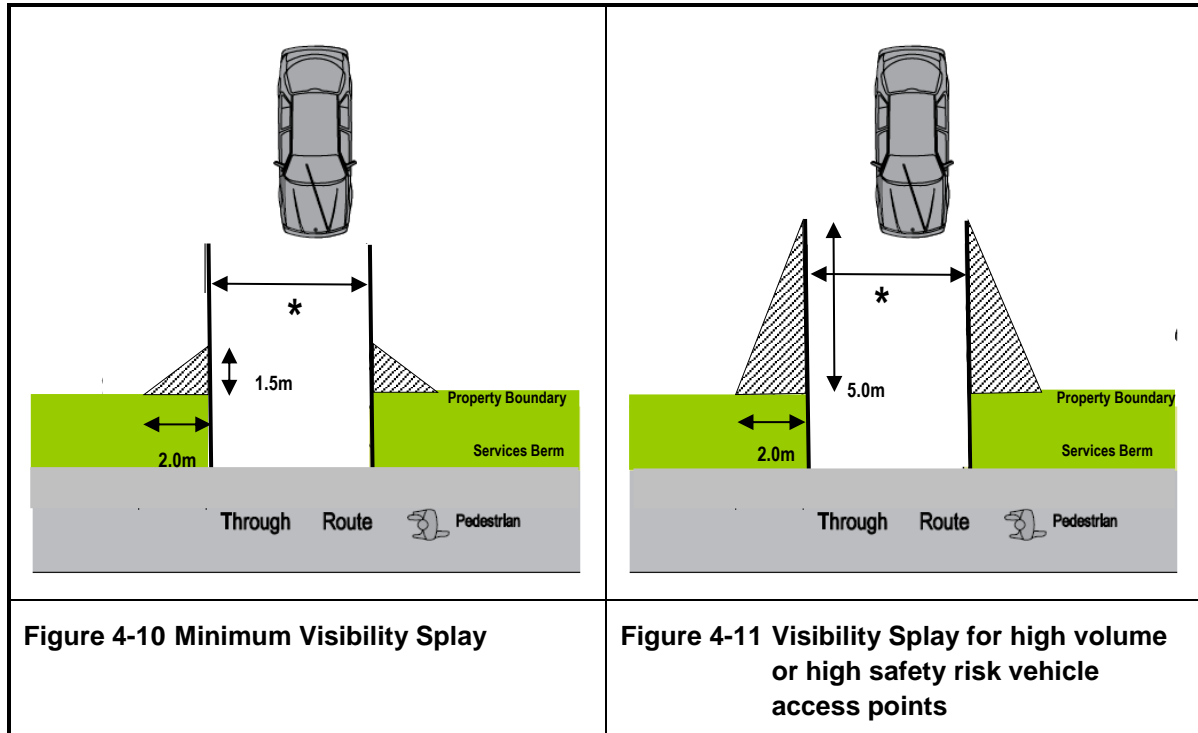

* Carriageway width in accordance with Table 4-13.

4.10.6 Tracking Paths

- 4.10.6.1 Except for a single dwelling that has access from a 'Unclassified Road' with a regulatory speed limit of 50km/h or below; the site will provide manoeuvring space for the largest class of vehicle likely to need access to the site on a regular, frequent or predictable basis, so that a vehicle does not need to reverse to or from the road. The manoeuvring will use no more than three individual movements to allow vehicles to enter and exit a site.
- 4.10.6.2 Tracking paths and turning circles on private land will be provided in accordance with ASNZS 2890.1 "off-street carparking" 2004.
- 4.10.6.3 Vehicle access points must be located so that no part of the access, nor tracking path crosses any part of another site except where there is a right of way or other similar legal easement over those parts of the other site. See Figure 4-12.

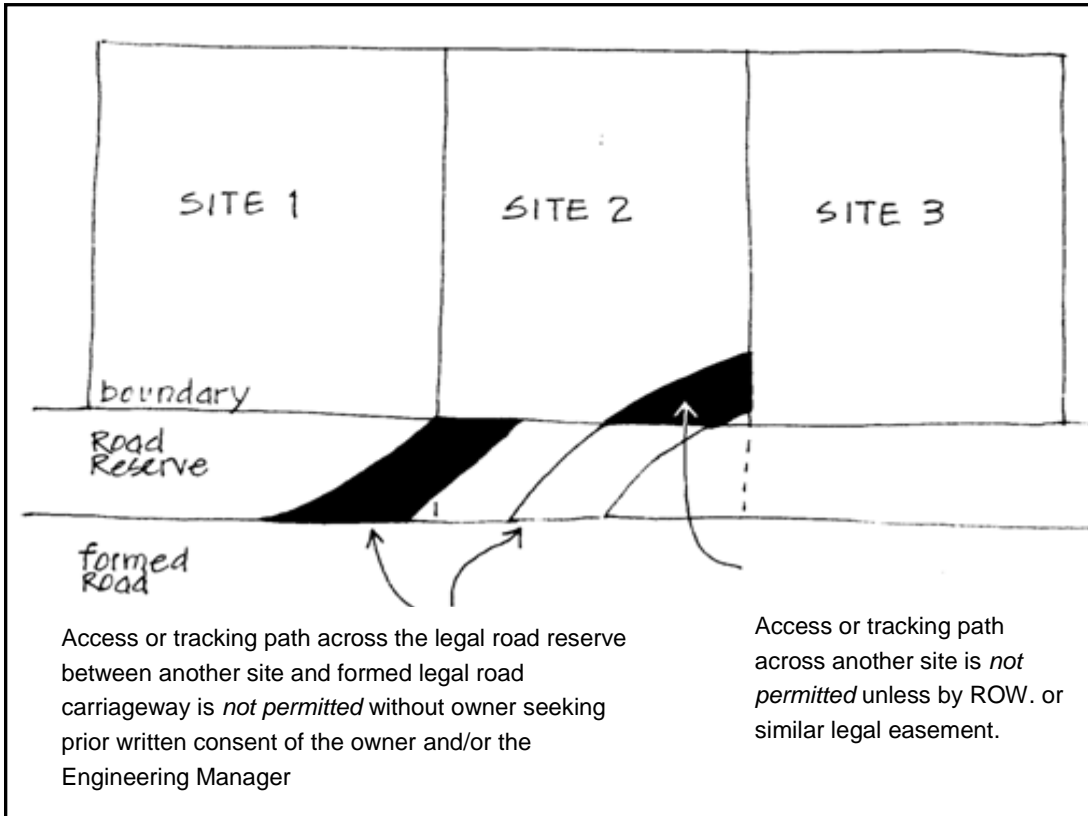

Figure 4-12 Tracking Paths and Access- Steep hillsides only

4.10.7 Minimum distance of a vehicle crossing from intersections

4.10.7.1 No part of a vehicle crossing shall be closer to a road intersection than the distances permitted in Table 4-15 Except when the boundaries of the site do not allow, then a single vehicle crossing may be constructed provided it is located adjoining an internal boundary of the site in the position which most nearly complies with the provisions of on the road ranked lower in the road hierarchy (applies to corner sites).

Table 4-15 Minimum Separation Distance of Vehicle Access from Intersections and private access crossings – metres (see also Fig 4-3)

Access from Frontage Road	Intersecting Road or private access crossing		
	Arterial (m)	Principal/Collector (m)	Unclassified/Private access (m)
Speed Limit up to 50km/h			
Arterial	60	Not Permitted	Not Permitted
Principal/ Collector	50	35	Not Permitted
Unclassified	30	24	10
Speed Limit between 51 and 79km/h			
Arterial	110	Not Permitted	Not Permitted
Principal/ Collector	85	70	Not Permitted
Unclassified	60	50	40

Access from Frontage Road	Intersecting Road or private access crossing		
	Arterial (m)	Principal/Collector (m)	Unclassified/Private access (m)
Speed Limit between 80 and 100km/h			
Arterial	170	Not Permitted	Not Permitted
Principal/ Collector	125	100	Not Permitted
Unclassified	80	70	60

Notes

Distances will be measured along the boundary parallel to the centreline of the road from the kerb or formed edge of the intersecting road/Private access.

- 4.10.7.2 For sites with frontage to a Classified Road; arterial, principal, collector where the speed limit is 80km/h or higher, the minimum spacing between successive accesses on either side of the road will be 200 metres both within sites and between adjacent sites.

Good Practice

The following matters can provide additional guidance and direction in the design of private access and crossing design:

- 4.10.7.3 The number of access points along all roads will be minimised, to avoid:

- Conflict points with people walking and cycling on shared paths and footpaths.
- A reduction in berm that is available for landscaping, street trees and street furniture, thereby reducing the amenity of the road environment;
- A reduction in the amount of on-road parking that is available.

- 4.10.7.4 For residential lots, consideration should be given to the likely position and orientation of future garaging/parking spaces on the lot when deciding on the location of the vehicle access point. This is needed to reduce the likelihood of the access having to be shifted or widened at a later date.

- 4.10.7.5 Continuous vehicle access points may be used within the turning head of a cul-de-sac provided the footpath is offset from the carriageway by at least 1.5m.

- 4.10.7.6 Where 4.10.6.3 cannot be achieved, Council may consider private access over any part of the legal road to which an adjoining property has frontage where the written consent of the owner of the other site and/or the Engineering Manager has been obtained (see Figure 4-12).

- 4.10.7.7 Private access should be designed for good passive surveillance into and along its length.

4.11 Clear Zones

The purpose of a clear zone is to provide space for the driver of a vehicle that leaves the traffic lane to regain control while sustaining minimum damage to the vehicle and its occupants. This section outlines requirements and guidance for the design of them.

Mandatory Requirements

The following standards are required for the design of clear zones within the transportation network:

4.11.1 General

- 4.11.1.1 A clear zone must be measured from the edge of the traffic lane and is the width of roadside available for the driver to undertake corrective action and may include the cycle facility and footpath width.
- 4.11.1.2 Where it is not possible to provide an adequate clear zone, free of non-frangible obstacles for the appropriate distance, a vehicle barrier will be erected.
- 4.11.1.3 Any vehicle barrier within the clear zone, must include the barrier deflection when determining the offset between the edge line and the hazard. Guidance on the design and construction of vehicle barriers will comply with NZTA M23 Notes 'Notes for Road Safety Barrier Systems' (2009).
- 4.11.1.4 Hazards within the clear zone also include vertical drops from features such as drains and culverts. Any vertical drop of more than 1m within the clear zone will be considered to be a hazard. The hazard must be removed or treated to prevent the vehicle going over the drop. A vehicle barrier is likely to be the most common form of treatment.
- 4.11.1.5 To provide this zone, potential non-frangible hazards such as above ground utilities, street furniture, street trees and lighting columns will be located at a distance from the edge of the traffic lane greater than the widths shown in Table 4-16.

Table 4-16 Clear Zone Widths (With Kerb)

Road Hierarchy	Speed Environment		
	≤ 50km/h	70km/h	100km/h
Arterial	2.5	5.4	9
Principal	2.0	5.4	9
Collector	1.5	3.4	9
Sub-Collector	1.0	3.4	6
Local	0.5	3.4	6
Residential Lane	NA	NA	NA

Good Practice

Additional guidance and direction about the design of clear zones is provided below:

4.11.2 General

4.11.2.1 To be regarded as part of the clear zone the areas should be:

- a) Relatively flat, with a maximum side slope of 1-in-3 (cutting) and desirably 1-in-4 (embankment) or flatter; and
- b) Traversable, having slope changes that will keep all wheels of a vehicle in contact with the ground (this assists the vehicle driver to regain control).

4.11.2.2 Only objects which are designed to collapse or break away on impact should be located in the clear zone to ensure minimal damage to a vehicle and its occupants.

4.12 Parking (on street/road)

This section provides standards for the design of parking spaces and car parks (including accessible car parks).

Mandatory Requirements

The following matters are required in the design of parking:

4.12.1 General

Parking is required in accordance with the requirements in Table 4-6 and Table 4-7. If indented bays are used, they will be at least 2.2m wide and no wider than 2.5m.

4.12.1.1 One carpark per two lots is the default on street carpark requirement on 'Unclassified' roads if angled or inset car park bays are provided. Where all the following conditions exist one carpark per three lots can be provided:

- a) Onsite parking requirements are met;
- b) 50% or more of lots are greater than 600m²;
- c) Development is not in a 'Hillside Environment'.

4.12.1.2 Parking bays to be evenly distributed along the road at no greater spacing than 50m.

4.12.1.3 Parking spaces will commence a minimum distance of 6.0m from any side road and no closer than 1.0m to any access.

4.12.1.4 Where parking is metered, restricted or angled individual parking spaces will be marked.

4.12.1.5 Marking is required for all parking start and end points on Arterial, Principal and Collector Roads in Nelson.

4.12.1.6 Where angle parking is used on roads classified as sub-collector roads or higher, clear space must be available for vehicles to manoeuvre to and from spaces completely clear of the live traffic lane.

4.12.1.7 Angle parking is only appropriate on roads where the speed limit is 50km/hr or less.

4.12.1.8 The dimensions of angle parking spaces on street will be in accordance with Parking Standard AS 2890.5.

Good Practice

The following matters provide additional guidance and direction in the design of car parking:

4.12.1.9 Parking should be designed as part of the road design, although it is not always a requirement.

4.12.1.10 On-road parking should be designed to ensure convenient access to frontages and add to the transport amenity.

4.12.1.11 Parking bays may be used to break up the visual impact of on-road parking through separating small groups of parking spaces by kerb extensions, street furniture and planting. The resulting kerb extensions then generally provide more and safer opportunities for pedestrians to cross at mid-block locations and contribute to better overall road environment amenity.

4.12.1.12 An appropriate level of on-road parking may be provided in respect of the following:

- a) The nature of the surrounding land use;
- b) The function and geometry of the road;
- c) The amount of off-road parking provided;
- d) The total amount of parking expected to be generated;
- e) The turnover rate of parking that is anticipated.

4.12.1.13 When designing parking, the following benefits should be considered:

- a) In residential areas, parked vehicles create the perception of a narrower carriageway, which is likely to reduce vehicle speeds;
- b) Parked vehicles can provide a barrier between traffic lanes and the footpath and or cycle facility;
- c) That they provide a common resource, catering for residents, visitors, customers and service vehicles in an efficient manner;
- d) Able to cater for peak demands from various users at different times of the day;
- e) Introduces activity to the road environment.

4.12.1.14 When designing parking, the following matters should be taken into account:

- a) On narrower roads, there may be a tendency for vehicles to park on footpaths restricting pedestrian movement;
- b) On-road parking spaces can visually dominate the road scene and undermine speed objectives, particularly when parking demand is low;
- c) Safety issues may arise for active users if high parking demand reduces the availability of crossing opportunities with adequate visibility;

- d) Safety issues may arise for active users if high parking demand and adequate inter-visibility between the through traffic and the cycle and footpath facilities is not provided at private accessways;
- e) Cars parked on-road can be more vulnerable to opportunistic crime than off-road parking spaces;
- f) Angle parking on Local roads may be designed so that vehicles manoeuvre to and from spaces using the live traffic lane;
- g) Reduction in the volume of stormwater runoff from on street car park areas is encouraged by using permeable paving. The permeable surface must a permanent non-frittering surface. Excess stormwater in the base layers will be controlled so it does not saturate the carriageway layers by either, ensuring the grades and cross falls of the base materials direct excess stormwater away from the carriageway or a subsoil drain intercept is connected to the nearest sump. Acceptable solutions include permeable concrete segmental pavers;
- h) The crossfall of parking bays should be designed to have them drain towards the road unless they have a permeable surface. The width of any dish channel may be included as part of parallel parking width dimensions.

4.13 Public Transport, Footpaths, Public Accessways and Cycle Facilities

This section deals with the design of the transport network for pedestrians, cyclists and public transport.

Mandatory Matters

These standards are required for the design of the transport system for pedestrians, public transportation and cyclists:

4.13.1 Safety from Falling

- 4.13.1.1 Where people could fall 1 metre or more (except in remote locations where the route served presents similar natural hazards) a hand rail will be provided.
- 4.13.1.2 Where a handrail is located adjacent to public roads the handrail will comply with SD420 to SD424.
- 4.13.1.3 In other environments, such as private accesses, the balustrade may comply with the alternative design as in SD419.
- 4.13.1.4 If the designer wishes to erect a balustrade of alternative design to the two above, then full details will be submitted to the Engineering Manager for approval.
- 4.13.1.5 For barrier details of relevant to footpaths refer to Table 4-17 and for cycle facilities refer to Austroads Guide to Road Design Part 6A: Paths for Walking and Cycling - section 5.5.3.

4.13.2 Public Transport

- 4.13.2.1 The development of urban land and design of transport networks must design for the convenient access of public transport.

4.13.3 Footpaths

- 4.13.3.1 The design of footpaths will be in accordance with the requirements of the NZTA Pedestrian Planning and Design Guide.
- 4.13.3.2 The number and width of footpaths are specified in Table 4-6 and Table 4-7 that are to be provided in various planning zones. The widths specified in Table 4-6 and Table 4-7 and are 'Through Route' widths that must be free of all obstructions such as vegetation, light columns, signs, utility furniture, bollards etc.
- 4.13.3.3 Where objects are located adjacent to a footpath a pedestrian will tend to 'shy away' from those objects. In order to ensure 'Through Route' widths are maintained, the minimum footpath width will be increased by 150mm where such an object is present on one side and by 300mm where objects are present on both sides. Refer to Figure 4-13 for widening detail for footpaths of 1.5m through width.
- 4.13.3.4 Where any footpath is located directly against the property boundary it must have a minimum width of 1.65m. Where a footpath is located against a kerb, the width of the footpath excludes the top of the kerb. Refer to Figure 4-13 for widening detail for footpaths of 1.5m through width.

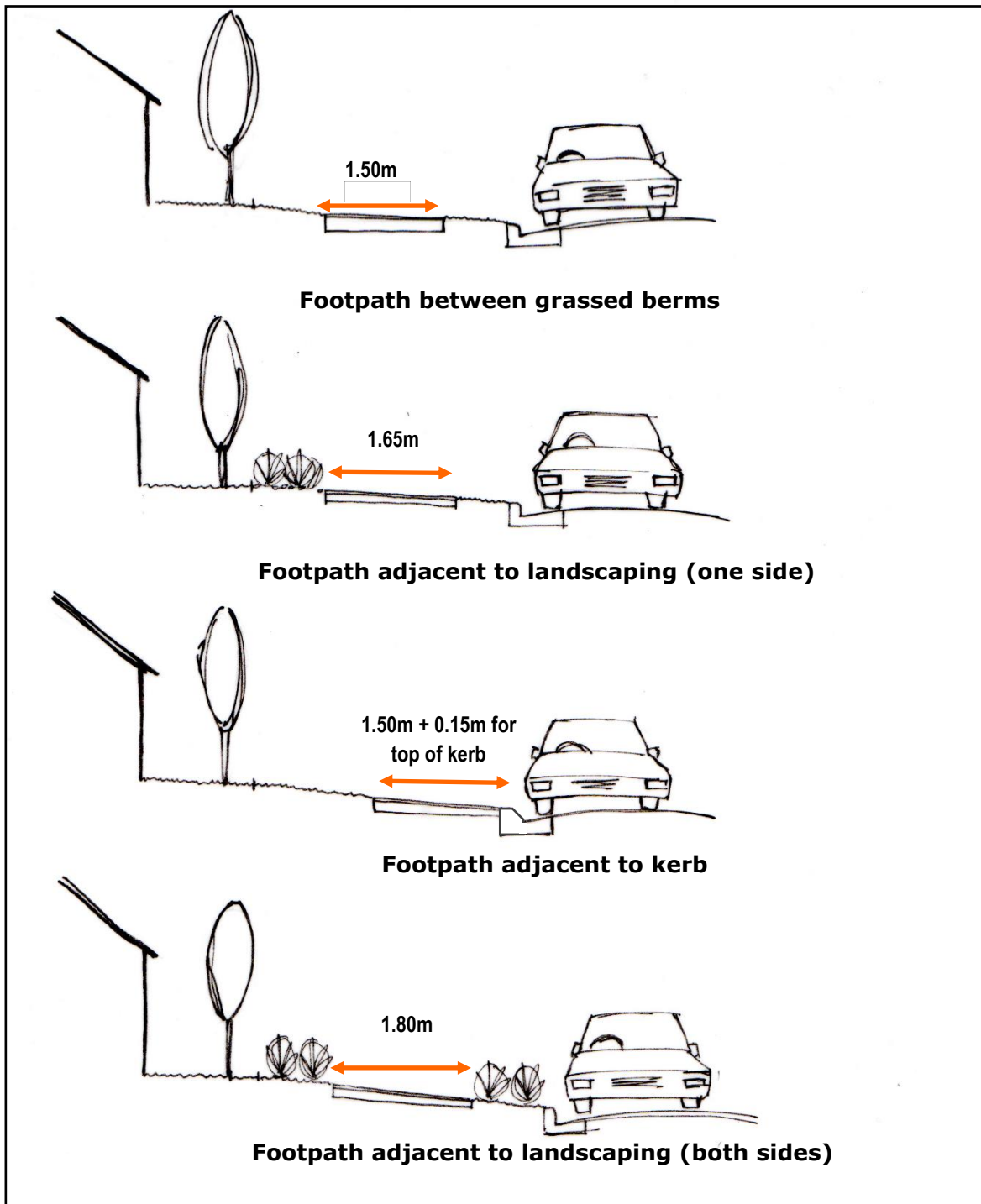

Figure 4-13 Minimum Footpath Widths for Through Width of 1.5m

- 4.13.3.5 In residential areas, footpaths will be separated from the carriageway by a berm, or cycle facility.
- 4.13.3.6 All footpaths in the “Hillside Environments” require specific design to the satisfaction of the Engineering Manager.
- 4.13.3.7 Critical aspects of footpath design specified in this guide that must be adhered to are presented in SD406 and SD407.

Table 4-17 Critical Aspects of Footpath Design

Design Aspect	Design Requirement
Gradient	<p>The mean gradient (change in vertical elevation between the top and bottom of a footpath) on any footpath should not exceed 5%.</p> <p>The maximum gradient (change in vertical elevation measured at 0.6m intervals along a footpath) will not exceed 8% for a continuous distance of 9m.</p> <p>Where one or both are unavoidable, the footpath will be designed as a ramp i.e. provides rest areas.</p>
Crossfall	<p>The maximum crossfall for any footpath is 2%.</p> <p>The crossfall of any footpath must facilitate stormwater flow to on-road drainage systems and not create ponding on the footpath or flow into private property.</p>
Vertical Drop	<p>In situations where there is more than a 1m high drop (i.e. safety from falling), within 1m of the back of a footpath, a handrail will be constructed.</p> <p>The handrail will be located at least 150mm away from the minimum footpath width (refer 4.13.3.3) and no closer than 150mm from the top of the bank. Refer SD420 to SD424.</p>
Overhead Clearance	<p>Footpaths will have a minimum vertical (overhead) clearance of 2.4m</p>

Note

It is acknowledged that in 'Hillside Environments' it may not be practical to achieve the footpath gradients or to design the footpath as a ramp. The gradient requirements are therefore not applicable to new roads in 'Hillside Environments' although careful specific design to the satisfaction of the Engineering Manager is required.

4.13.4 Crossings for Pedestrians and Cyclists

- 4.13.4.1 Having selected the appropriate crossing facility from the guidance in Table 4-17, the facility will be designed in accordance with the NZTA Pedestrian Planning and Design Guide.
- 4.13.4.2 All kerb crossing points must be designed to accommodate all potential users and to minimise the crossing distance for pedestrians. This means ensuring:
- Kerb crossings are provided on both sides of the road;
 - Kerb crossings facilitate crossing perpendicular to the direction of the road;
 - The roadway is as narrow at the crossing point as possible;
 - Crossing facilities meet the same minimum design standards as footpaths with respect to crossfall, overhead clearance and surfacing.
- 4.13.4.3 At intersections, the kerb crossing will be offset from the intersection corner to line-up with the desire line. Where the ramp cannot be on the desire line, or where an intersection allows pedestrians traffic to cross the road at an angle, the kerb crossing ramp will be graded and carried around the quadrant of the kerb corner.

- 4.13.4.4 Kerb crossings will be located so that users have an unobstructed view of traffic approaching from any direction.
- 4.13.4.5 Tactile paving will be installed on all new and upgraded roads at all kerb crossings and other places where the footpath is not separated from the carriageway by an abrupt change in grade (more than 1 in 8) or vertical kerb face (higher than 70mm). Refer SD410.
- 4.13.4.6 Tactile paving will provide a high visual contrast to the adjoining walking surface. 'Safety Yellow' is the required colour standard for tactile paving.
- 4.13.4.7 The layout and installation of tactile paving will be in accordance with the NZTA Road and Traffic Guideline RTS 14 'Guidelines for facilities for blind and vision-impaired pedestrians.

4.13.5 Cycle Facilities

- 4.13.5.1 The design of cycle facilities will be in accordance with the NZTA Cycle Network Guidance and Austroads Guide to Road Design Part 6A – Paths for Walking and Cycling specify the facilities type that are to be provided by zone and hierarchy.
- 4.13.5.2 Where cycle facilities are provided mid-block, they will also be provided on the transition between mid-block and intersection, on the approach to the intersection, at the intersection (storage) and on the departure of the intersection.
- 4.13.5.3 Cycle facilities must be surfaced as per the minimum requirements of Section 4.22 Footpaths.
- 4.13.5.4 Where a cycle facility is provided within a road reserve that has frequent driveways, a buffer between the property boundary and the path must be provided to minimise the risk of a collision between a cyclist on the path and a vehicle exiting from a driveway.
- 4.13.5.5 A separation berm of 1.0m minimum must be provided between the path and carriageway where kerbside parking is permitted to avoid conflict between cyclists and opening doors on the left-hand side of vehicles.
- 4.13.5.6 A minimum lateral clearance of 0.5m (desirably 1.0m) must be provided between the edge of the path and any obstacle, including vegetation, light standards, signs, utility furniture, bollards etc.
- 4.13.5.7 Green coloured surfacing will be used at locations where motorists may be unaware of the likely presence of cyclists, or where motorists are likely to cross over the path of cyclists (for example at intersection transitions or across side streets or high volume private accessways). The green coloured surface will be G26 Apple Green or G31 Verdigris as specified in AS 2700S:1996. The supply and application of the green coloured surface will be in accordance with NZTA P33: 2017.
- 4.13.5.8 Cycle parking will be in accordance with AS 2890.3:2015 Bicycle Parking.

4.13.6 Public Accessways

- 4.13.6.1 The minimum legal reserve width of any public accessway will be 6m including berms and landscaping. Refer to SD427 for detailed design information.

- 4.13.6.2 Public accessways must be designed in accordance with the CPTED Guidelines so that a person using the public accessway can see from one end of the accessway to the other at all times.

Good Practice

The following standards can provide additional guidance on the design of the transport system for pedestrians, cyclists and public transport:

4.13.7 Public Transport

- 4.13.7.1 Residential development that does not have a frontage to a bus route will be provided with convenient walking access to that route.
- 4.13.7.2 Urban bus routes should be selected to take into account a highly accessible residential catchment that provides access to high transport intensity land uses (such as schools, tertiary institutions, hospitals, medical facilities, shopping areas, retirement villages and community facilities), typically using the 'Classified Roads' in residential neighbourhoods. These may extend onto Sub-Collector and Local Roads to maximise the residential catchment.
- 4.13.7.3 Residential development should be designed to maximise the number of sites within a five-minute walk (approximately 360m) of a bus stop.
- 4.13.7.4 An efficient urban bus service may be assisted by:
- a) Locating bus stops conveniently to maximise the walkable catchment while balancing spacing with bus journey times;
 - b) Locating bus stops on the downstream side of intersections;
 - c) Ensuring bus stops and the access routes to them have surveillance from surrounding development; and
 - d) Ensuring traffic management devices are bus friendly.

4.13.8 Footpaths

- 4.13.8.1 When considering the design of walking access, the NZTA 'Pedestrian Planning and Design Guide' and Table 4-18 should be taken into account.
- 4.13.8.2 Primary characteristic of walkable communities are summarised in Table 4-18 and these factors should be considered in the design of the transport network.

Table 4-18 Primary Characteristics of Walkable Communities

Characteristic	Description
Accessible	The places people want to reach, including bus stops, are within an appropriate walking distance.
Comfortable	The walking infrastructure is sufficiently wide, low gradient, smooth and clean. There is frequent shelter from the elements and places to rest.
Connected	The walking network connects people with places they wish to reach, including access to bus stops for longer trips.
Convenient	Walking routes are continuous, unimpeded by obstacles and minimise delay in preference for other road users.
Legible	The walking network is clearly signposted enabling visitors to find their way. Walking facilities are intuitive to use.
Pleasant	Walking spaces are enjoyable and interesting and encourage people to engage in social interaction.
Safe	Road and driveway access points are appropriately designed. The walking surface provides high levels of grip in the wet and is free of trip hazards.
Secure	The walking environment is designed using the principles of CPTED.
Universal	The walking network is suitable for pedestrians of all abilities including mobility and visually impaired persons.

4.13.8.3 The design of footpaths should satisfy a wide range of users and can be achieved by designing footpaths to accommodate the needs of children and disabled people.

4.13.8.4 Notwithstanding the widths specified in Table 4-6 and

4.13.8.5 Table 4-7 the minimum footpath width along any road with frontage to or within 200m to a;

- a) School;
- b) Aged care facility;
- c) Church;
- d) Sports field;
- e) Any high pedestrian generating activity;
- f) Should be widened to 2m minimum.

4.13.8.6 Crossing facilities should be a major consideration when developing pedestrian routes, as pedestrians' perceptions of the walking experience largely focus on difficulties crossing roads and any problems with this can cause delays and create a sense of insecurity.

4.13.8.7 Guidance as set out in Table 4-19 should be taken into account in the selection and design of crossing facilities.

Table 4-19 Crossing Facilities

Crossing Facility	Description	Example Treatments
Physical Aid	These facilities reduce crossing distances and simplify decisions.	Kerb extensions. Pedestrian islands. Raised medians.
Pedestrian Priority	These facilities provide pedestrians with intermittent (time separated) or continuous priority.	Zebra crossings. Kea crossings. Signalised mid-block crossings and intersections.
Spatially Separated	These facilities physically locate the crossing of pedestrians away from general traffic.	Underpasses. Overpasses.

4.13.8.8 Where topography or existing features preclude providing the minimum widths, discuss options with Council.

4.13.8.9 Footpaths may need to abut the kerbs in 'Hillside Environments', where the provision of additional road width to accommodate a berm would result in excessive earthworks.

4.13.8.10 In commercial areas the footpath surface type should extend across the berm area but be broken up by the inclusion of street furniture complementary to the commercial space such as cycle racks, litter bins, amenity planting and seating. Refer section 4.4.7.

4.13.8.11 In other areas, the location of the footpath should be selected by taking into account pedestrian amenity, sun and shade, road lighting, postal deliveries and likely use patterns.

4.13.9 Cycle Facilities

4.13.9.1 A safe, convenient and legible cycle network (cycleway) should be provided for both experienced and less experienced cyclists. The network may comprise both on-road and off-road routes.

4.13.9.2 Linkages for pedestrians and cyclists should create an attractive, friendly, connected, safe and accessible environment. These linkages should ensure that people can move about the community freely in areas where there are few vehicular road linkages.

4.13.9.3 The provision of a 'Shared Use Path' acknowledges that there is additional benefit to the community in allowing other users access to the path and also the impracticability of restricting users other than cyclists.

4.13.9.4 To minimise conflict between various users of a shared use path, the path should provide adequate sight distance between cyclists and other users.

4.13.9.5 A 'Shared Use Path' may be appropriate where:

- a) Demand exists for both a pedestrian path and a bicycle path but where the intensity of use is not expected to be sufficiently great to provide separate facilities;
- b) An existing low use footpath can be modified to provide for cyclists by satisfying legal requirements and as necessary upgrading the surface, width and kerb ramps; and/or
- c) There is an existing road nearby which is available for faster cyclists to use, to limit the extent of user conflict on the shared path.

4.13.9.6 The design of off-road cycleways should take into account the specific requirements of users of the route for example; commuter and/or recreational cycling, level of pedestrian activity etc.

4.13.9.7 Additional recommended guidance (to the NZTA Cycle Network Guidance web based document) on the cycle design of links and intersection can be found in the Austroads Guide to Road Design Part 6A and the [Christchurch City Council Design Guidelines - Design Principles Best Practice Guide](#)

4.13.9.8 Cycle facilities are generally not required on 'Unclassified Roads' because these roads typically have low traffic volumes and are designed to achieve operating speeds that facilitate safe cycling in a mixed traffic environment.

4.13.9.9 The following guidance informs the provision of cycle facilities on lower order roads:

- a) Roads that have a speed environment of 40km/hr or lower and carry less than 5,000 vehicles per day (vpd) do not require specific provision for cyclists;
- b) Roads that have a speed environment of 40-50km/hr and carry more than 2,500 vehicles per day should be designed to accommodate cyclists separately from the traffic lane;
- c) Roads that have a speed environment of 50-60km/hr or more should be designed to accommodate cyclists separately from the traffic lane.

4.13.9.10 Cycle facilities located against the kerb also create issues on rubbish/recycle collection days, as collection is usually placed kerbside. The inclusion of a separating berm allows for this activity to not encroach into the cycle facility space.

4.13.10 Crime Prevention through Environmental Design (CPTED)

4.13.10.1 Ensure pedestrians and cyclists are able to see and be seen clearly in the surrounding area. Avoid sudden corners, blind bends and recessed or entrapment areas along walking/cycling links and ensure that planting does not grow to reduce passive surveillance or provide hiding places for offenders.

4.13.10.2 Choose lighting that illuminates pedestrian and cycling areas as well as roads and ensure it is consistently placed to not conflict with planting or create large areas of shadow. Refer Chapter 9 Telecommunications, Electrical and Street Lighting for details.

4.13.10.3 Provide environments that encourage a high level of social interaction, by designing walking/cycling links that are well patronised.

4.13.11 Intersections and Connectivity

4.13.11.1 Non-vehicle accessways should ensure an attractive and well-connected network that can encourage more people to cycle to local destinations, thus improving their health and reducing reliance on the private motor vehicle as a form of transport.

4.13.11.2 Appropriate intersection treatments can ensure route continuity.

4.14 Road Marking and Signs

This section deals with communication on and around roads, including road marking and signage.

Mandatory Requirements

These standards are required for all road marking and signage:

4.14.1 Road Marking

4.14.1.1 In the Nelson City Council area, the following standards apply:

- a) Centrelines are marked on all 'Classified Roads' and 'Unclassified Roads' that have a speed limit of 60km/hr or above;
- b) Centrelines are marked on sections of roads where insufficient forward visibility is provided between opposing vehicles on narrow carriageways to see each other and stop (refer Table 4-9 for Safe Stopping Sight Distances for various design speeds).
- c) Edge lines are marked on all 'Classified Roads' and on the outside of bends on 'Unclassified Roads' in rural areas.
- d) Edge lines may also be provided on other roads to improve delineation.
- e) No stopping lines are marked within the turning head of a cul-de-sac. However, the use of no stopping lines in other locations must be approved by the Engineering Manager.

4.14.1.2 Tasman District Council requires that all roads are signed and marked in accordance with the Council's Delineation Policy.

4.14.1.3 All new and upgraded roads will provide traffic signs in accordance with The Manual of Traffic Signs and Markings (MOTSAM) and the Traffic Control Devices Rule.

4.14.1.4 All new and upgraded roads will provide road marking in accordance with the NZTA Manual of Traffic Signs and Markings (MOTSAM) – Part II Markings and the Traffic Control Devices Rule.

4.14.1.5 All new edge-lines, centrelines, continuity lines and limit-lines will be reflectorised with Type C glass beads to AS/NZS 2009: 'Glass beads for pavement-marking materials' applied at 275g/m² and 330µm dry film thickness. A second coat is required after six to eight months. A water-based paint may be used for the second coat.

4.14.2 Signs and Gateway Treatments

4.14.2.1 Developers constructing new roads will submit to the Council, at the time of submission of Engineering Plans, a list of suggested road names, with alternatives, including any supporting information for the preferred choices. This includes private ways, walkways and public

accessways. The Designer will be advised of the name(s) that have been approved by the Council in terms of its policy.

- 4.14.2.2 Council will not allow the same names as others used in Tasman or Nelson.
- 4.14.2.3 All walkways and public accessways will use the word 'Way' on the sign.
- 4.14.2.4 Gateway structures and signs are not permitted on Road Reserve. Gateway signs may be located on private land provided they do not restrict visibility and comply with the relevant Resource Management Plan requirements for signs. Maintenance of gateway signs and structures will be a private responsibility.
- 4.14.2.5 All signs must be shown on the Engineering Plans for approval by the Engineering Manager prior to construction.

Good Practice

The following matters can provide additional direction and guidance in relation to road signs and markings:

4.14.3 Road naming

- 4.14.3.1 In Tasman, guidance is provided in the Tasman District Council "Street Naming Policy". Guidance is also provided by AS/NZS 4819.
- 4.14.3.2 Road name frames and posts may be customised to suit the character of the subdivision and matched with street lighting columns and other street furniture, subject to approval by Council.
- 4.14.3.3 Gateway signs and structures need to be carefully considered and designed to ensure they are not interpreted by the public as private areas, where no through access is provided or permitted.
- 4.14.3.4 Consideration must be given to local Maori names for roads that reflect local landmarks, cultural affiliations, historical use or events.

4.15 Streetscaping

This section deals with things like paving, berms, street trees, plant beds, streetlights and street furniture which improve amenity and functionality for a range of users.

Mandatory Requirements

The following requirements relate to streetscaping design and installation:

4.15.1 General

- 4.15.1.1 Grassing, planting including street trees must be installed at least three to six months (depends on the time of year and grass sward and plant establishment) prior to the application for section 224(c) certificate.

4.15.1.2 Replace any trees that die or are damaged during the next growing season within the maintenance/defects period.

4.15.1.3 Watering during the first two summers if required to maintain planting and tree health.

4.15.2 Grassing

4.15.2.1 Berms and the service strip will be a grassed surface or planted in accordance with Section 4.5.3. Topsoil to a firm minimum thickness of 100mm on clay surfaces and 150mm on sandy or gravelly surfaces will then be spread so that a smoothly contoured surface is produced, free of ponding areas. The subgrade will be capable of allowing root penetration and sustaining growth.

4.15.2.2 The final topsoil surface will be flush with the adjacent kerb and footpath and sown with approved grass seed mixtures.

4.15.2.3 The slope of the grass berms from kerb to boundary will generally be 1-in-33 (3%). This slope may vary, but will not be less than 1-in-50 (2%) nor more than 1-in-12 (8%).

4.15.2.4 After topsoiling, the berms will be sown with grass seed that conforms to the following mix proportions:

- a) 1.0kg chewings fescue;
- b) 4.5kg dwarf rye grass;
- c) 0.5kg browntop.

4.15.2.5 The mixture will be sown at a rate of 1kg to 40 square metres area.

4.15.2.6 Prior to the sowing of the grass seed, fertiliser will be spread and mixed with the topsoil. The recommended fertiliser is superphosphate applied at a rate of 30g per square metre.

4.15.2.7 After two months dressing with superphosphate, a dressing with Sulphate of Ammonia applied at a rate of 30g per square metre will be applied.

4.15.3 Planting

4.15.3.1 Planting plans will be provided to the Engineering Manager for checking and approving at the same time as the design engineering plans. Planting of berms and service strips is encouraged where it can meet the requirements in Section 4.15.3.2 below, and is for the purpose of achieving a high amenity low speed environment, enhancing amenity and streetscape in higher density developments and/or accommodating low impact stormwater devices.

4.15.3.2 Plantings will be designed to meet the following requirements:

- a) Street gardens must be located so as not to compromise the integrity and efficient operation of infrastructural services or cause obstruction to transport users;
- b) The number of species used should be minimised and ensure a unified result and species choice in street gardens;
- c) Street gardens should support trees of a reasonable scale to reach 100 years old;
- d) Suitability to environmental conditions for example; ground moisture, wind, etc.;

- e) Pest and disease resistance;
- f) Minimum maintenance requirements.

4.15.4 Street Trees

4.15.4.1 Street tree planting is required and should contribute to the outcomes required in section 4.1.

4.15.4.2 The selection of street tree species will be:

- a) In Nelson from the list on the following link:
<http://nelson.govt.nz/assets/Environment/Downloads/land-development-manual-2010/731314-Street-Tree-Guidelines-19Feb2009.pdf>
- b) In Tasman from the list on the following link:
https://www.tasman.govt.nz/home/SearchForm/?Search=street+tree&action_results=Search

4.15.4.1 All trees will be healthy vigorous and free of any defects that may be detrimental to plant growth and development. Council requires the use of locally sourced native species where appropriate.

4.15.4.2 Street tree plantings will be designed to meet the following requirements:

- a) The mature size of any tree or garden planting will be assessed for each planting location and is to be in scale with the surrounding street environment and the space available and be shown on the planting plan;
- b) Street trees and landscaping species must be selected and located so that growth to maturity or 100 years whichever is the lesser will not impede pedestrian flow, compromise the integrity and efficient operation of infrastructure services, or reduce visibility on curves or at driveways;
- c) Street trees will be provided on service free berms that are at least 1.5m in all directions (or larger as required by Section 4.15.3) or services free paved areas within commercial areas as appropriate;
- d) The positioning of street trees within the road must not create a hazard to vehicles that leave the road. Non-frangible trees, (trees with a trunk of more 100mm diameter measured 400mm above ground surface at maturity) will be positioned so that the clear zones specified in Section 4.11 and the sight lines in Table 4-12 are satisfied;
- e) The minimum planting size of a landscape tree is 1.8m tall at the time of planting and 50mm stem diameter at chest height to minimise vandalism;
- f) No trees or shrubs will be planted within a 2.0m radius of any water valve or hydrant;
- g) The planting hole for the tree will be excavated at least 1m deep and 1.5m square. Good quality soil/compost should be added and the walls of the hole to be loosened to assist root development;
- h) Root barriers will be used within berms along the road kerb edge and footpath edge where appropriate to reduce the likelihood of footpath/road damage. These will extend for an appropriate distance each side of the tree. The distance will depend on the species of tree shown in the approved plan required by 4.15.4.1 above. See SD430;
- i) Tree pit “root directors” and ‘root cells’ are required where trees are within asphalted or hard surfaces. The subgrade below the tree pit must allow roots to grow into the ground surface. It is to be free draining and will not contain any rocks or concrete materials;
- j) Wooden tree staking will be undertaken in accordance with SD430.

4.15.5 Street Furniture

- 4.15.5.1 Street furniture will be standard readily available products intended for the commercial/public space environments, not bespoke or custom designs unless approved by the Engineering Manager. This is to minimise the long-term maintenance cost and make replacement easy in the event of damage.
- 4.15.5.2 Every piece and type of street furniture will be easily detectable (and avoidable) by the vision impaired. This means each street furniture element must:
- Have an element within 150mm of the ground for its entire length parallel to the ground, so that it is detectable by a vision impaired person with a cane;
 - Be placed so that the minimum 'Through Route' widths are maintained. See Section 14.2 of the NZTA Pedestrian Planning and Design Guide;
 - Be placed in a consistent manner to promote the confident movement of vision impaired persons;
 - All street furniture that is located within the clear zone will be collapsible or frangible so as not to create a hazard for vehicles that leave the road.

Good Practice

4.15.6 General

- 4.15.6.1 Opportunities for street trees and landscaping will be taken where possible to improve the visual amenity, recreational quality, biodiversity and ecological links. Clustered planting and a small number of specimen trees in widened berm areas is encouraged over a consistent linear layout.

4.15.7 Planting and Grassing

- 4.15.7.1 Landscaping should be designed to meet the following objectives:
- Provide a sense of separation between the road and the footpath;
 - Integrate with the network of reserves and open space and compliment street tree planting;
 - Maintain adequate visibility for road users;
 - Maintain adequate visibility from residential properties to the road;
 - Provide separation from parking areas;
 - Frame views by emphasising landscape features;
 - Soften hard surfaces;
 - Enhance aesthetic values.
- 4.15.7.2 Berms and service strips should be designed to take into account space for pedestrians to pass, access to and from parked vehicles, a corridor for underground utilities such as water, power and telecommunications, and the planting of street trees and plant beds.

4.15.7.3 Where a material or plantings other than grass is used between the footpath and the property boundary, the treatment should be discussed with Council to ensure the sight line visibility, on-going maintenance and safety issues are addressed.

4.15.7.4 Alternative fertiliser and application rates to suit local conditions may be used subject to prior consultation with the Council.

4.15.7.5 Plant species should be local native plant species, subject to being appropriate to use and conditions of the site.

4.15.8 Street Trees

4.15.8.1 Street trees should enhance and strengthen the existing and intended future character of neighbourhood areas. Tree planting will provide maximum long-term benefit to the public with minimum ongoing maintenance. It must not compromise the safe use of the legal road reserve or affect its structural integrity.

4.15.8.2 Street trees should be established in areas where there the service free berm area can be combined with a buildout for carriageway narrowing, inset parking or similar to give the maximum amount of landscaped area for the tree to thrive and mature.

4.15.8.3 Street trees are preferred on the north side of the street to minimise property shading in winter months, with smaller mature height trees planted on the south side for balance.

4.15.8.4 Trees should not be planted within the rear (services) berm or in road verges less than 1.5 metres in width.

4.15.8.5 Plant species should be local native plant species, subject to being appropriate to use and conditions of the site.

4.15.9 Street Furniture

4.15.9.1 Street furniture design should be sympathetic to the surrounding environment and, where it is intended for use by pedestrians, should be accessible to all users.

4.15.9.2 Seats should be provided near intersection nodes on the footpath and public accessway network to allow rest spots for our aging population and to providing space and opportunity for people to meet and interact.

4.15.9.3 Typical characteristics and conventional locations of common street furniture for new or upgraded streets roads are shown in Table 14.9 of the NZTA Pedestrian Planning and Design Guide.

4.16 Construction General

This section outlines Council's expectations for construction.

Mandatory Matters

4.16.1 General

- 4.16.1.1 The Designer will nominate the method of construction for approval by the Council.
- 4.16.1.2 If the Designer wishes to use a method of construction other than the standard New Zealand Transport Agency specifications then full details of the construction method including programming, plant, etc. will be submitted to the Council for approval.
- 4.16.1.3 The Designer will also submit details of where the nominated alternative construction method has previously been employed together with performance details, acceptance testing results and an independent reference in support of this method.
- 4.16.1.4 If no specific alternative construction method is nominated and approved by the Council, then all works will comply with the New Zealand Transport Agency Specifications.

4.16.2 Road Assessment Maintenance Management (RAMM) Data

- 4.16.2.1 The Designer will submit a completed Road Assessment Maintenance Management (RAMM) Data Sheet (see Appendix A) to the Council for each separate job or section of a continuing job which involves road construction. This will be submitted at the as-built engineering plan stage.

4.16.3 Earthworks

- 4.16.3.1 Land disturbance and earthworks activities are the subject of rules within the NRMP and TRMP. All relevant resource consents and implementation of an approved Erosion and Sediment Control Plan (if needed) will be required before any earthworks or land disturbance can begin.
- 4.16.3.2 NZS 4431: Code of Practice for Earthfill for Residential Development will, except as noted below, provide the standard for fill placement generally.
- 4.16.3.3 In areas of unenclosed filling, where the original ground has a slope steeper than 1-in-2.75 (36%), the original ground surface will be properly prepared before any material is placed against it.
- 4.16.3.4 Any benches will be of sufficient width to accommodate compaction and spreading equipment and will be arranged so as to be adequately drained during the placement of filling material.
- 4.16.3.5 The depth of the layer will be related to the type and model of compaction plant proposed to be used and the type and size of material.
- 4.16.3.6 The Designer will nominate the proposed layer depths and plant and should expect to be required to supply supporting documentation that shows that the proposed compaction method is compatible with the material being used.
- 4.16.3.7 When no information is supplied the following will apply:
 - a) In the carriageway within 500mm of the finished subgrade, the layers will be spread and compacted to a loose depth not exceeding 150mm;

- b) Elsewhere, the layers will be spread and compacted to a loose depth not exceeding 200mm.

- 4.16.3.8 The material will at all times be placed at a moisture content close to the optimum moisture content for the material under consideration. The allowable tolerance will not exceed limits of minus 2% or plus 2%. The Designer will be responsible for supplying a test certificate, quoting optimum moisture contents of the materials encountered on the work.
- 4.16.3.9 The Designer will ensure that for heavy clay silts, sandy clays and gravels the minimum density to be achieved is 95% of the maximum dry density, and for sands the minimum density to be achieved is 100% of the maximum dry density.
- 4.16.3.10 The maximum dry density will be obtained by standard compaction at optimum moisture content as detailed in NZS 4402: Methods of Testing Soils for Civil Engineering Purposes.
- 4.16.3.11 Within the carriageway the criteria for the structural design of pavement (Section 4.17 'Structural Design of Pavement') will take precedence over standards of compaction given in this clause.
- 4.16.3.12 All earthworks and land disturbance activity will cease immediately upon the discovery of cultural heritage artefacts, in accordance with the Heritage New Zealand Pouhere Taonga Act 2014.
- 4.16.3.13 Where there is a known high risk of accidental discovery, a cultural heritage monitor must be present during all excavation works.

4.16.4 Earthworks Routine Testing

- 4.16.4.1 Routine testing will be carried out on earthworks at the rate of one test every one metre depth of filling spaced at 30 metre grid points over the area concerned.
- 4.16.4.2 The results of these tests will be supplied to the Council. All tests prior to and during construction will be carried out by or under the supervision of a Designer experienced in soil compaction techniques. The Council may carry out further tests at any stage if it considers them necessary.
- 4.16.4.3 Where mass earthworks (cutting or filling) are proposed that will extend beyond existing or proposed road boundaries the Council will require the following information, in addition to any requirements under Section 4.16.3:
- a) A plan showing the contours or levels of the existing site, final contour levels, the existing watercourses, together with any available information on the water table and the ground surface of the area concerned, and logs of any bores taken during investigations;
 - b) The positions of boreholes and other geotechnical investigation/testing are to be geo-referenced;
 - c) A pattern of sections showing the extent of cut and fill and a plan showing batter slopes, drainage or culverting;
 - d) The naming of a Designer experienced in soil compaction techniques who will be responsible for supervising and controlling the operations on the site as set out in the specification;
 - e) A specification on the compaction methods and degrees of compaction required, also giving moisture/density test results of the soil to be encountered;

- f) On completion of the earthworks certification from a suitably experienced Geo-Professional will be supplied from the Designer, stating that the requirements of the specification have been carried out and giving details of the test results in accordance with the requirements of the specification (as per Section 10 of NZS 4431 Code of Practice for Earthfill for Residential Development).

Good Practice

The following matters provide additional guidance and direction in respect of Council's expectations for land preparation for road construction.

4.16.5 Land Stability

Where the area of earth fill does not exceed 100m² and the depth does not exceed 600mm maximum, the requirement concerning testing (Section 4.16.4 'Routine Testing') may, at the discretion of the Engineering Manager, not be enforced.

4.16.6 Sedimentation and Erosion Control

All earthworks and land disturbance should be guided by the Sedimentation and Erosion Control Guideline current at the time of development.

4.17 Structural Design of Pavement

This section sets out Council's expectations for the structural design of pavements.

Mandatory Matters

The following matters are required aspects of the structural design of pavements:

4.17.1 General

4.17.1.1 Generally, pavement will be flexible designs. Other types will be subject to Engineering Manager Approval.

4.17.1.2 The pavement design will use the guidance in Austroads Guide to Pavement Technology Part 2: Structural Design (2017).

4.17.1.3 The pavement of all Classified roads and Unclassified roads within Industrial zones will be:

- a) Designed using a mechanistic design method;
- b) Use soaked California Bearing Ratio values in the laboratory of the pavement subgrade in accordance with 6.1 of NZS 4402.6;
- c) Use equivalent standard axle (ESA's) loadings derived from actual and forecast traffic volumes over a 25-year life or 6 x 10⁶ ESA whichever is the greater;
- d) For flexible pavements the minimum layer of M4 AP40 basecourse will be 150mm.

4.17.1.4 The pavement of all Non-Classified roads and private accessways excluding Industrial roads will be:

- a) Designed using a mechanistic design method or empirical chart-based method;

- b) Use soaked California Bearing Ratio values in the laboratory of the pavement subgrade in accordance with 6.1 of NZS 4402.6 or when recommended by a soils specialist the determination of the CBR may be by scalar penetrometer in accordance with clause 3.3.3.2 and figure 3.1 of NZS 4404;

4.17.1.5 Use equivalent standard axle (ESA's) loadings derived from actual and forecast traffic volumes over a 25-year life or the default ESA values in Table 4-20 for each non-classified hierarchy whichever is the greater;

- a) CBR Method - CBR design curves are given on SD402 or Austroad's 'Guide to Pavement Technology Part 2: Pavement Structural Design (2017)' the Structural Design of Road Pavements' Figure 8.4;
- b) For flexible road pavements and private ways in commercial and industrial zones the minimum layer of M4 AP40 basecourse will be 200mm but may be reduced to 150mm minimum if a granular sub basecourse layer is used;
- c) For flexible residential and rural private accessway pavements the minimum layer of M4 AP40 basecourse will be 150mm but may be reduced to 100mm minimum if a granular sub basecourse layer is used.

Table 4-20 Design Traffic Loading ESA Minimums

Hierarchy	Zone	Design Traffic Loading in ESA
All Classified	All	6 x 10 ⁶
Sub Collector Residential and Commercial	Residential & Rural Lifestyle	2 x 10 ⁶
	Commercial & Rural	3 x 10 ⁶
	Industrial	4 x 10 ⁶
Access Road	Residential & Rural Lifestyle	9 x 10 ⁵
	Commercial & Rural	1 x 10 ⁶
	Industrial	2 x 10 ⁶
Access Lane	Residential	4 x 10 ⁵

4.17.2 Submission of Test and Design Data

4.17.2.1 The following information will be submitted at the same time that Engineering Drawings are submitted for approval:

- a) All test information obtained to inform the pavement design;
- b) The traffic loading and design calculations including model outputs were appropriate used to determine pavement design.

4.17.3 Basecourse and Sub-basecourse Aggregate

4.17.3.1 Basecourse aggregate used in the construction of pavements will comply with NZTA M4 specification.

4.17.3.2 Sub-basecourse aggregate used in the construction of pavements will comply with SD401.

4.17.4 Acceptance Criteria – Pavement Strength

- 4.17.4.1 For classified roads testing to confirm compaction will be carried out in accordance with TNZ B/02.
- 4.17.4.2 For unclassified roads the Designer will nominate either testing in accordance with TNZ B/02 or Benkleman Beam Testing.
- 4.17.4.3 Testing will be carried out immediately prior to the surfacing of the pavement.
- 4.17.4.4 For Benkleman Beam tests the maximum allowable deflections will comply with Table 4-21.

Table 4-21 Maximum Pavement Deflection

Road Hierarchy	Maximum Deflection (mm)
Arterial Roads	0.8
Principal Roads	1.0
Collector/Sub-Collector/Industrial/Commercial Roads	1.3
Local Road/ Residential Road or Industrial/Commercial Private Way	1.5
Residential Lanes	1.8
Residential Private Ways	2.0

Notes

- 1) One test will be undertaken in every wheel track at 20m intervals but staggered to give tests at 10m spacing in each traffic lane.
- 2) Not more than 5% of the tests will exceed the maximum.
- 3) No single result will exceed the maximum allowable by more than 50%.
- 4) Any area of excessive deflection will not exceed 5.0 square metres.

- 4.17.4.5 Where any areas of the carriageway fail the acceptance testing the Designer will nominate the proposed remedial action for approval by the Council.
- 4.17.4.6 If required by the Council the failed areas will be dug out and clean sub-base and or basecourse compacted in the excavation, and the surface prepared for sealing.
- 4.17.4.7 A further set of tests will be carried out to show that the affected area is up to the required standard.

4.17.5 Acceptance Criteria – Road Profile

- 4.17.5.1 The finished shape of the road will be such that when a straight edge is laid parallel to the centre line of the road or a camber board laid perpendicular to the centre line, the surface will not vary from the straight edge or camber board by more than 10mm in any 3-metre length.

- 4.17.5.2 Prior to sealing, the surface of the road will be clean, reasonably dry, and free of ice, frost, or loose material, tightly compacted and will present a clean mosaic appearance.
- 4.17.5.3 All concrete surfaces, channels, sump surrounds, service boxes, manholes etc will be completed to their final height to fit the finished (sealed) road profile prior to sealing.
- 4.17.5.4 All service boxes and manhole lids will be finished to within 5 to 10mm above the finished (sealed) road profile.

4.17.6 Stabilisation of Construction Courses

- 4.17.6.1 Where the Designer chooses to use stabilising agents on the construction courses to reduce the depths required, they will supply supporting information and test results to demonstrate the type and quantity of stabilising agent is compatible with the type of material and projected traffic loadings.
- 4.17.6.2 The Designer will indicate relevant experience in this field and also supply information on the experience of the proposed contractor.
- 4.17.6.3 This design option will only be permitted after consultation with and approval by the Engineering Manager.
- 4.17.6.4 Where a layer of filter fabric/geotextile is required, due to the ground conditions, to separate the subgrade from construction courses, the design of the filter fabric/geotextile layer will comply with the Notes to the TNZ specification F/7 Geotextiles and the supply and placing will conform to the TNZ specification F/7 Geotextiles.
- 4.17.6.5 The use of geotextiles as a structural element of the pavement design will only be permitted after consultation with and approval by Council.

Good Practice

The following matter provides additional direction and guidance regarding the structural design of the pavement:

4.17.7 General

Alternative design for pavement structure may be allowed to specific limited areas and with the approval of Council.

4.18 Subgrade

This section sets out Council's expectations and standards for the design of and construction of the subgrade.

Mandatory Matters

The following matters are required in the construction of road subgrades:

4.18.1 Subgrade testing

4.18.1.1 Subgrades are inherently variable in nature and reflect the changes in topography, soil type, and drainage conditions that generally occur along an existing or proposed road alignment. The selection of a subgrade design value requires adequate consideration of the degree of variability within a particular project section and the quantity and quality of data on subgrade properties. Subgrade test sites will be:

- a) Spaced at no greater than 120 m for non-rural project/development;
- b) Spaced at no greater than 300 m for rural project/development;
- c) No less than three test sites in any project/development;
- d) Where there is a variation along a project, at least three test sites should be considered for each subgrade, topography and drainage combination.

4.18.2 Subgrade Drainage

4.18.2.1 Subgrade and subsoil drainage will be designed and installed in accordance with TNZ F/2 and F/7 specifications and the accompanying notes.

4.18.2.2 When the road or private accessway is in-cut, a sub-soil drain will be placed below the toe of the batter and connected into the back of the nearest sump downstream.

4.18.2.3 Any permanent wet spot in the subgrade or any area undercut below adjacent sub-soil drains will be connected to the nearest piped stormwater system by another sub-soil drain. Where the drain is located under the carriageway, traffic loading will be taken into consideration for the type of pipe.

4.18.2.4 In areas of high groundwater or where the road pavement design is reliant on the subgrade remaining dry, it may be necessary to install a sub-soil drainage system piped to the nearest stormwater system to prevent excessive moisture getting into to the subgrade.

Good Practice

These matters provide additional guidance and direction in regard to the road subgrade:

4.18.3 Subgrade testing

4.18.3.1 Where the extent of cut or fill for the project is too great to make subgrade testing feasible at the design stage, it may be done on completion of earthworks when subgrade levels have been exposed.

4.18.3.2 Council may require that where subgrade has been tested as part of the design, its condition be reviewed on exposure during construction and pavement thicknesses adjusted accordingly.

4.18.3.3 Council may require the results of such testing and/or review along with consequent adjustments to pavement layer thicknesses before placing of pavement layers commences.

4.19 Carriageway Surfacing

This section outlines Council's expectations for carriageway surfacing.

Mandatory Matters

The following standards are required conditions for carriageway surfacing:

4.19.1 General

4.19.1.1 Surfacing will be in accordance with NZTA P/3 for first coat chip seals, NZTA P/17 for reseals and NZTA M/10 for dense graded asphalts.

4.19.1.2 Two coat chip seals are the minimum requirement for:

- a) Urban and rural carriageways in Residential and Rural Lifestyle zones carrying under 10,000vpd or forecast to carry less than 10,000vpd within the next eight years;
- b) Private ways in residential zones serving more than one unit.

4.19.1.3 In urban areas the wearing surface will be a two coat Grade 4 and Grade 6 chip seal. In rural areas a wearing surface of two coat Grade 3 and Grade 5 chip seal will be applied.

4.19.1.4 Asphaltic Concrete (50mm of DG10 or Mix 15D at the Engineering Managers approval) is the minimum requirement for:

- a) Urban Carriageways in Commercial and Industrial zones;
- b) All high stress locations such as roundabouts, intersections and cul-de-sac turning heads etc;
- c) All urban streets in residential zones carrying 10,000vpd or forecast to carry within eight years more than 10,000vpd;
- d) The road carriageway where a commercial or industrial activity entrance enters/exits on to the existing or new road for the full width of the carriageway and 10m either side of it.

4.19.1.5 Prior to surfacing, the basecourse finish will be such that when swept it presents a tightly consolidated mosaic surface in which the large aggregate is exposed to the surface and is held in place with a matrix of smaller aggregates and the smaller aggregate is held in place by fine material and the matrix does not displace under normal trafficking or sweeping.

4.19.1.6 The standard of sweeping will be sufficient to remove all loose aggregate, dirt, dust, silt and other excess chip seal.

4.19.1.7 Prior to sealing water content testing of the basecourse layer will be carried out in accordance with section 12 of NZTA B/02.

4.19.2 Seal Design

4.19.2.1 The Designer will submit the seal design, for approval by the Council a minimum of seven days prior to any sealing commencing.

4.19.2.2 The submitted designs will include details of:

- a) Sealing binder to be used;
- b) Additives to be used;

- c) Application rates;
- d) Hot spray temperature/range;
- e) Sealing chip test results;
- f) Construction method/plan.

4.19.3 Sealing Binder

4.19.3.1 The materials used will meet the requirements of the relevant clauses of the following NZTA specifications.

- a) TNZ M/1: Roving Bitumens;
- b) M/13: Adhesion Agents.

4.19.3.2 Sealing base binder will be 130/150 penetration grade bitumen or as agreed with the Designer.

4.19.4 Sealing Chip

4.19.4.1 Sealing chip will meet the requirements of NZTA M/6 Specification for Sealing Chip.

4.19.5 Ground Sterilising

4.19.5.1 Immediately prior to any form of surfacing, a strip one metre wide adjacent to each channel will be applied with an approved ground sterilising weed killer at the manufacturer's recommended rate of application.

4.19.6 Application of Sealing Binder

4.19.6.1 All sprayers will meet the requirements of BCA E/2 and have a current E/2 certificate.

4.19.6.2 Spraying operations will be carried out so that private property and street furniture are not affected by overspray.

4.19.6.3 The end of each sealed area will be a straight line at right angles to the road edge. Sealing runs should start and finish on paper and no binder will be allowed to drip onto sections of the roadway that have previously been sealed.

4.19.6.4 An overlap of 50mm will be applied to concrete kerbs, channels and edge restraints.

4.19.7 Application of Chip

4.19.7.1 Chip spreading equipment will be capable of spreading the aggregate evenly, at a controlled rate and in such a way that chip does not tumble on impact with the sprayed surface.

4.19.7.2 All excess chip will be swept from the carriageway and removed from the channels, footpaths, berms and sumps prior to the acceptance of the works by the Council.

4.19.8 Acceptance Criteria

4.19.8.1 The two-coat seal will provide a fully interlocked surface after rolling. Chip loss, bleeding or flushing will not exceed 5% in any one metre by one metre square of the total sealed area during the maintenance period.

4.19.8.2 The developer will ensure that all reseal repairs are carried out to a standard that will not contribute to flushing in the new seal. Any areas of flushing caused by the sealing operations will have all excess bitumen removed so that all acceptance criteria are achieved including any adjacent affected areas.

4.19.9 Dense Graded Asphalt (Asphaltic Concrete)

4.19.9.1 Asphaltic Concrete will be designed and constructed in accordance with NZTA M/10 'Specification for Dense Graded and Stone mastic Asphalts'.

4.19.9.2 For non-classified residential streets dense graded asphalt will comply with NZTA Specification M/10 Table 3.2 'DG7' and will be a minimum compacted thickness of 25mm. The binder will be 80/100-penetration bitumen or as agreed with the Designer.

4.19.9.3 For classified streets and all commercial and industrial zones, dense graded asphalt will comply with NZTA Specification M/10 Table 3.1 DG AC10 and will be a minimum compacted thickness of 50mm. The binder will be 80/100-penetration bitumen or as agreed with the Designer.

4.19.9.4 The dense graded asphalt wearing course will be laid on a Grade 5 membrane chip seal with a tack coat applied to all exposed edges, including any vertical faces on service boxes. If bitumen (not emulsion) is used it will be straight run.

4.19.9.5 All cold asphalt joints are to be Polymer Modified Bitumen (PMB) hot bandaged.

4.19.9.6 The bandage will be at least 100mm wide and 1.5mm thick. Alternative PMB methods will be considered by Council.

Good Practice

These matters provide additional guidance and direction in regard to the carriageway surface:

4.19.10 General

4.19.10.1 Emulsions are encouraged as they keep people safe throughout every stage of handling the product, offer environmental benefits and can be applied in cooler temperatures thus extending the sealing season.

4.19.10.2 Alternative surfacing may be allowed to specific limited areas with the approval of the Council.

4.19.10.3 The seal design and construction plan required in section 4.19.2.2 should be developed based on the guidelines below:

- a) The carriageway will be measured and divided into workable sections to create a 'paving plan'. The size of these sections will be limited to the area of seal that can be completed using the volume of binder on site. (To be complete both coats of two coat seals will be applied) for chip seal and for dense graded asphalt to ensure the paver can operate continuously at constant speeds suited to the rate of supply from a single supply source operated to minimise cold joints;
- b) Individual spray run areas are not to exceed the area that can be chipped at the correct chip spread rate within 5 minutes of being sprayed;

- c) The total rolling requirement is related to the amount of binder sprayed. Contractors are to calculate and document within their construction plan the number of passes required for each section of seal completed;
- d) Where longitudinal joints occur they will be marked out straight and true and be parallel to the centreline. A strip of the first sprayed area will be left unchipped to allow effective jointing with the next pass of the sprayer and the next spray run will overlap to the extent recommended in the Certificate of Compliance for the distributor. No traffic will be allowed to cross uncovered binder;
- e) No longitudinal joints are to be positioned within carriageway vehicle wheel paths;
- f) Where new dense graded asphalt paving abuts an existing surface, that surface should be cut back to form a vertical face for the full depth of the new paving;
- g) Multi and two coat seal longitudinal joints will be positioned to ensure overlaps do not occur in the same location;
- h) Spraying will start and stop within the paper strips;
- i) All binder will be sprayed within the correct temperature range. (see seal design).

4.20 Formation of Residential Lanes, Service Lanes and Private Ways

This section sets out Council's expectations for the formation of residential lanes. Service lanes and private ways.

Mandatory Matters

The following matters are requirements for the formation of residential lanes, service lanes and private ways:

4.20.1 General

- 4.20.1.1 The finished surface will have a crossfall of 1-in-33 (3%) and shaped with a crown or mono crossfall.
- 4.20.1.2 All topsoil and growth will be removed and compacted basecourse and sub basecourse (where required) laid and graded to an even surface.
- 4.20.1.3 The pavement will be designed as detailed in Section 4.17 'Structural Design of Pavement'.
- 4.20.1.4 All formations are to be surfaced in accordance with Section 4.19 'Carriageway Surfacing'.
- 4.20.1.5 Kerb and channelling on private ways on at least one side for the full length of the private way with the crossfall towards it will be required when any of the following are present:
 - a) The private way has a gradient of less than 1-in-60 (1.7%);
 - b) The private way has a length in excess of 20m;
 - c) Three or more potential household units served by the access.
- 4.20.1.6 For residential lanes, kerb and channel will be provided on the footpath side for the full length and the crossfall will fall towards this. A nib kerb, or similar, will be provided on the other side for the full length of the residential lane.

- 4.20.1.7 At intersections of residential lanes, service lanes and private ways with higher order roads a standard access crossing will be constructed (SD406) so that the footpath and kerb runs through. This is to signal to drivers they are entering slow shared space and give pedestrians right of way on the higher order alignment.
- 4.20.1.8 For service lanes, kerb and channel will be provided on both sides for the full length.
- 4.20.1.9 The high side of the formation will be retained by either of the following: kerb and channel, nib kerb
- 4.20.1.10 The kerb and channel will be constructed in accordance with Section 4.21 'Kerb and Channelling'.
- 4.20.1.11 For private ways more than 10m in length or more than 30m² of sealed surface, all stormwater off the formation will be collected and discharged to an approved stormwater system.
- 4.20.1.12 Sumps will be located at the low side of the formation within kerb and channel (or similar) and at the street boundary where falls are towards the carriageway. New sumps will not be permitted within a vehicle access point on the line of the street kerb and channel (or edge of seal where there is no kerb and channel).

Good Practice

These matters provide additional guidance and direction in regard to residential lanes, service lanes and private ways:

4.20.2 General

- 4.20.2.1 Alternative designs and construction of lanes and private ways may be allowed with the approval of the Engineering Manager.

4.21 Kerb and Channelling

This section sets out conditions for design and construction of kerb and channelling.

Mandatory Matters

The following matters are required in the design and construction of kerb and channelling associated with road construction:

4.21.1 General

- 4.21.1.1 Concrete restraint in the form of kerb and channel, nib kerb or mountable kerbing will be provided in all urban areas on both sides of the pavement formation to confine the pavement layers and control stormwater.
- 4.21.1.2 The minimum grade will be 1:250.
- 4.21.1.3 A minimum depth of 100mm of compacted base course will be placed under the kerb and channel. Compaction will be to a minimum of 98% of maximum dry density.

- 4.21.1.4 If unsuitable soil conditions are encountered at the base of kerb and channel excavations, the site will be trenched out below this depth and backfilled with gravel or other approved fill material in layers of a thickness that is compatible with the type of compaction equipment and material being used.
- 4.21.1.5 The concrete will comply with specified requirements of High-Grade Concrete in NZS 3104: 'Specification for concrete production'.
- 4.21.1.6 The profiles will conform to SD404.
- 4.21.1.7 Slip form kerb machines will be used where practical however when not suitable formwork for kerb and channel will be approved dressed timber, steel or aluminium alloy sections adequately oiled or otherwise treated to allow ease of striking without staining of the stripped concrete surface. All formwork will be accurately placed to the lines and levels of the works and will be such as to give the finished kerbs smooth and pleasing lines free of kinks and angles.
- 4.21.1.8 Control joints (for shrinkage control) will be installed at 5.0m intervals. Where the kerb intersects into crossover or undergoes a sharp change in direction the first shrinkage control will be positioned at this point or no further than 2m from the point. The control joint will be provided by a knife-edge cutting while the concrete is still plastic to at least a quarter of the depth of the concrete thickness.
- 4.21.1.9 The contractor must manage early concrete setting to avoid shrinkage cracking occurring between control joints. If the kerb is adjacent to a concrete footpath, then the control joint will coincide with the concrete footpath joints.
- 4.21.1.10 Kerb entries can only be installed with the Engineering Manager's approval.
- 4.21.1.11 Kerbs and channels will be finished such that on straight portions there is no deviation of more than 5mm within the length of a 3m straight edge; nor a deviation of more than 5mm from the line and level.
- 4.21.1.12 Kerbing and channelling be finished with a steel float and any concrete work showing honeycombing or scale in the face is to be removed and replaced.
- 4.21.1.13 All repairs to damaged kerb must be made prior to footpath surfacing.
- 4.21.1.14 Kerb crossings will be designed and constructed in accordance with SD404 and SD405.
- 4.21.1.15 When constructing curves, the use of regular forms to produce a chorded effect will not be accepted.
- 4.21.1.16 Changes of grade will be made with a smooth vertical curve, and horizontal curves will be circular or transition as required by section 4.8.4.

4.21.2 Benchmarks

- 4.21.2.1 The Designer will install Councils' standard benchmark plaques on the top of the kerb. A minimum of one plaque will be installed in each new street, at maximum intervals of 300m.
- 4.21.2.2 Where a plaque is installed to meet the requirement of Land Information NZ (LINZ) and it is installed on top of the kerb, this may be used as the benchmark and the Nelson City Council or Tasman District Council plaque omitted.

4.21.2.3 The proposed location will be shown on the engineering plans. The Designer will establish a reduced level and coordinates on each new benchmark and show this on the as-built plans to two decimal places.

4.21.2.4 Benchmark plaques will be supplied by the Council at no cost to the Designer.

Good Practice

The following matters provide additional guidance and direction regarding kerbing and channelling:

4.21.3 General

4.21.3.1 Horizontal or vertical curves of less than 6m radius will be constructed using special *in situ* formwork.

4.21.3.2 Where a subdivision is staged, the Designer may not be required to install a benchmark in each stage.

4.22 Paths

The following requirements relate to the construction of public accessways, footpaths and cycle facilities.

Mandatory Matters

The following construction standards apply to all paths including footpaths, paths in roads, public accessway links between roads, public accessways linking roads to reserves, paths in reserves and cycle facilities:

4.22.1 General

4.22.1.1 Paths must have a durable non-skid surface.

4.22.1.2 The path surface will be concrete, asphaltic concrete or an alternative surface where specifically approved by the Engineering Manager.

4.22.1.3 Where a footpath is constructed and there is a mountable kerb, or cut down kerb around the head of the cul-de-sac, both will be designed to carry the same vehicle loadings as the carriageway. Refer to 4.21.1.14 Kerb Crossings.

4.22.1.4 The path pavement will be designed in accordance with recognised techniques that include but are not limited to those listed below:

- a) CBR Method (CBR Design curves are given on SD402);
- b) Scala/Dynamic Cone Penetrometer (Design curves are given on SD403).

4.22.1.5 Footpaths and cycle facilities will be continuous across private accesses to ensure priority to footpath and cycle facility users is reinforced as required by section 4.10.1.3.

4.22.2 Concrete Paths

4.22.2.1 The minimum construction is to be 100mm thickness of reinforced 27.5 MPa at 28 days concrete. The surface will be broom finish, or another equivalent non-skid surface.

- 4.22.2.2 Residential entrance slabs will be increased to a minimum of 150mm thick for full width of crossing including side ramps.
- 4.22.2.3 Commercial entrance slabs will have a minimum of 200mm thickness of 27.5 MPa at 28 days concrete and will be reinforced with one layer of 665 WWF placed 50mm from bottom edge of concrete.
- 4.22.2.4 Industrial entrance slabs will have a minimum thickness of 300mm of 27.5 MPa at 28 days concrete and will be reinforced with two layers of 665 WWF reinforcing mesh. The two layers of mesh will be placed 200mm apart with each layer having 50mm cover from the outside surface of the concrete.
- 4.22.2.5 Construction joints are required at 5m intervals, and on both sides of entrance slabs. Refer to SD406 for full details.

4.22.3 Asphaltic Concrete Paths

- 4.22.3.1 The minimum construction is 25mm compacted depth of asphaltic concrete paving complying with NZTA Specification M/10 Table 3.2 'DG7'. The binder will be 80/100-penetration bitumen or as agreed with the Designer over a tack coat prior to paving.
- 4.22.3.2 Path edge restraint will be constructed both sides and will be either:
- a) A ground treated (H4) timber batten 100mm x 25mm minimum pegged along the edges of the path with the top of the batten at finished level and will remain intact after the completion of the work. Refer to SD407; or
 - b) Or concrete kerb, nib or similar in accordance with SD404.
- 4.22.3.3 Joints in the asphalt surfacing will be either saw cut or formed to produce a neat straight line at right angles to the edge of the footpath and a flush smooth finish to the surface of the footpath. Joints will have a tack coat applied.
- 4.22.3.4 Asphaltic Concrete is not permitted for Commercial and Industrial entrances.

4.22.4 Acceptance Criteria

- 4.22.4.1 At no point on the finished basecourse surface will the Clegg Impact Value be less than 25 (after four (4) blows) for footpaths and residential vehicle access points, and 35 (after four (4) blows) for commercial vehicle access points.
- 4.22.4.2 The surface of the finished path will be such that when a 3m long straight edge is placed across the footpath no area deviates from the straight edge by more than 5mm. The edge of the path will not deviate by more than 5mm from the line and levels shown on the approved Engineering Drawings.
- 4.22.4.3 Where adjacent to a kerb, nib or similar the surface of the path will be flush with or no more than 5mm above the finished level of the concrete.
- 4.22.4.4 Note: also Chapter 8 section 8.5.2 and SD803, SD804 and SD805 regarding footpath reinstatement.

Appendix A Form 1 – RAMM Update Sheet

FORM 1—RAMM UPDATE SHEET - NEW OR RECONSTRUCTED ROADS

RECORDED BY _____ (Name) OF _____ (Company) DATE ____/____/____

ROAD NAME _____

(Distance in m) _____ (Circle one or two) (Intersecting road name) _____

START OF SECTION IS _____ m TO THE NORTH / SOUTH / WEST / EAST OF _____ INTERSECTION

END OF SECTION IS _____ m TO THE NORTH / SOUTH / WEST / EAST OF _____ INTERSECTION

SECTION LENGTH _____ m FULL WIDTH

SECTION WIDTH _____ m CONTRACT No. _____

NEW OR EXISTING SUBGRADE																																				
<p>1</p> <p>THE SUBGRADE IS <input checked="" type="checkbox"/> RECONSTRUCTED <input checked="" type="checkbox"/> UNDISTURBED</p> <p>SUBGRADE COLOUR _____</p> <p>SUBGRADE MAXIMUM STONE SIZE _____ mm</p> <p>IF SUBGRADE IS NEW, STATE:</p> <p>SUBGRADE LAYER THICKNESS _____ mm</p> <p>WHETHER SUBGRADE IS NEW OR EXISTING, SHOW THE SOIL TYPE:</p> <table style="width:100%;"> <tr> <th style="text-align: left;">MAJOR PORTION</th> <th style="text-align: left;">SUBORDINATE PORTION</th> </tr> <tr> <td><input checked="" type="checkbox"/> GRAVEL</td> <td><input checked="" type="checkbox"/> CLAYEY</td> </tr> <tr> <td><input type="checkbox"/> SAND</td> <td><input type="checkbox"/> SILTY E.G., SILTY CLAY</td> </tr> <tr> <td><input type="checkbox"/> SILT</td> <td><input type="checkbox"/> SANDY</td> </tr> <tr> <td><input type="checkbox"/> CLAY</td> <td><input type="checkbox"/> GRAVELLY</td> </tr> </table>	MAJOR PORTION	SUBORDINATE PORTION	<input checked="" type="checkbox"/> GRAVEL	<input checked="" type="checkbox"/> CLAYEY	<input type="checkbox"/> SAND	<input type="checkbox"/> SILTY E.G., SILTY CLAY	<input type="checkbox"/> SILT	<input type="checkbox"/> SANDY	<input type="checkbox"/> CLAY	<input type="checkbox"/> GRAVELLY	<p>2 SHOW SOIL STRENGTH:</p> <p>IF SUBGRADE IS MOSTLY CLAY, SILT OR SAND:</p> <table style="width:100%;"> <tr><td><input checked="" type="checkbox"/> Very soft</td><td>Exudes between fingers when squeezed</td></tr> <tr><td><input type="checkbox"/> Soft</td><td>Easily indented by fingers</td></tr> <tr><td><input type="checkbox"/> Firm</td><td>Indented only by strong finger pressure</td></tr> <tr><td><input type="checkbox"/> Stiff</td><td>Indented by thumb pressure</td></tr> <tr><td><input type="checkbox"/> Very stiff</td><td>Indented by thumbnail</td></tr> <tr><td><input type="checkbox"/> Hard</td><td>Difficult to indent by thumbnail</td></tr> </table> <p>OR...</p> <p>IF SUBGRADE IS MOSTLY SAND & GRAVEL:</p> <table style="width:100%;"> <tr><td><input checked="" type="checkbox"/> Loosely packed</td><td>Can remove by hand or easily by shovel</td></tr> <tr><td><input type="checkbox"/> Tightly packed</td><td>Pick required for removal</td></tr> </table> <p>3 SHOW CBR TEST RESULT (IF APPLICABLE):</p> <table style="width:100%;"> <tr><td><input checked="" type="checkbox"/> SOAKED CBR</td><td>CBR</td><td>_____</td></tr> <tr><td><input type="checkbox"/> INSITU CBR</td><td></td><td></td></tr> <tr><td><input type="checkbox"/> STABILISED</td><td></td><td></td></tr> </table>	<input checked="" type="checkbox"/> Very soft	Exudes between fingers when squeezed	<input type="checkbox"/> Soft	Easily indented by fingers	<input type="checkbox"/> Firm	Indented only by strong finger pressure	<input type="checkbox"/> Stiff	Indented by thumb pressure	<input type="checkbox"/> Very stiff	Indented by thumbnail	<input type="checkbox"/> Hard	Difficult to indent by thumbnail	<input checked="" type="checkbox"/> Loosely packed	Can remove by hand or easily by shovel	<input type="checkbox"/> Tightly packed	Pick required for removal	<input checked="" type="checkbox"/> SOAKED CBR	CBR	_____	<input type="checkbox"/> INSITU CBR			<input type="checkbox"/> STABILISED		
MAJOR PORTION	SUBORDINATE PORTION																																			
<input checked="" type="checkbox"/> GRAVEL	<input checked="" type="checkbox"/> CLAYEY																																			
<input type="checkbox"/> SAND	<input type="checkbox"/> SILTY E.G., SILTY CLAY																																			
<input type="checkbox"/> SILT	<input type="checkbox"/> SANDY																																			
<input type="checkbox"/> CLAY	<input type="checkbox"/> GRAVELLY																																			
<input checked="" type="checkbox"/> Very soft	Exudes between fingers when squeezed																																			
<input type="checkbox"/> Soft	Easily indented by fingers																																			
<input type="checkbox"/> Firm	Indented only by strong finger pressure																																			
<input type="checkbox"/> Stiff	Indented by thumb pressure																																			
<input type="checkbox"/> Very stiff	Indented by thumbnail																																			
<input type="checkbox"/> Hard	Difficult to indent by thumbnail																																			
<input checked="" type="checkbox"/> Loosely packed	Can remove by hand or easily by shovel																																			
<input type="checkbox"/> Tightly packed	Pick required for removal																																			
<input checked="" type="checkbox"/> SOAKED CBR	CBR	_____																																		
<input type="checkbox"/> INSITU CBR																																				
<input type="checkbox"/> STABILISED																																				

4 NEW SUBBASE (AP65-AP75)	5 NEW BASECOURSE (AP40)
SUBBASE LAYER THICKNESS _____ mm	BASECOURSE LAYER THICKNESS _____ mm
MAXIMUM STONE SIZE _____ mm	MAXIMUM STONE SIZE _____ mm
SOURCE _____	SOURCE _____
BASECOURSE SPECIFICATION <input checked="" type="checkbox"/> TNZ M/4 <input type="checkbox"/> OTHER (SPECIFY): _____	

6 GEOGRID AND GEOTEXTILE

TYPE _____

7 NEW SURFACE

SURFACING CONTRACTOR _____

<input checked="" type="checkbox"/> CHIPSEAL <input type="checkbox"/> ASPHALT <input type="checkbox"/> FRICTION COURSE <input type="checkbox"/> SLURRY <input type="checkbox"/> CONCRETE <input type="checkbox"/> NOT SEALED <input type="checkbox"/> OTHER	<table border="1" style="width:100%; border-collapse: collapse;"> <thead> <tr> <th>ALD</th> <th>THICKNESS</th> <th>STONE SIZE</th> </tr> </thead> <tbody> <tr> <td>mm</td> <td>mm</td> <td>GRADE</td> </tr> <tr> <td></td> <td>mm</td> <td>mm</td> </tr> <tr> <td></td> <td>mm</td> <td>mm</td> </tr> <tr> <td></td> <td>mm</td> <td></td> </tr> </tbody> </table>	ALD	THICKNESS	STONE SIZE	mm	mm	GRADE		mm	mm		mm	mm		mm		<table style="width:100%;"> <tr> <th>BINDER</th> <th>QUANTITY</th> <th>TYPE</th> </tr> <tr><td>CUTTER</td><td>pph</td><td></td></tr> <tr><td>ADHESION AGENT</td><td>pph</td><td></td></tr> <tr><td>FLUX</td><td>pph</td><td></td></tr> <tr><td>ADDITIVES</td><td>pph</td><td></td></tr> <tr><td>POLYMER</td><td>%</td><td></td></tr> </table> <p>BINDER RESIDUAL APPLICATION RATE _____ l/m²</p>	BINDER	QUANTITY	TYPE	CUTTER	pph		ADHESION AGENT	pph		FLUX	pph		ADDITIVES	pph		POLYMER	%	
ALD	THICKNESS	STONE SIZE																																	
mm	mm	GRADE																																	
	mm	mm																																	
	mm	mm																																	
	mm																																		
BINDER	QUANTITY	TYPE																																	
CUTTER	pph																																		
ADHESION AGENT	pph																																		
FLUX	pph																																		
ADDITIVES	pph																																		
POLYMER	%																																		

NELSON CITY COUNCIL USE ONLY RAD_n867318

Data entered into RAMM? Entered by: _____ Date: _____

GRADING ENVELOPE AP65

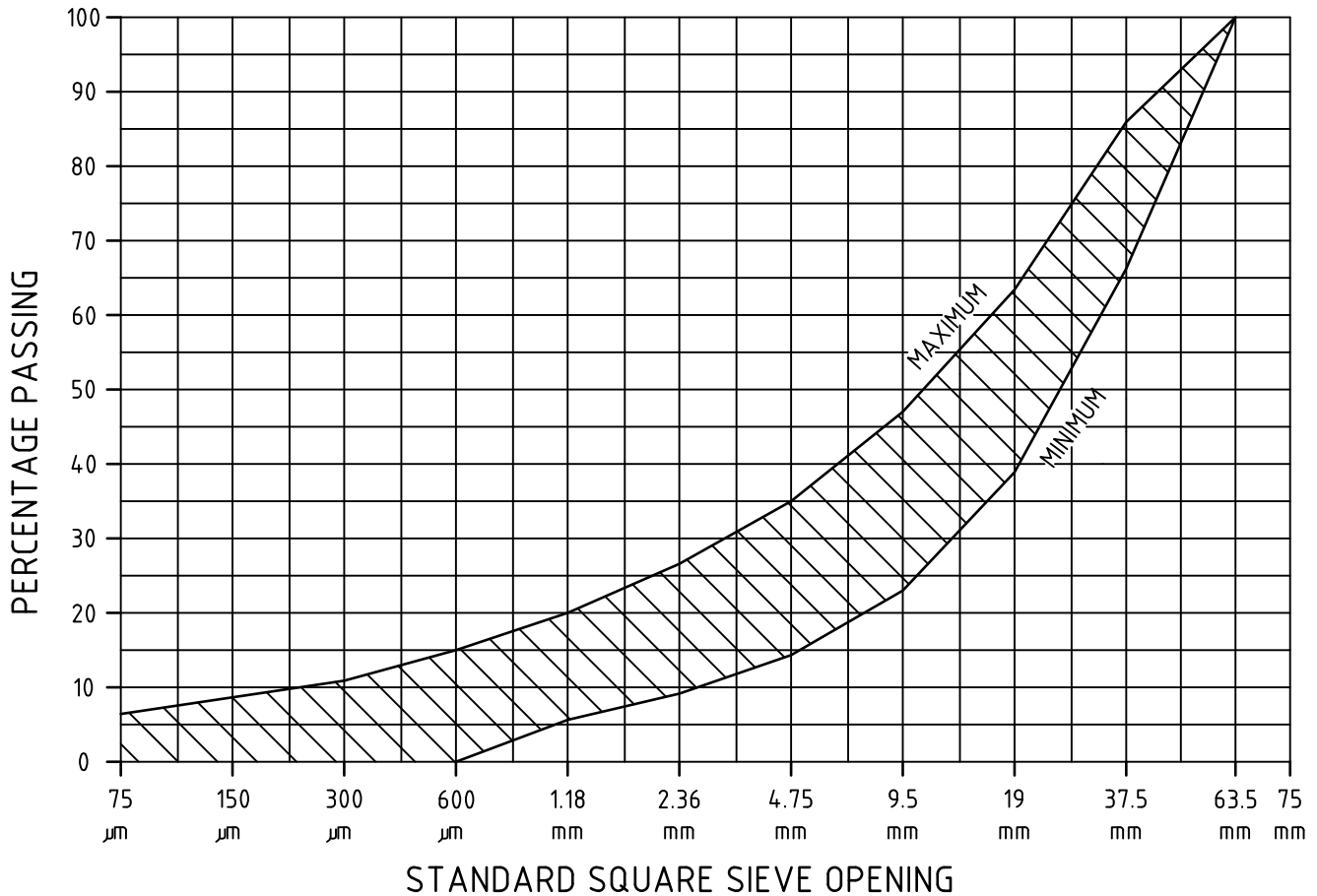

A. PROPORTION OF BROKEN ROCK:

THE PERCENTAGE BY WEIGHT OF MATERIAL IN EACH OF THE FIVE FRACTIONS BETWEEN THE 63.5mm AND 4.75mm SIEVES HAVING TWO OR MORE BROKEN FACES SHALL NOT BE LESS THAN 70%

B. CRUSHING RESISTANCE:

THE CRUSHING RESISTANCE SHALL NOT BE LESS THAN 110kN



C. WEATHERING RESISTANCE:

THE AGGREGATE SHALL FALL INTO ONE OF THE FOLLOWING WEATHERING RESISTANCE CATEGORIES:- AA AB AC BA BB CA.

D. SAND EQUIVALENT:

THE SAND EQUIVALENT SHALL NOT BE LESS THAN 25 WHEN THE AGGREGATE IS TESTED ACCORDING TO NZS 4407: 1991.

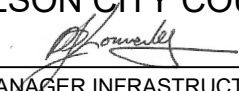

THE CLAY INDEX SHALL BE LESS THAN 4.0, AND PLASTICITY INDEX LESS THAN 5.0.

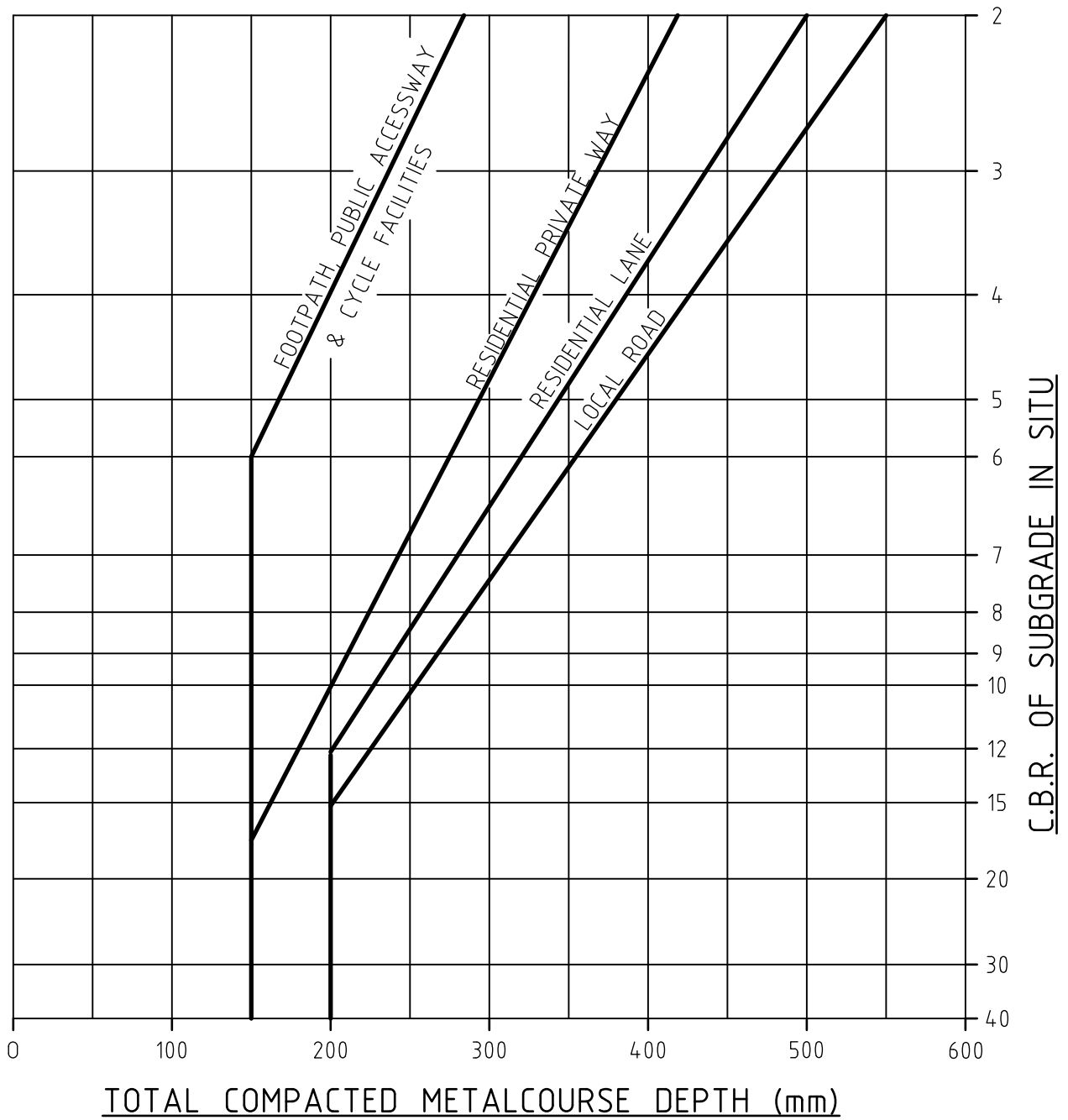
<p>NELSON CITY COUNCIL</p>  <p>GROUP MANAGER INFRASTRUCTURE, NELSON</p>		<p>65mm SUB-BASECOURSE AGGREGATE</p>	
<p>TASMAN DISTRICT COUNCIL</p>  <p>ENGINEERING SERVICES MANAGER, TASMAN</p>		<p>DATE</p> <p>01/07/19</p>	<p>NELSON - TASMAN LAND DEVELOPMENT MANUAL</p>
			<p>401</p>



NOTE:

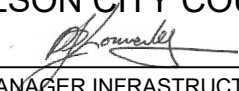

MINIMUM M/4 AP40 BASECOURSE LAYER REQUIRED IS 100mm FOR CONCRETE FOOTPATHS, 150mm FOR ASPHALTIC CONCRETE FOOTPATHS & RESIDENTIAL PRIVATE WAY's, 200mm FOR ROADS & COMMERCIAL/INDUSTRIAL PRIVATE WAY's

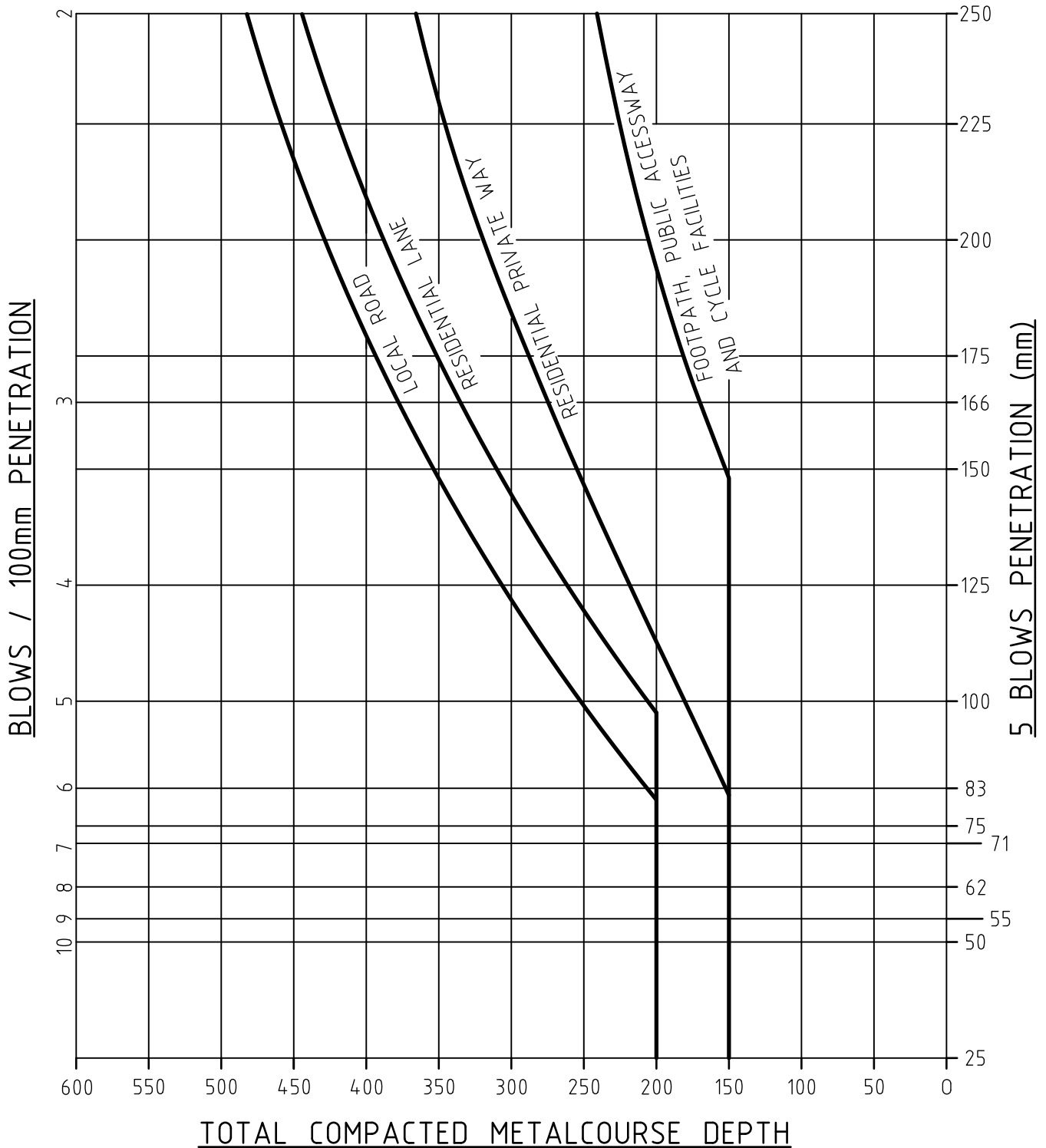
NELSON CITY COUNCIL  GROUP MANAGER INFRASTRUCTURE, NELSON		DESIGN GRAPH FOR LIGHT FLEXIBLE PAVEMENTS CBR METHOD	
TASMAN DISTRICT COUNCIL  ENGINEERING SERVICES MANAGER, TASMAN		DATE 01/07/19	NELSON - TASMAN LAND DEVELOPMENT MANUAL
			402

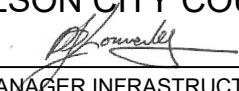

NOTE:

MINIMUM M/4 AP40 BASECOURSE LAYER REQUIRED IS 100mm FOR CONCRETE FOOTPATHS, 150mm FOR ASPHALTIC CONCRETE FOOTPATHS & RESIDENTIAL PRIVATE WAY'S, 200mm FOR ROADS & COMMERCIAL/INDUSTRIAL PRIVATE WAY'S

<p>NELSON CITY COUNCIL</p>  <p>GROUP MANAGER INFRASTRUCTURE, NELSON</p>		<p>DESIGN GRAPH FOR LIGHT FLEXIBLE PAVEMENTS</p> <p>SCALA DYNAMIC CONE PENETROMETER</p>	
<p>TASMAN DISTRICT COUNCIL</p>  <p>ENGINEERING SERVICES MANAGER, TASMAN</p>		<p>DATE</p> <p>01/07/19</p>	<p>NELSON - TASMAN</p> <p>LAND DEVELOPMENT MANUAL</p>
			<p>403</p>

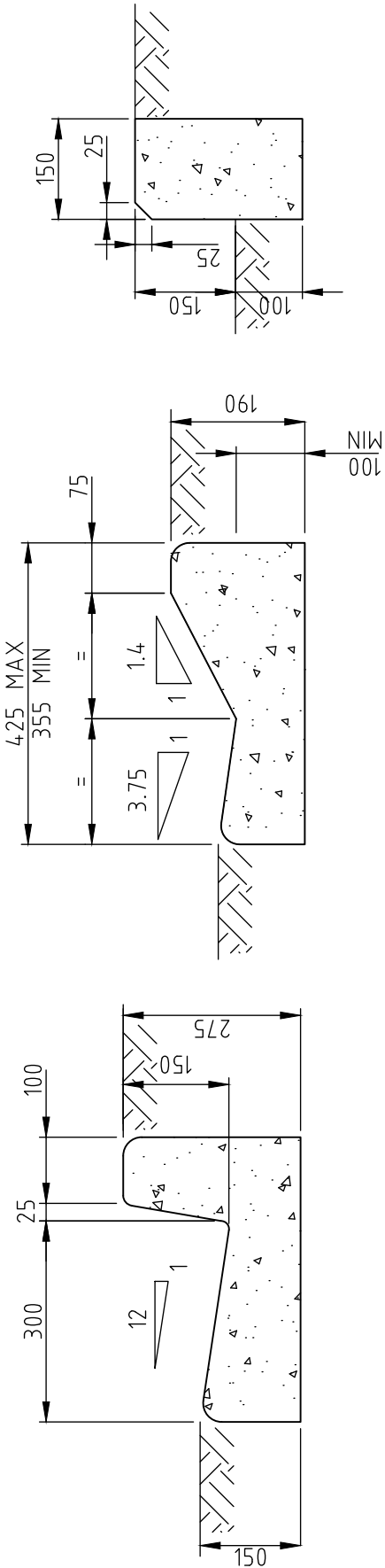

KERB & CHANNEL

MOUNTABLE KERB & CHANNEL

UNMOUNTABLE KERB

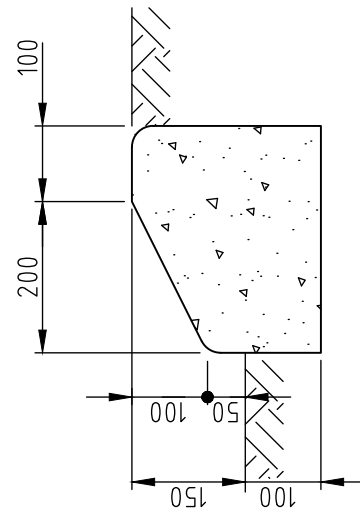

MOUNTABLE KERB

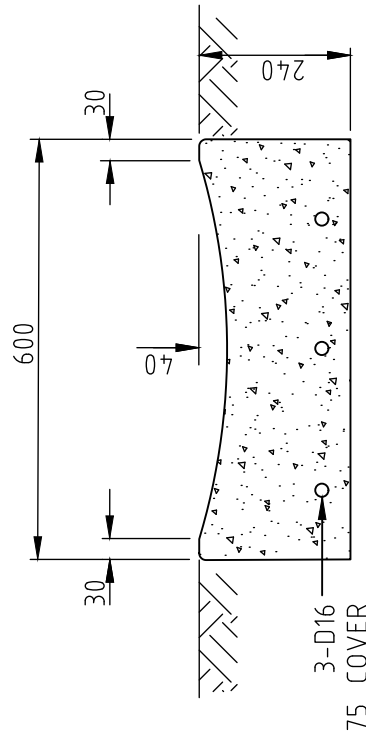

DISH CHANNEL

NOTE:

27.5 MPa CONCRETE
AT 28 DAYS MINIMUM

NELSON CITY COUNCIL
[Signature]
GROUP MANAGER INFRASTRUCTURE, NELSON

STANDARD KERB & CHANNEL PROFILES

TASMAN DISTRICT COUNCIL
[Signature]
ENGINEERING SERVICES MANAGER, TASMAN

DATE
01/07/19

NELSON - TASMAN
LAND DEVELOPMENT MANUAL

404

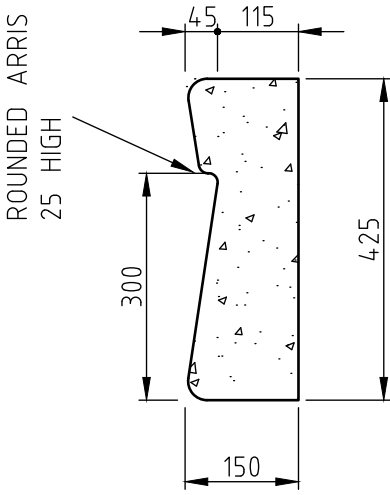

STANDARD RESIDENTIAL CROSSING

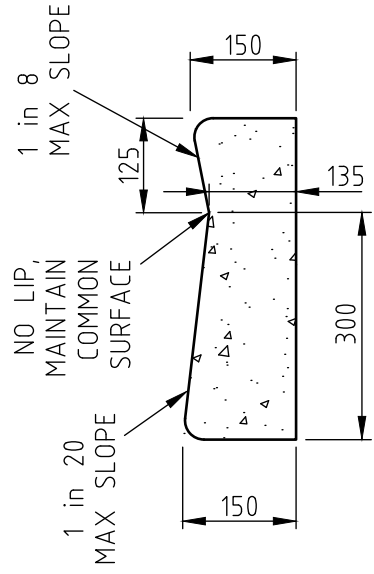
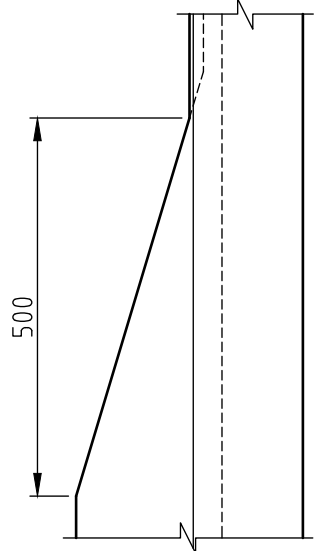

PRAM CROSSING

NOTE:

27.5 MPa CONCRETE AT 28 DAYS MINIMUM

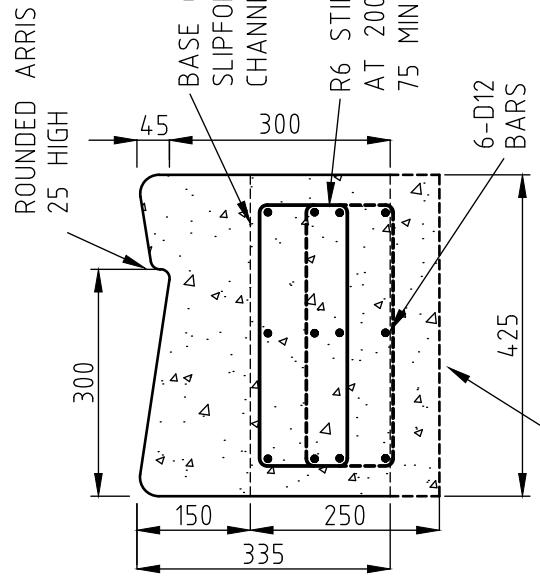

DEEPEN BASE AND LOWER REINFORCING WHERE SLIPFORM LAID CHANNEL IS TO BE USED

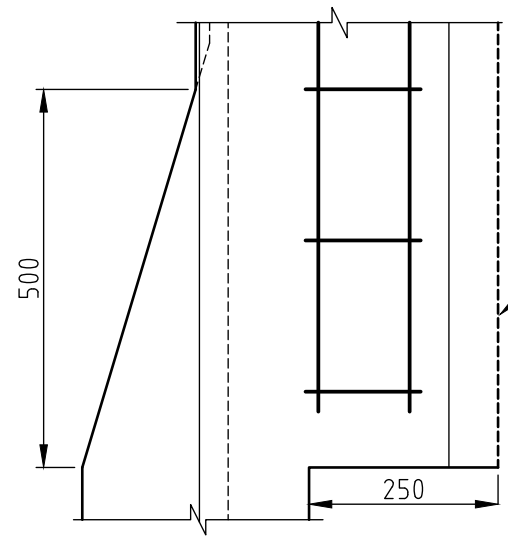

INCREASE DEPTH AT CROSSING
DEEPEENED BASE FOR SLIPFORM LAID CHANNEL

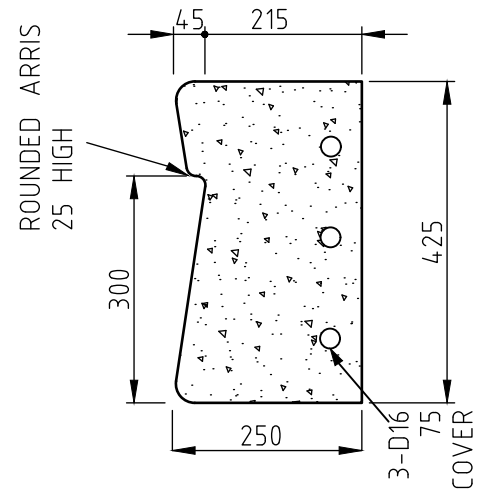

STANDARD COMMERCIAL CROSSING

STANDARD INDUSTRIAL CROSSING

NELSON CITY COUNCIL
[Signature]
GROUP MANAGER INFRASTRUCTURE, NELSON

STANDARD KERB & CHANNEL CROSSINGS

TASMAN DISTRICT COUNCIL
[Signature]
ENGINEERING SERVICES MANAGER, TASMAN

DATE
01/07/19

NELSON - TASMAN
LAND DEVELOPMENT MANUAL

405

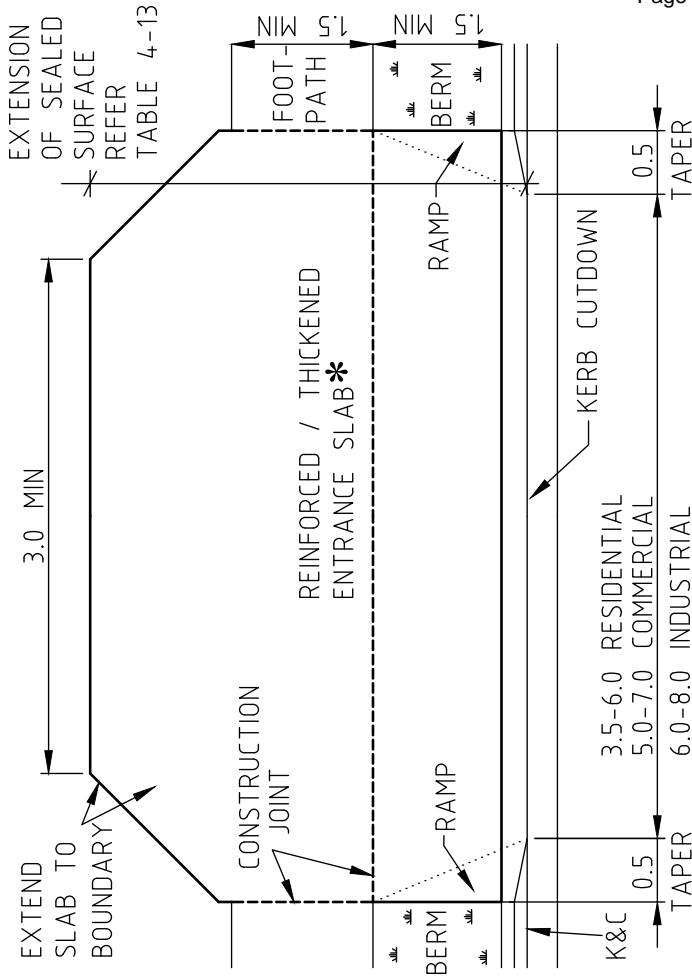

VEHICLE ENTRANCE PLAN

NOTE:

CONCRETE STRENGTH OF 27.5MPa IS EXPECTED AT 28 DAYS OF ALL CONCRETE USED IN COUNCIL'S INFRASTRUCTURE IN THIS LDM.

NB

COMMERCIAL VEHICLE ENTRANCE
200mm DEPTH CONCRETE, 27.5MPa REINFORCED WITH ONE LAYER 665 WWF WITH 75mm COVER FROM UNDERSIDE OF CONCRETE SURFACE.

INDUSTRIAL VEHICLE ENTRANCE
300mm THICK CONCRETE, 27.5MPa WITH 2 LAYERS OF 665 WWF REINFORCING. WWF SHALL HAVE 200mm SEPARATION AND 75mm COVER.

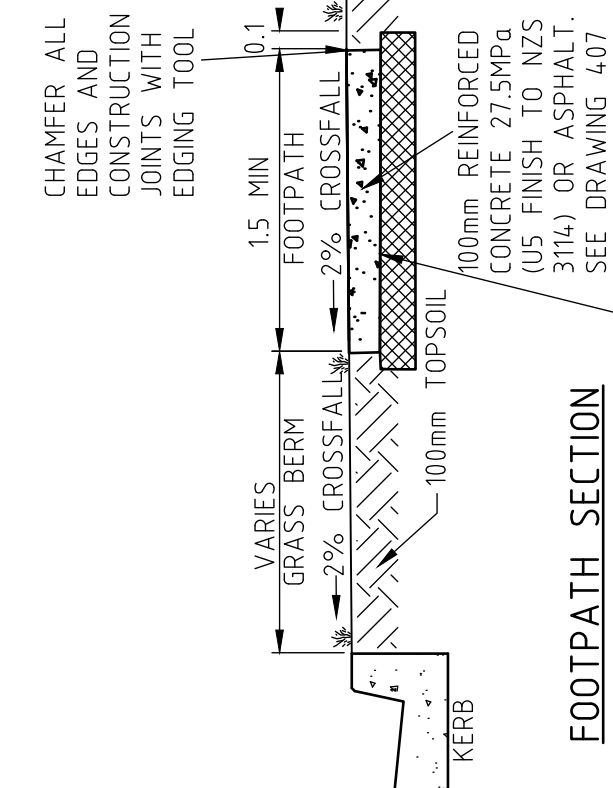

FOOTPATH SECTION

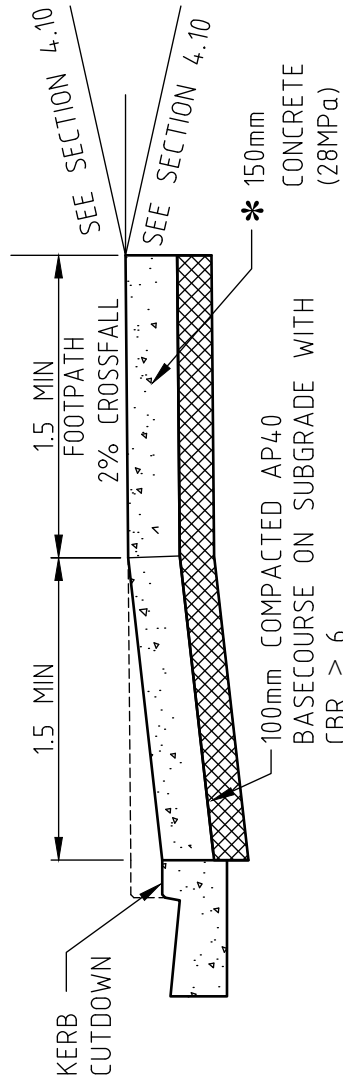

VEHICLE ENTRANCE SECTION

NELSON CITY COUNCIL
[Signature]
GROUP MANAGER INFRASTRUCTURE, NELSON

1.5m WIDE FOOTPATH OFFSET FROM KERB

TASMAN DISTRICT COUNCIL
[Signature]
ENGINEERING SERVICES MANAGER, TASMAN

DATE
01/07/19

NELSON - TASMAN
LAND DEVELOPMENT MANUAL

406

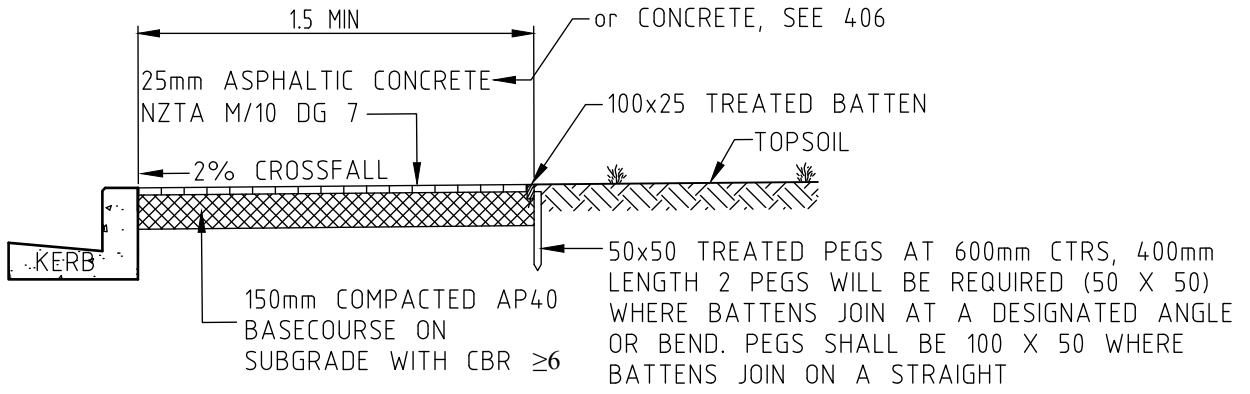

FOOTPATH SECTION

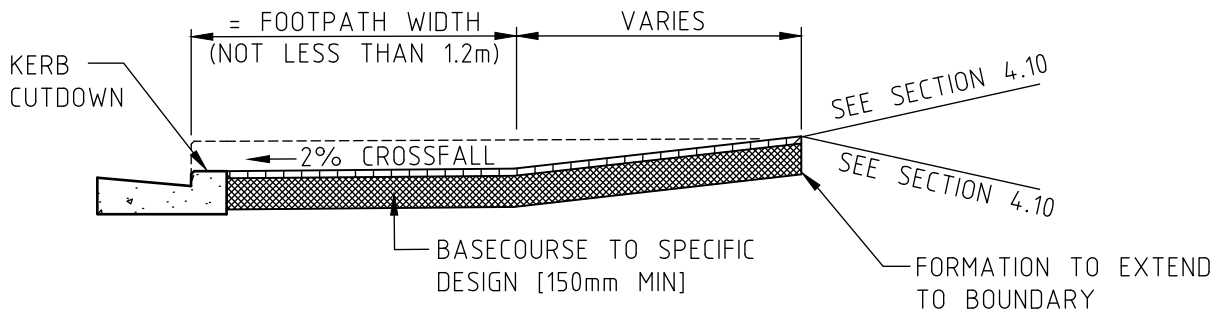

VEHICLE ENTRANCE SECTION

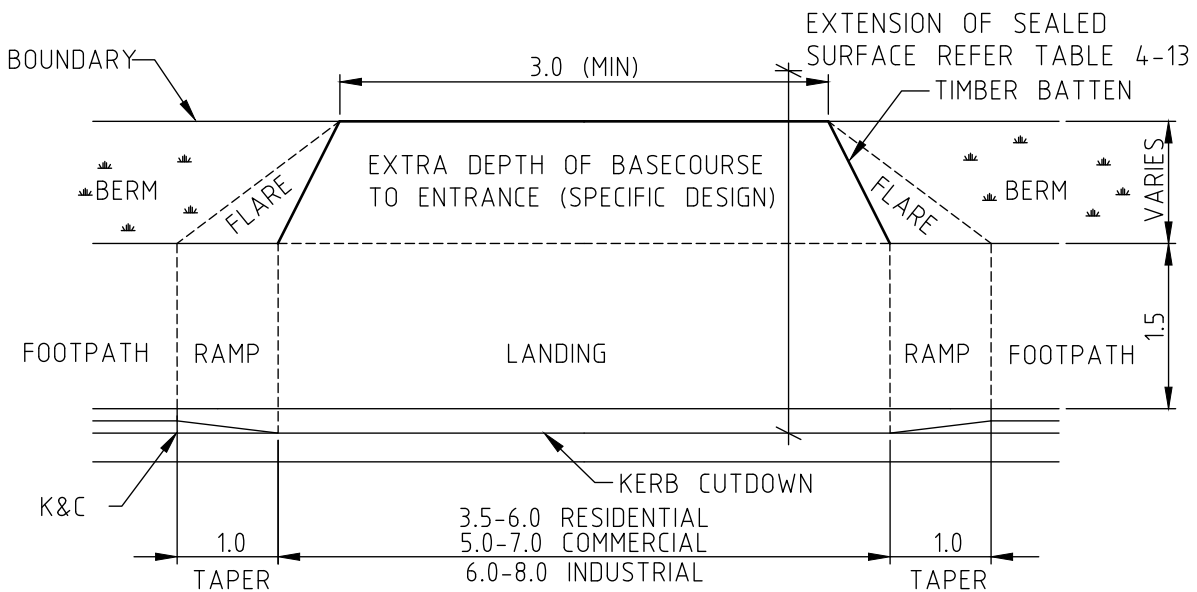

VEHICLE ENTRANCE PLAN

NOTES:

- FOR ROADS WHERE THE VEHICLE DESIGN SPEED IS 40km/hr or LESS, AND THE FOOTPATH IS ADJACENT THE KERB OR BERM LESS THAN 1.5m, THEN FULL HEIGHT MOUNTABLE KERB & CHANNEL SHALL BE USED
- VEHICLE ENTRANCE & FOOTPATH TRANSITION MUST COMPLY WITH FIGURE 15.1 & TABLE 15.2 OF THE LAND TRANSPORT NZ 'PEDESTRIAN PLANNING & DESIGN GUIDE'

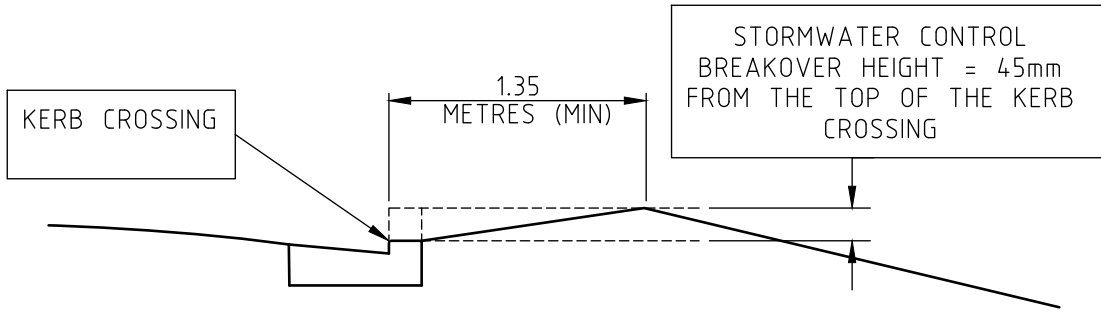

<p>NELSON CITY COUNCIL GROUP MANAGER INFRASTRUCTURE, NELSON</p>	<p>1.5m WIDE FOOTPATH ADJACENT KERB (ONLY WITH COUNCIL APPROVAL)</p>		
<p>TASMAN DISTRICT COUNCIL ENGINEERING SERVICES MANAGER, TASMAN</p>	<p>DATE 01/07/19</p>	<p>NELSON - TASMAN LAND DEVELOPMENT MANUAL</p>	<p>407</p>

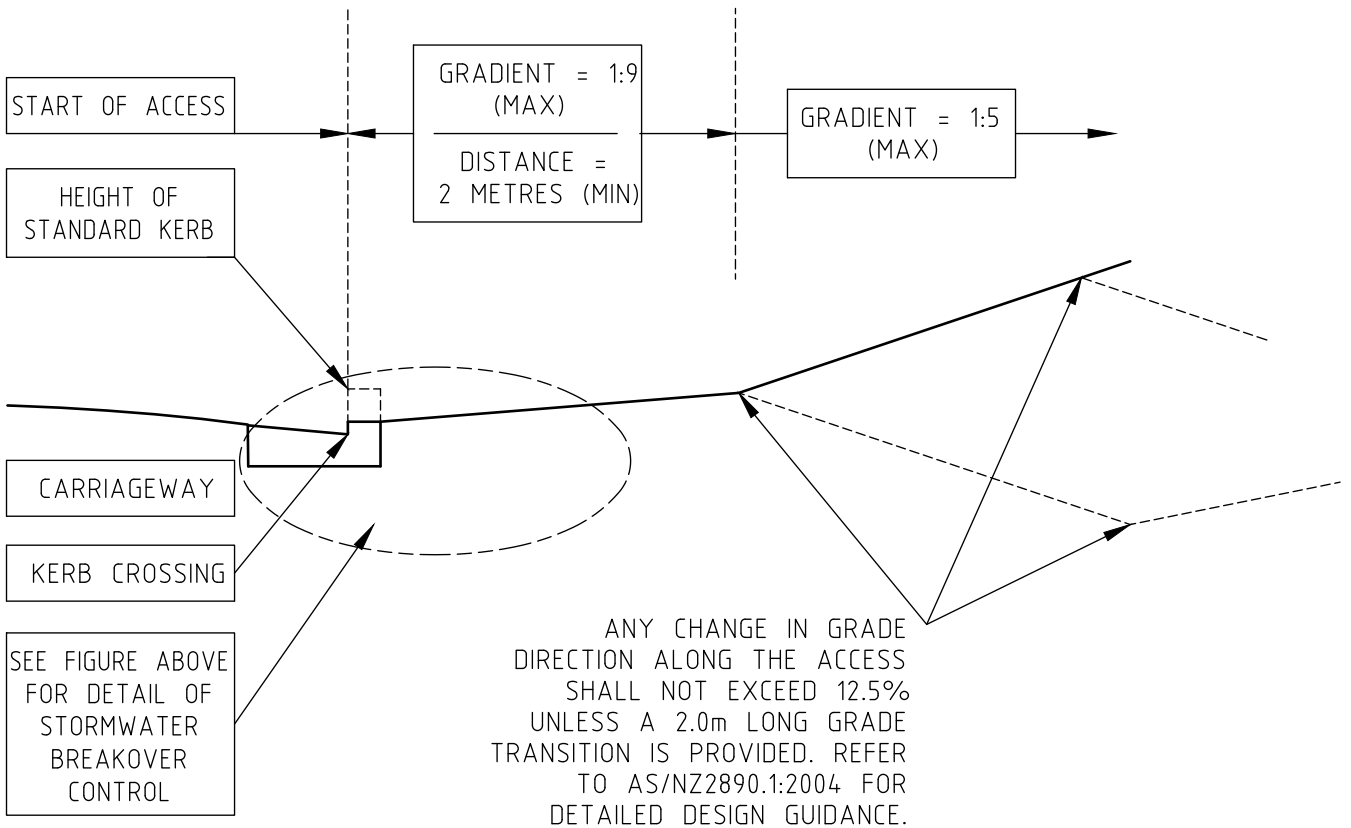

DIMENSIONS OF STORMWATER BREAKOVER CONTROL FOR ACCESSES BELOW THE ROAD

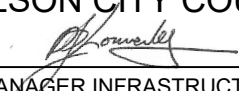

GRADIENT OF ACCESS AND BREAKOVER ANGLES FOR ACCESS TO SITES WHERE THERE IS NO EXISTING OR PROPOSED FOOTPATH

<p>NELSON CITY COUNCIL</p>  <p>GROUP MANAGER INFRASTRUCTURE, NELSON</p>	<p>ACCESS BREAKOVER ANGLES WHERE NO PROPOSED FOOTPATH</p>		
<p>TASMAN DISTRICT COUNCIL</p>  <p>ENGINEERING SERVICES MANAGER, TASMAN</p>	<p>DATE 01/07/19</p>	<p>NELSON - TASMAN LAND DEVELOPMENT MANUAL</p>	<p>408</p>

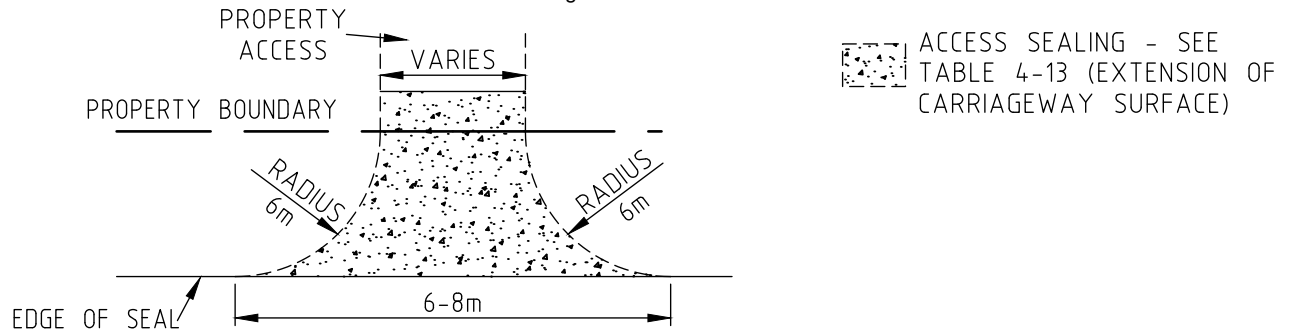

DIAGRAM 1: RURAL VEHICLE CROSSING FOR UP TO SIX DWELLINGS

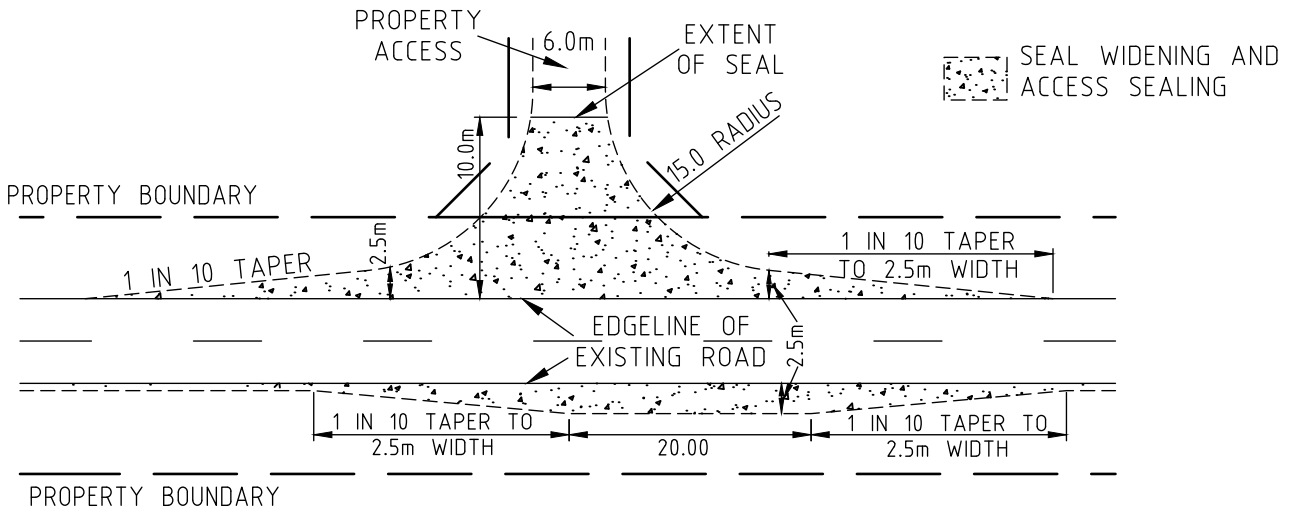

DIAGRAM 2: VEHICLE CROSSING FOR MORE THAN SIX DWELLINGS OR FOR A RURAL ACTIVITY

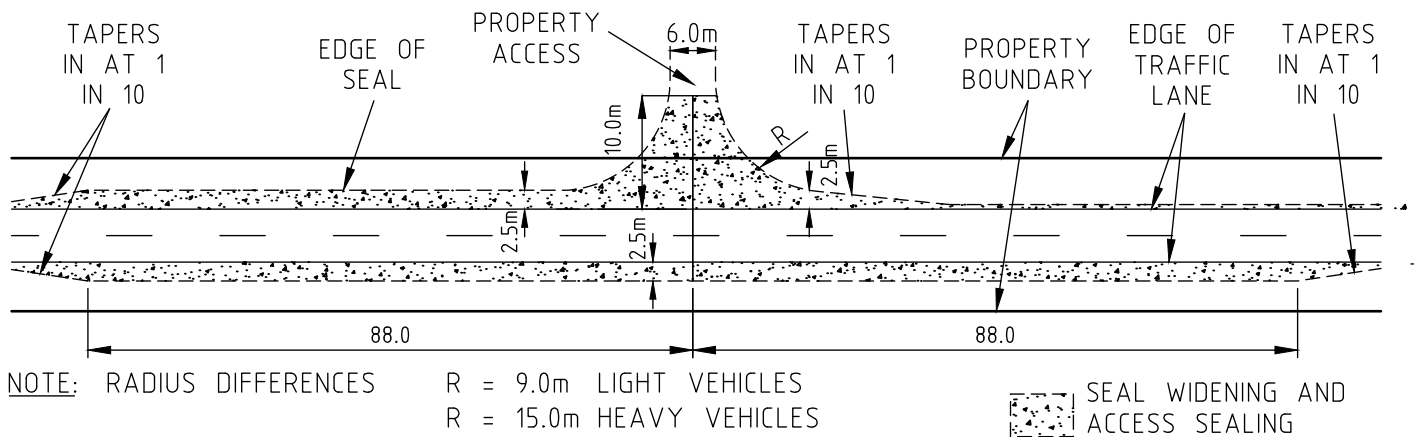

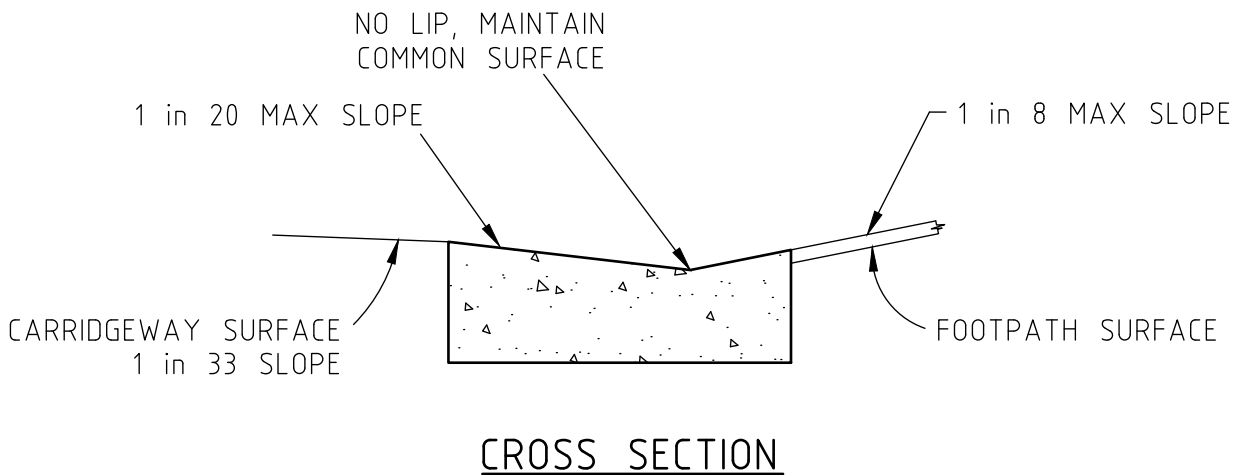
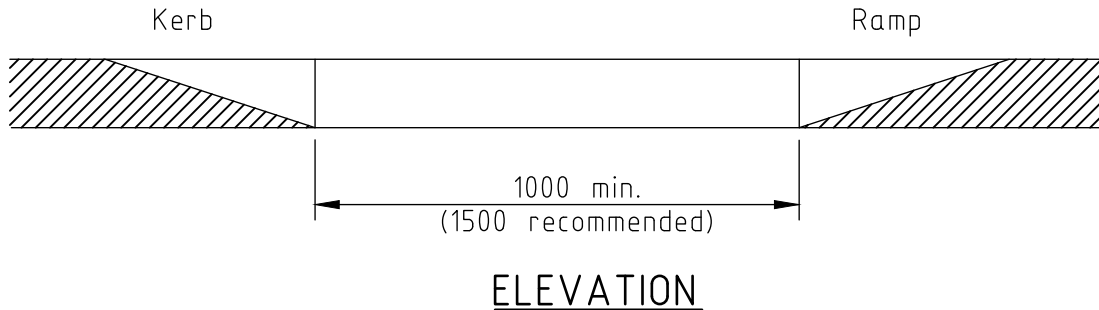
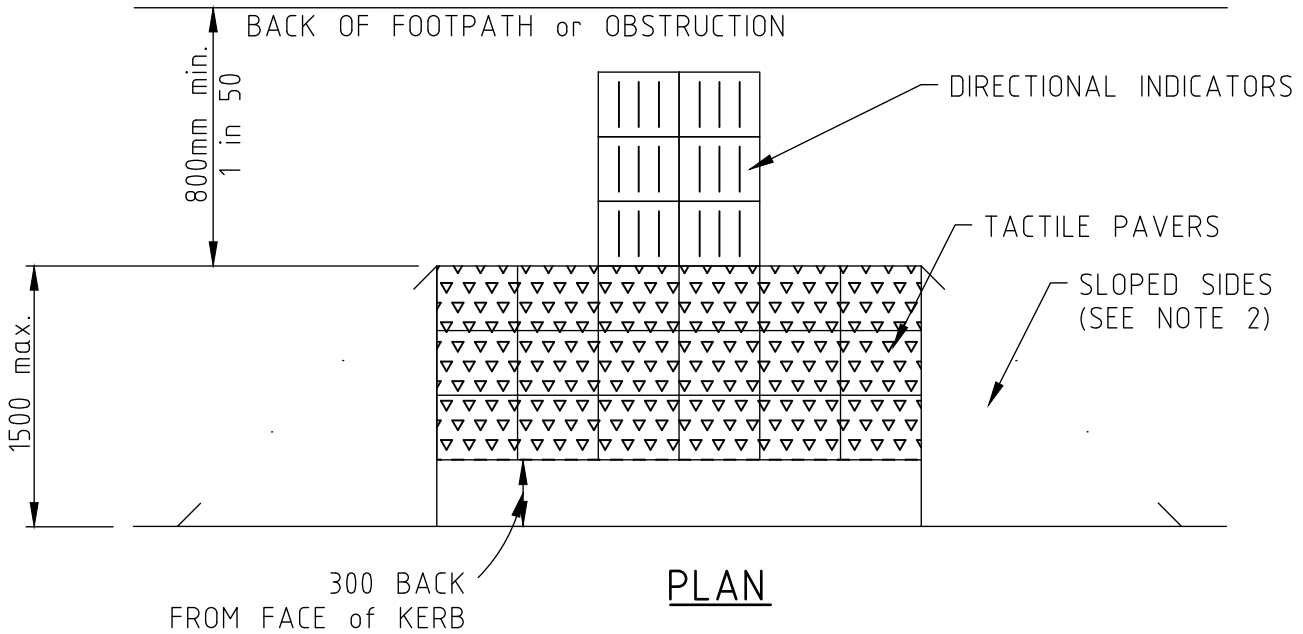

DIAGRAM 3: VEHICLE CROSSING FOR COMMERCIAL OR INDUSTRIAL ACTIVITY

NOTE: VEGETATION CLEARANCE BOTH SIDES OF ENTRANCEWAY TO ENHANCE SITE VISIBILITY.

NELSON CITY COUNCIL  GROUP MANAGER INFRASTRUCTURE, NELSON		RURAL ACCESS DETAILS	
TASMAN DISTRICT COUNCIL  ENGINEERING SERVICES MANAGER, TASMAN		DATE 01/07/19	NELSON - TASMAN LAND DEVELOPMENT MANUAL
			409



NOTES:

1. FOR LAYOUT and INSTALLATION OF TACTILE PAVING & DIRECTIONAL INDICATORS, SEE SECTION 4.13.4
2. SLOPED SIDES SHALL HAVE A MAXIMUM GRADIENT OF 1 in 8 WHERE ABUTTING A FOOTPATH. WHERE THE SLOPED SIDE ABUTS A BERM, THE GRADIENT CAN BE INCREASED TO 1 in 6

<p>NELSON CITY COUNCIL</p> <p><i>[Signature]</i></p> <p>GROUP MANAGER INFRASTRUCTURE, NELSON</p>	<p>PEDESTRIAN KERB CROSSING AND RAMP</p>		
<p>TASMAN DISTRICT COUNCIL</p> <p><i>[Signature]</i></p> <p>ENGINEERING SERVICES MANAGER, TASMAN</p>	<p>DATE</p> <p>01/07/19</p>	<p>NELSON - TASMAN LAND DEVELOPMENT MANUAL</p>	<p>410</p>

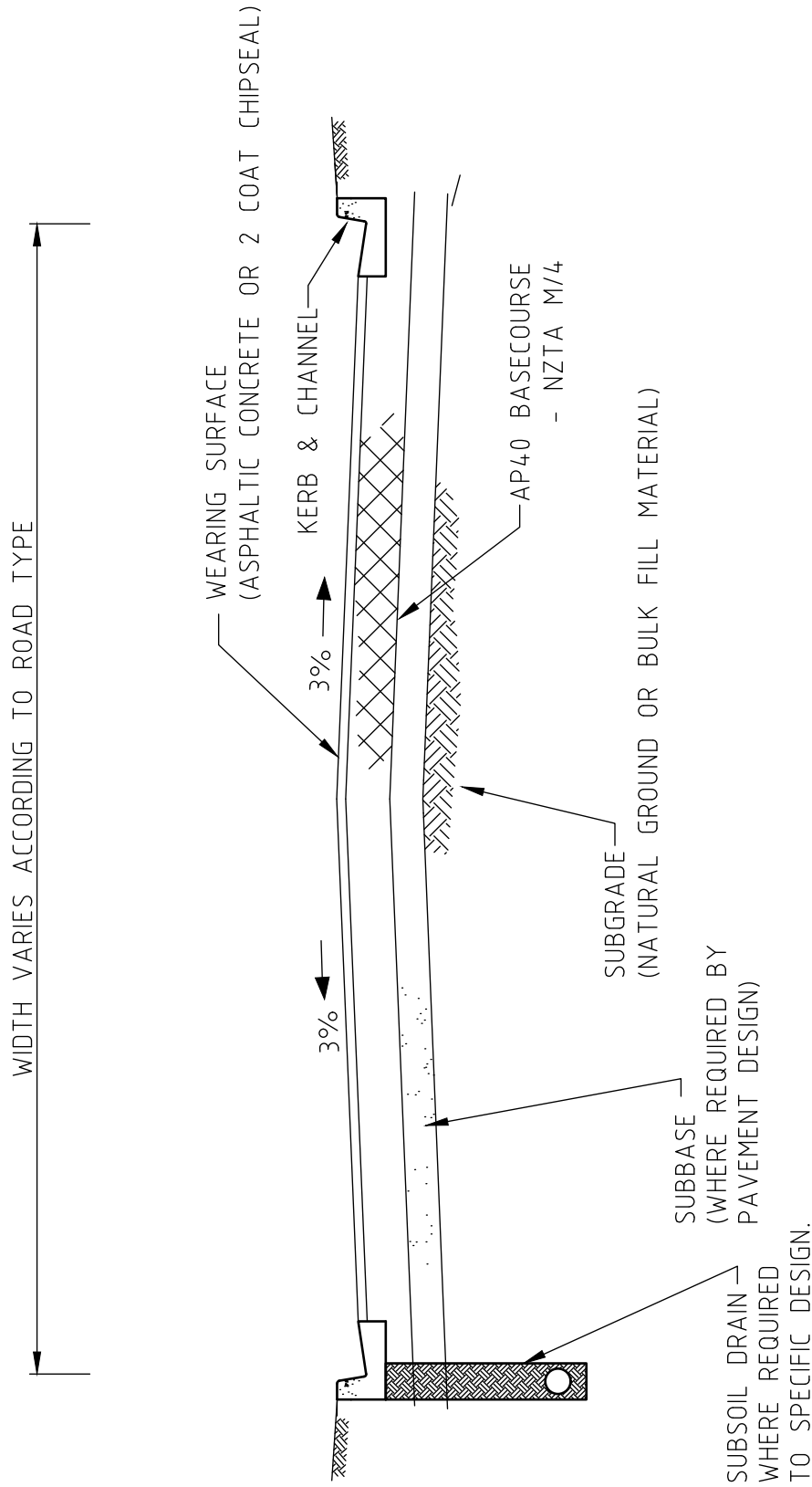

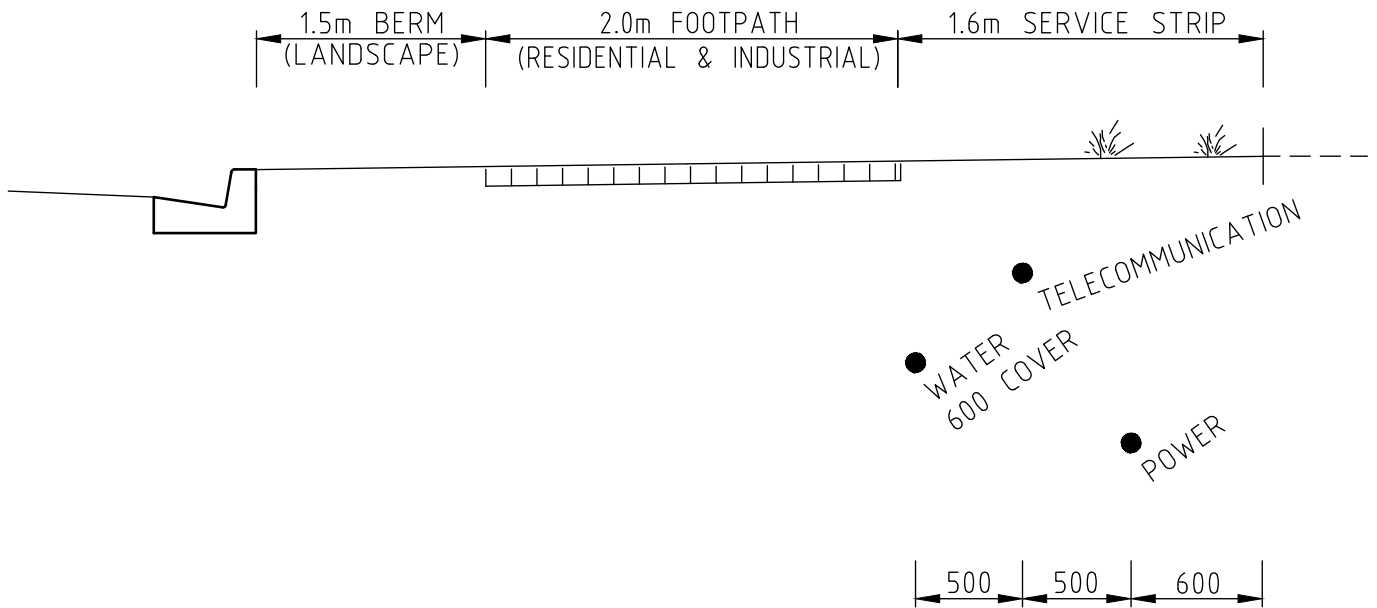
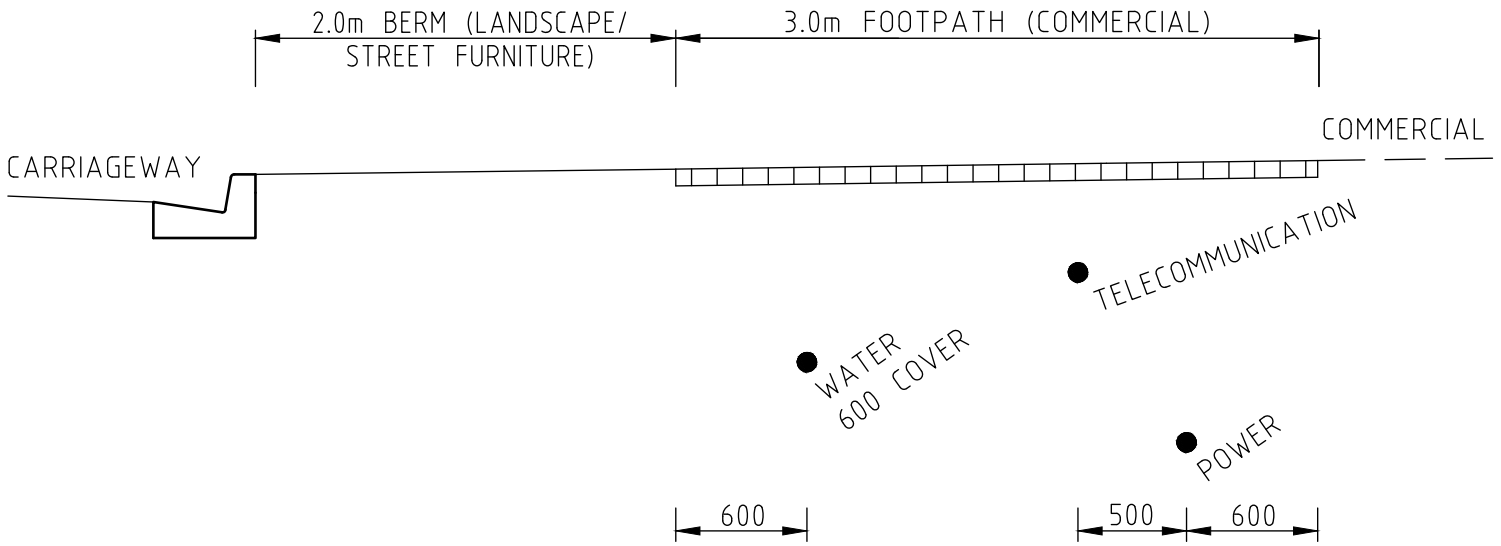

DEPTHS OF BASECOURSE AND SUBBASE
(WHERE REQUIRED) TO BE AS DETAILED IN
SPECIFIC PAVEMENT DESIGN FOR EACH
INDIVIDUAL STREET

<p>NELSON CITY COUNCIL</p> <p><i>[Signature]</i></p> <p>GROUP MANAGER INFRASTRUCTURE, NELSON</p>	<p>TYPICAL CROSS SECTION CARRIAGEWAY - URBAN ROADS</p>		
<p>TASMAN DISTRICT COUNCIL</p> <p><i>[Signature]</i></p> <p>ENGINEERING SERVICES MANAGER, TASMAN</p>	<p>DATE</p> <p>01/07/19</p>	<p>NELSON - TASMAN LAND DEVELOPMENT MANUAL</p>	<p>411</p>



NOTES:

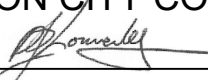

1. SERVICES BERM CAN BE REDUCED TO 0.5m WHERE SERVICES ARE UNDER THE FOOTPATH PROVIDED THEY DO NOT PRECLUDE THE INTRODUCTION OF STREET TREES
2. THE DEPTH OF CABLES MAY VARY. SEE SECTION 9 FOR POWER AND COMMUNICATION CABLE RETICULATION

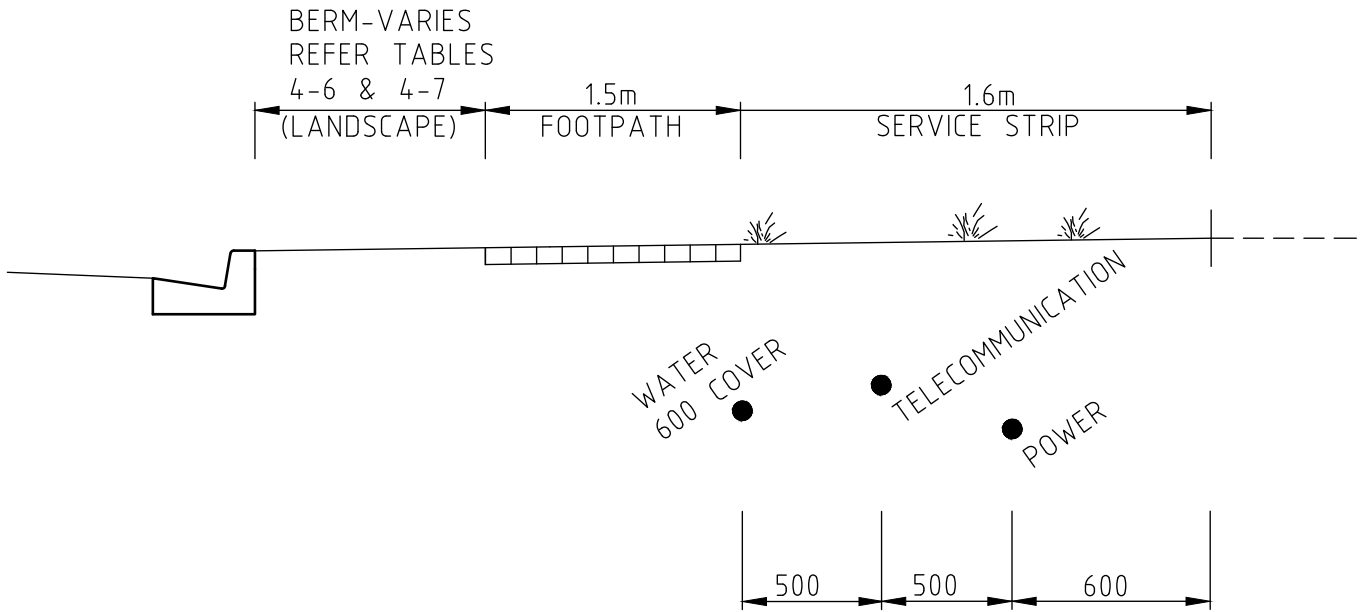
<p>NELSON CITY COUNCIL</p>  <p>GROUP MANAGER INFRASTRUCTURE, NELSON</p>	<p>TYPICAL CROSS SECTIONS (BERMS) ARTERIAL AND PRINCIPAL ROADS</p>		
<p>TASMAN DISTRICT COUNCIL</p>  <p>ENGINEERING SERVICES MANAGER, TASMAN</p>	<p>DATE</p> <p>01/07/19</p>	<p>NELSON - TASMAN LAND DEVELOPMENT MANUAL</p>	<p>412</p>

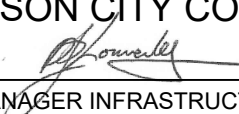

NOTES:

1. SERVICES BERM CAN BE REDUCED TO 0.5m WHERE SERVICES ARE LOCATED UNDER THE FOOTPATH PROVIDED THEY DO NOT PRECLUDE THE INTRODUCTION OF STREET TREES
2. THE DEPTH OF CABLES MAY VARY. SEE SECTION 9 FOR POWER AND COMMUNICATION CABLE RETICULATION

NELSON CITY COUNCIL  GROUP MANAGER INFRASTRUCTURE, NELSON		TYPICAL CROSS SECTIONS (BERMS) COLLECTOR, SUB COLLECTOR & LOCAL ROADS	
TASMAN DISTRICT COUNCIL  ENGINEERING SERVICES MANAGER, TASMAN	DATE 01/07/19	NELSON - TASMAN LAND DEVELOPMENT MANUAL	413

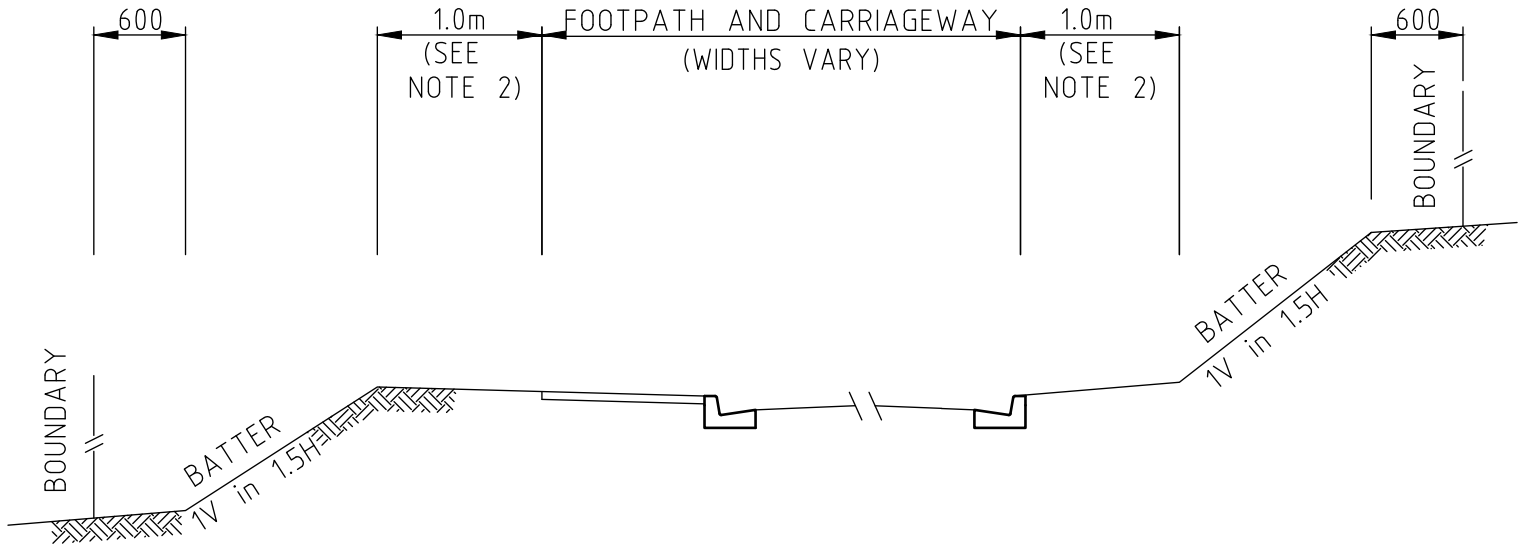

NOTES:

1. RETAINING WALLS WHICH ARE NOT FOR SUPPORTING THE ROAD CARRIGEWAY OR FOOTPATH MUST BE LOCATED OUTSIDE LEGAL ROAD RESERVE
2. THE 1.0m DISTANCE FROM BACK OF FOOTPATH/KERB MAY BE INCREASED WHERE THE AREA IS REQUIRED AS SERVICE STRIPS BY 412 & 413.

<p>NELSON CITY COUNCIL</p> <p><i>[Signature]</i></p> <p>GROUP MANAGER INFRASTRUCTURE, NELSON</p>	<p>TYPICAL CROSS SECTIONS ROADSIDE BATTERS</p>		
<p>TASMAN DISTRICT COUNCIL</p> <p><i>[Signature]</i></p> <p>ENGINEERING SERVICES MANAGER, TASMAN</p>	<p>DATE</p> <p>01/07/19</p>	<p>NELSON - TASMAN LAND DEVELOPMENT MANUAL</p>	<p>414</p>

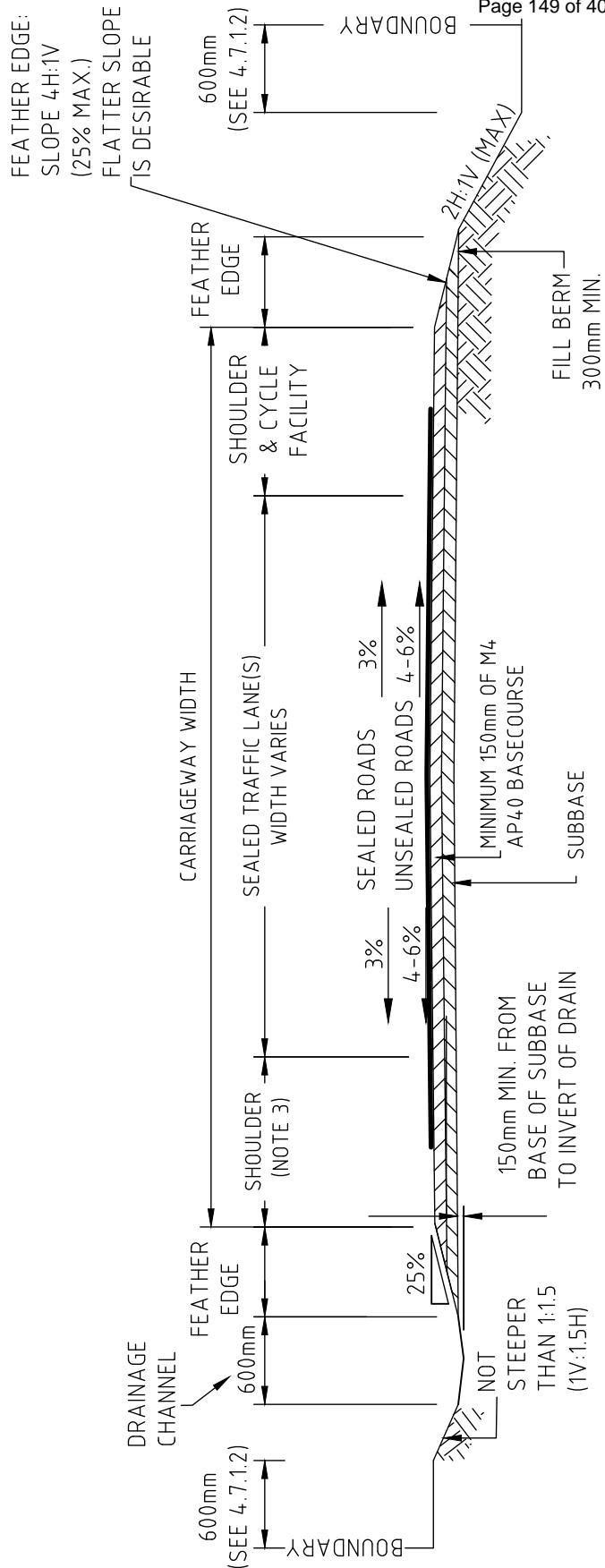

NOTES:

1. DEPTH OF SUBBASE DETERMINED BY INDIVIDUAL PAVEMENT DESIGN FOR EACH STREET/ROAD
2. DRAINAGE CHANNEL SIZE AND SPACING OF STORMWATER CULVERTS, SUBJECT TO SPECIFIC DESIGN
3. FOR SHOULDER & CYCLE FACILITY WIDTHS, SEE CHAPTER 4.6.

NELSON CITY COUNCIL
[Signature]
 GROUP MANAGER INFRASTRUCTURE, NELSON

**TYPICAL CROSS SECTIONS
 RURAL CARRIAGEWAY**

TASMAN DISTRICT COUNCIL
[Signature]
 ENGINEERING SERVICES MANAGER, TASMAN

DATE
 01/07/19

NELSON - TASMAN
 LAND DEVELOPMENT MANUAL

415

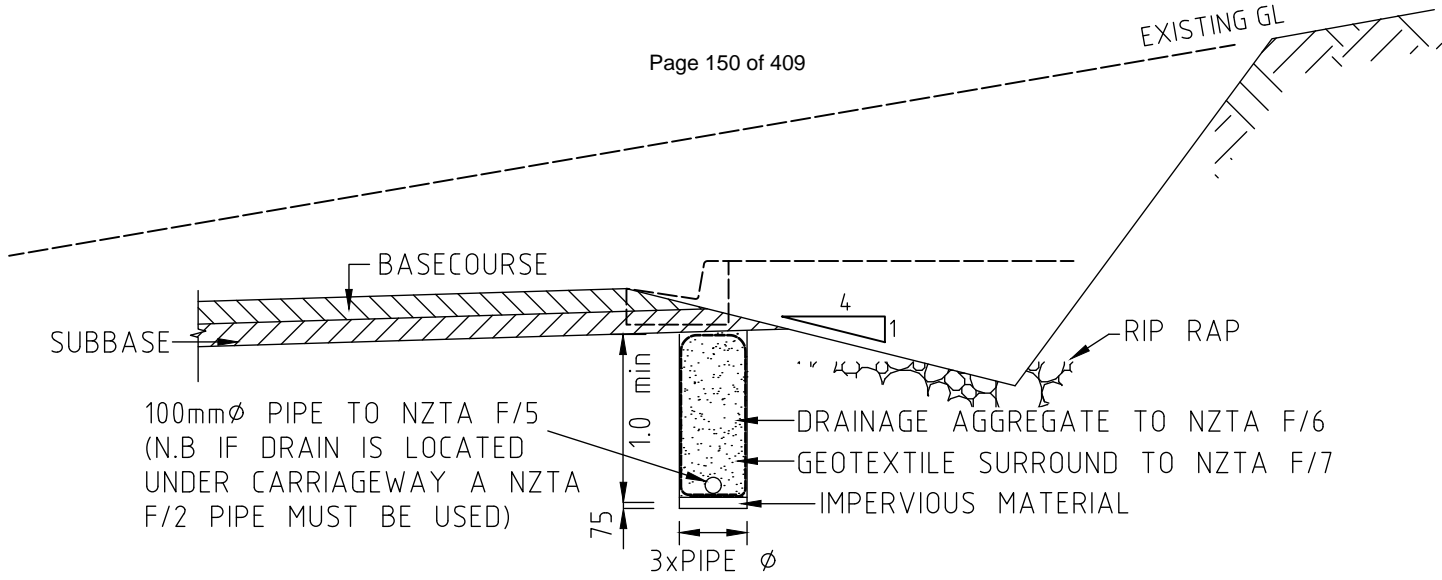

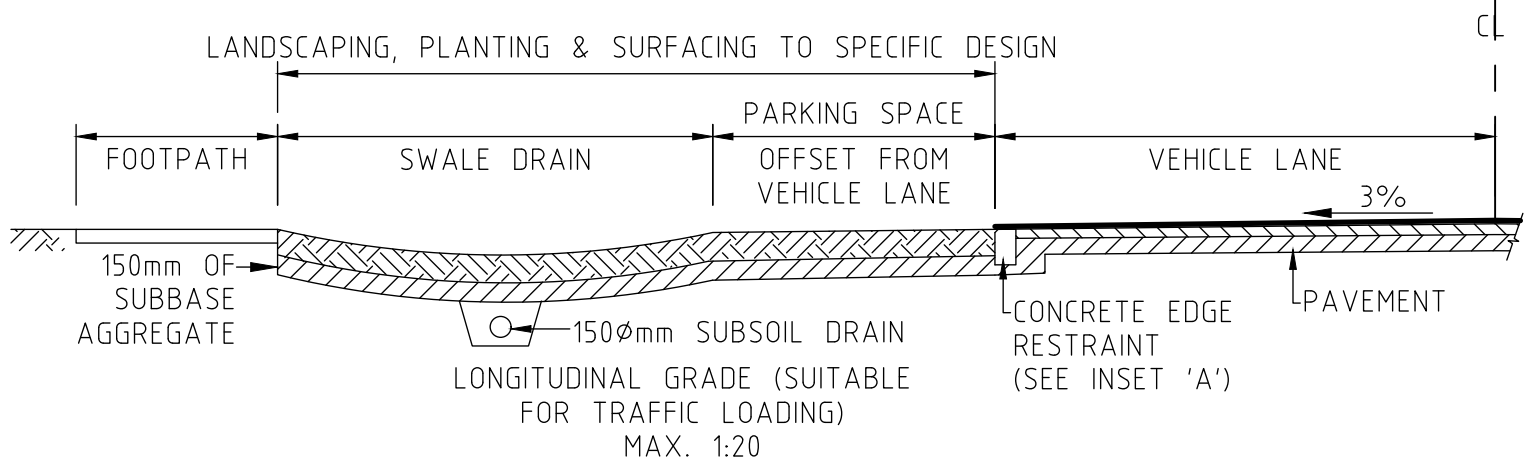

**SUBSOIL DRAIN FILTER DETAIL
(WHEN IN CUT)**

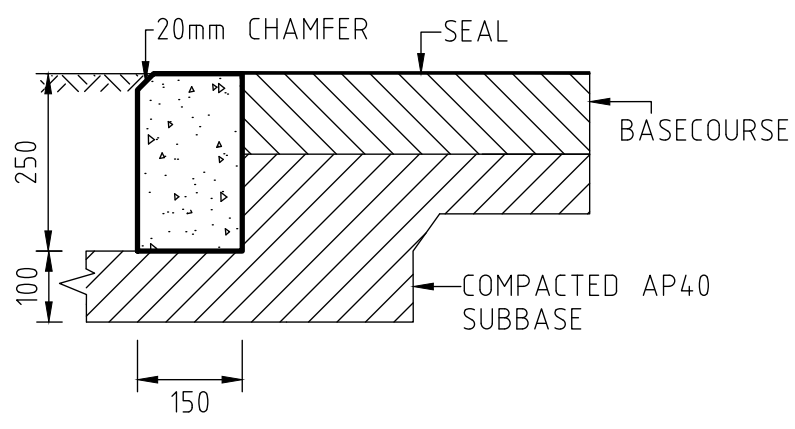

ROADSIDE SWALE DRAINS - SUBJECT TO SPECIFIC DESIGN



INSET 'A'

<p>NELSON CITY COUNCIL  GROUP MANAGER INFRASTRUCTURE, NELSON</p>		<p>TYPICAL DRAINAGE FOR ROADSIDE SWALES & LOW IMPACT STORMWATER</p>	
<p>TASMAN DISTRICT COUNCIL  ENGINEERING SERVICES MANAGER, TASMAN</p>		<p>DATE 01/07/19</p>	<p>NELSON - TASMAN LAND DEVELOPMENT MANUAL</p>
			<p>416</p>

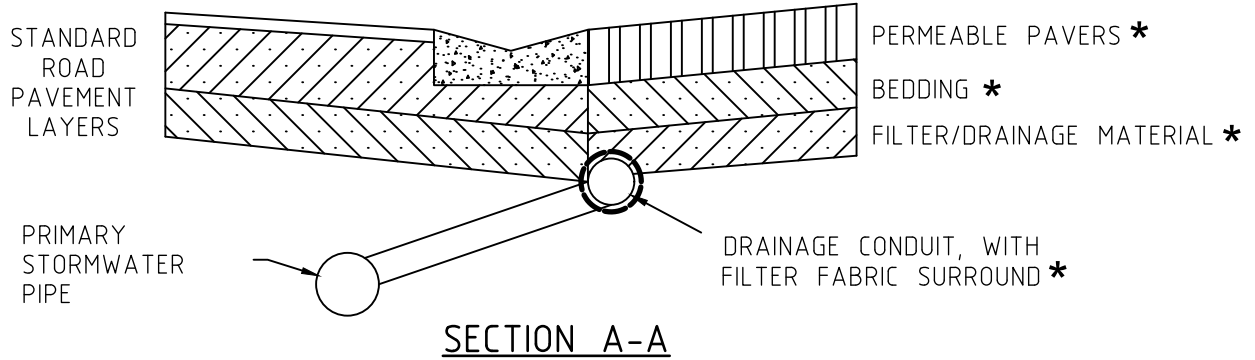

COLLECTION AREA (ON A CASE BY CASE BASIS)
FOR WASTE RECYCLING BINS (COULD BE ON
OTHER SIDE OF ROAD). REFER SECTION 4.6.4.4

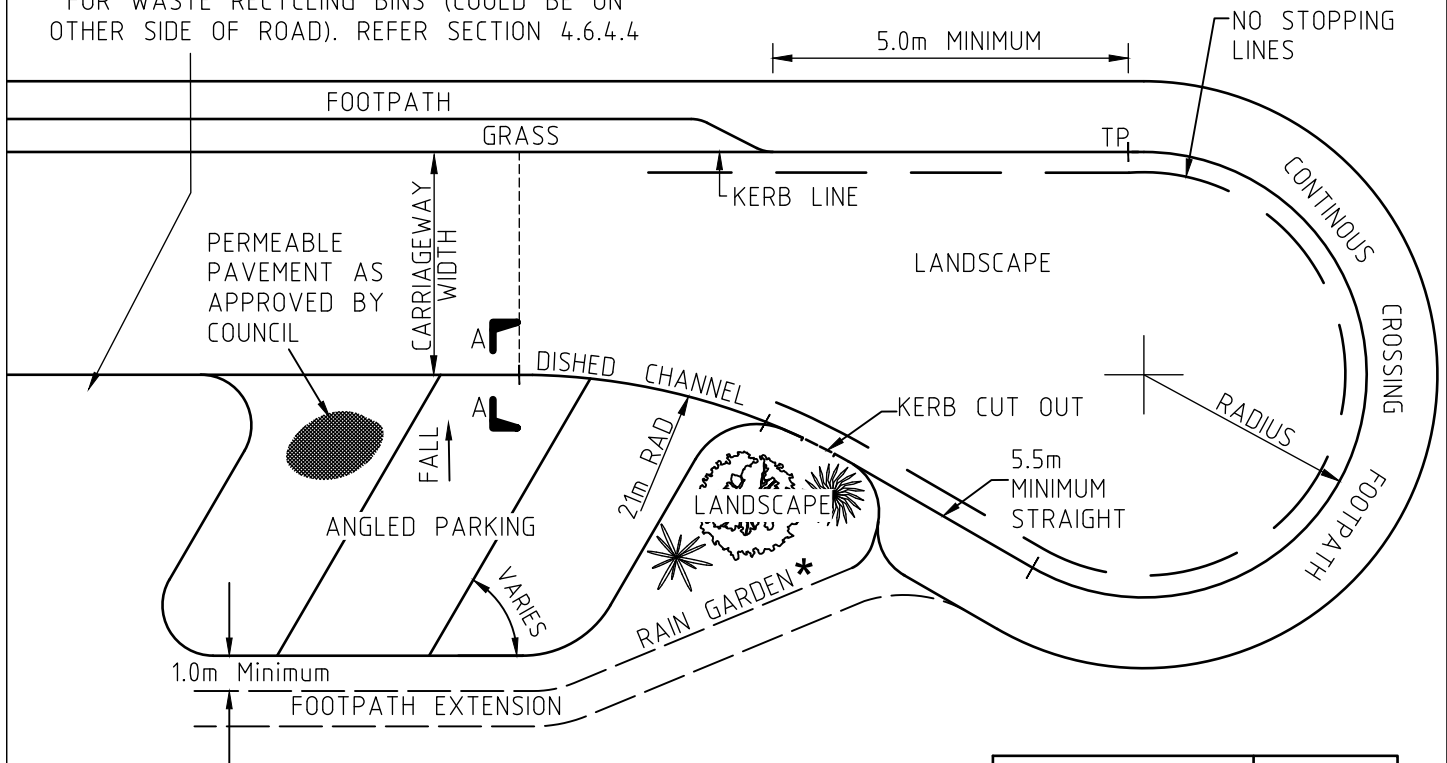



ZONE	RADIUS
RESIDENTIAL	7.0
COMMERCIAL	11.0
INDUSTRIAL	12.0
RURAL LIFESTYLE	8.0

NOTES:

1. NO KERBSIDE PARKING WITHIN THE TURNING CIRCLE
2. FOR RESIDENTIAL DEVELOPMENT ON STEEP HILLSIDE, THE CUL-DE-SAC MAY BE A 'FISH-TAIL' OR 'HAMMERHEAD' DESIGN PROVIDED THE TURNING AREA PERMITS A 90 PERCENTILE 2 AXLE TRUCK TO UNDERTAKE A 3 POINT TURN
3. THIS DRAWING IS AN EXAMPLE CONCEPT ONLY AND THERE ARE OTHER COMPLYING DESIGNS FOR CUL-DE-SAC TURNING HEADS

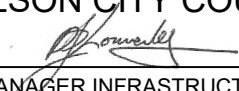
* (SPECIFIC DESIGN REQUIRED)

<p>NELSON CITY COUNCIL</p>  <p>GROUP MANAGER INFRASTRUCTURE, NELSON</p>		<p>CUL-DE-SAC TURNING CIRCLES</p>	
<p>TASMAN DISTRICT COUNCIL</p>  <p>ENGINEERING SERVICES MANAGER, TASMAN</p>		<p>DATE</p> <p>01/07/19</p>	<p>NELSON - TASMAN LAND DEVELOPMENT MANUAL</p>
			<p>417</p>

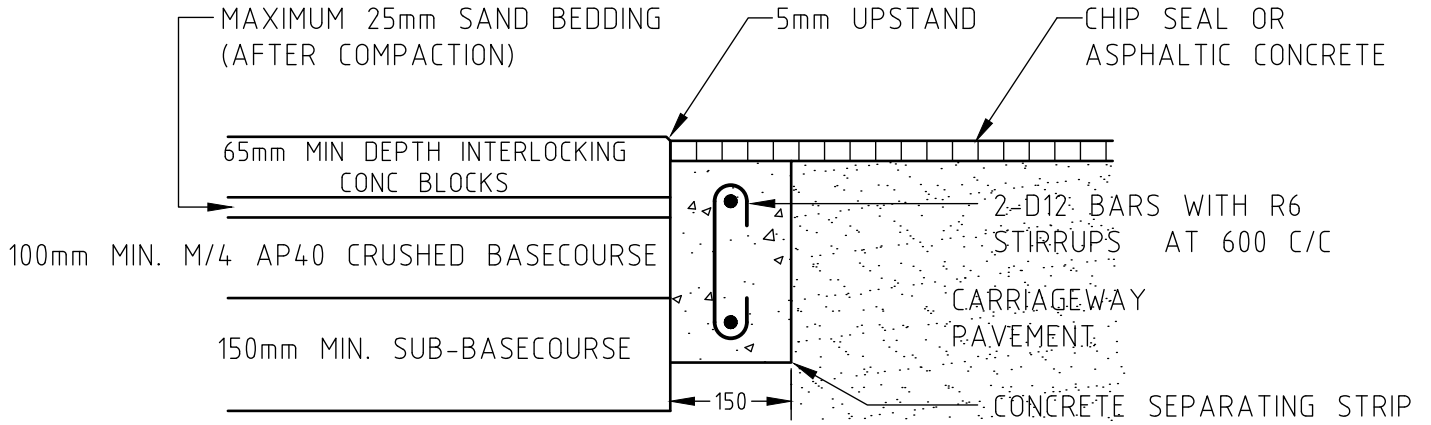

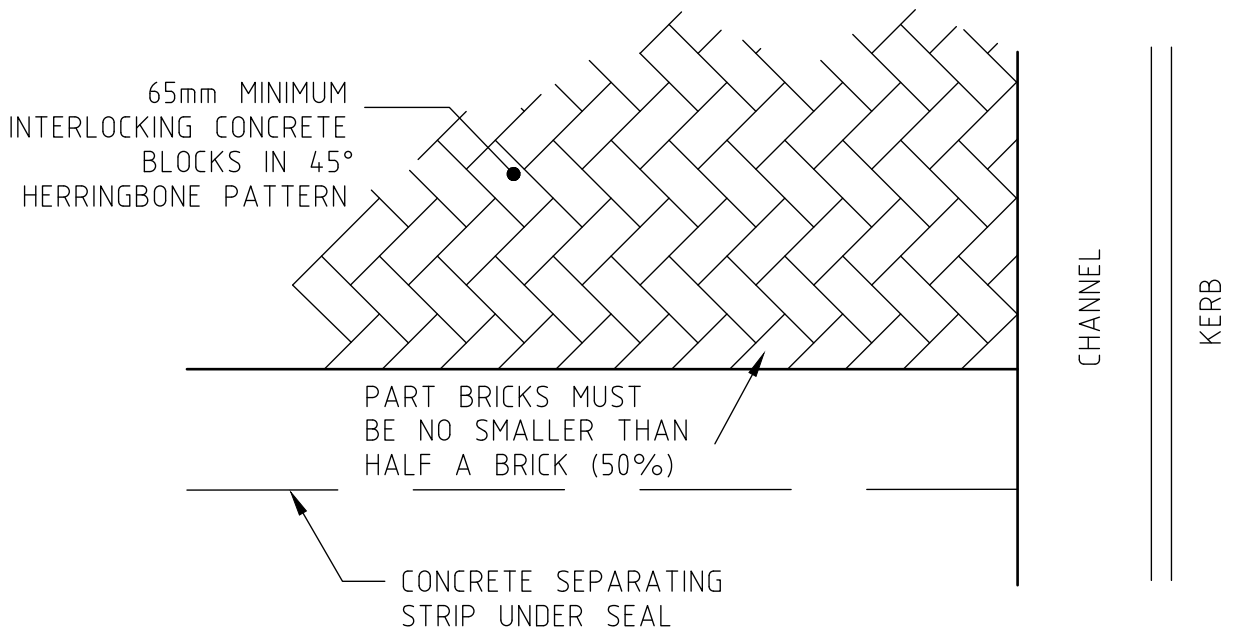

**CARRIAGEWAY THRESHOLDS
(LONGITUDINAL SECTION)**



**CARRIAGEWAY THRESHOLDS
PART PLAN**

NOTES:

1. CONCRETE BLOCKS SHALL COMPLY WITH NZS 3116: 2002
2. LAYING OF BLOCKS SHALL COMPLY WITH THE CEMENT AND CONCRETE ASSOCIATION OF NZ "INTERLOCKING CONCRETE BLOCK ROAD PAVEMENTS" (SEPT 1988)
3. COLOUR OF BRICKS TO BE GREY AND APPROVED BY COUNCIL
4. IN HIGH TRAFFIC AREAS (COLLECTOR ROAD CATEGORY OR HIGHER) THE BLOCKS SHALL BE LAID ON 150mm DEPTH OF REINFORCED CONCRETE (SUBJECT TO SPECIFIC DESIGN)

<p>NELSON CITY COUNCIL</p>  <p>GROUP MANAGER INFRASTRUCTURE, NELSON</p>		<p>CARRIAGEWAY THRESHOLDS (CONCRETE BLOCKS)</p>	
<p>TASMAN DISTRICT COUNCIL</p>  <p>ENGINEERING SERVICES MANAGER, TASMAN</p>	<p>DATE</p> <p>01/07/19</p>	<p>NELSON - TASMAN LAND DEVELOPMENT MANUAL</p>	<p>418</p>

NOTES:

1. USE 50mm Sq. WASHER TO TIMBER BOLTS:
Min. TIMBER EDGE DIST.=65mm
Min. EDGE DIST. to STEEL PLATE=18mm
PLATE:
140 x 80 x 6 PLATE
FILLET WELD TO PIPE
ARCSPRAY ALL STEEL
PLACE MALTHOID BETWEEN STEEL AND TIMBER
2. MAXIMUM OPENING SPACE OF THE CHAIN LINK SHALL BE 35mm OR 50mm DIAMETER
3. DESIGN TO DBH (MARCH 12) SEE NOTE "GUIDANCE ON BARRIER DESIGN"

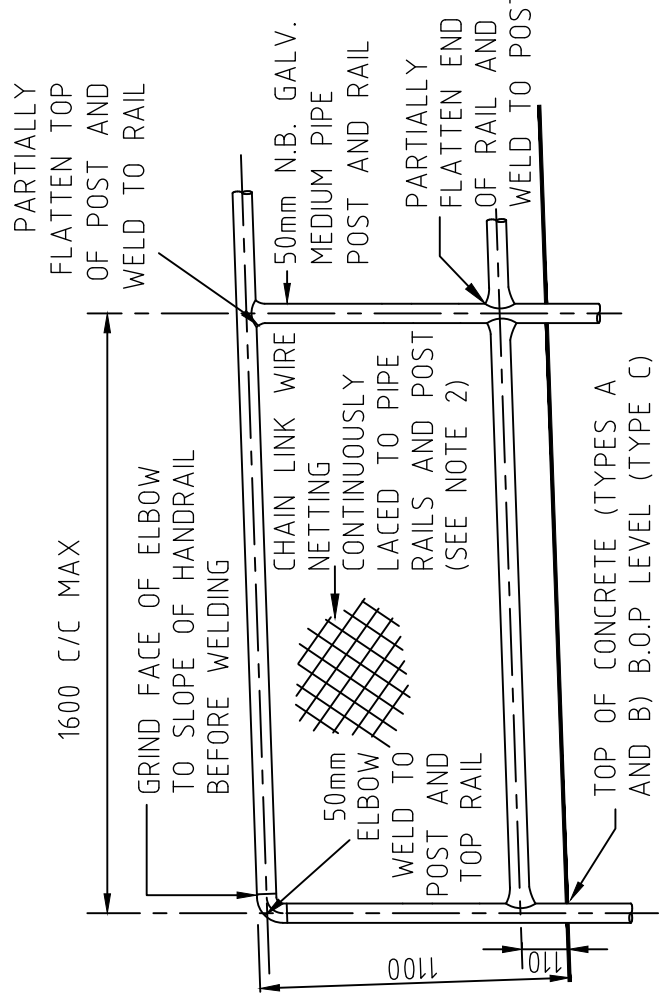
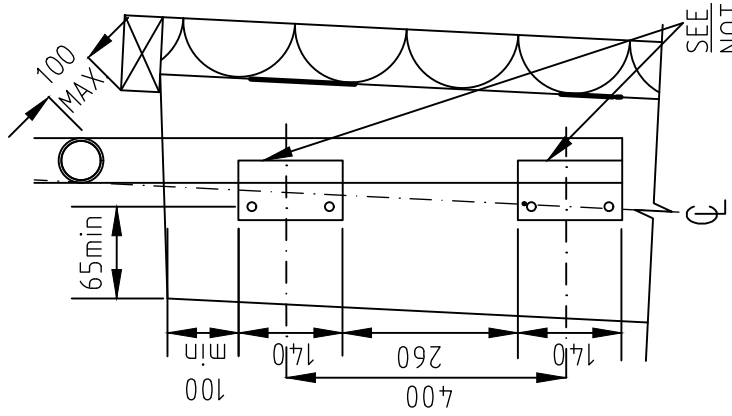

TYPICAL ELEVATION

FIXING TO TIMBER POLE

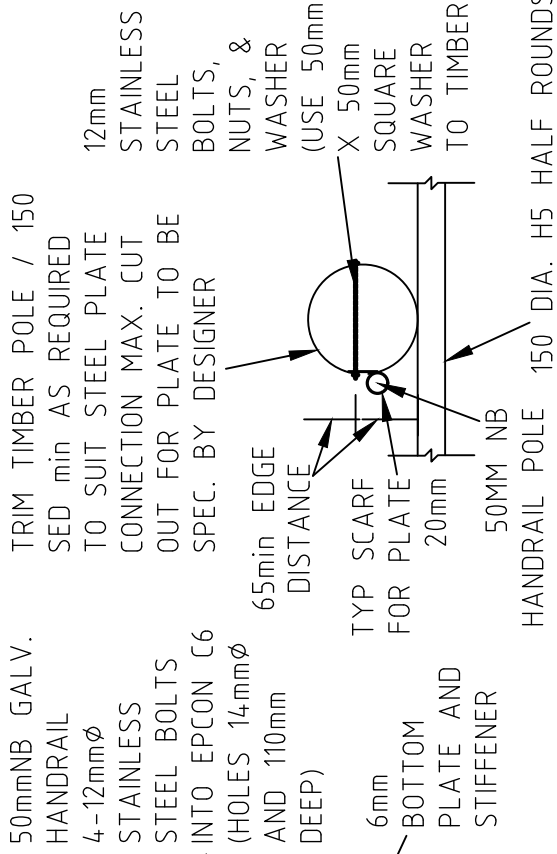
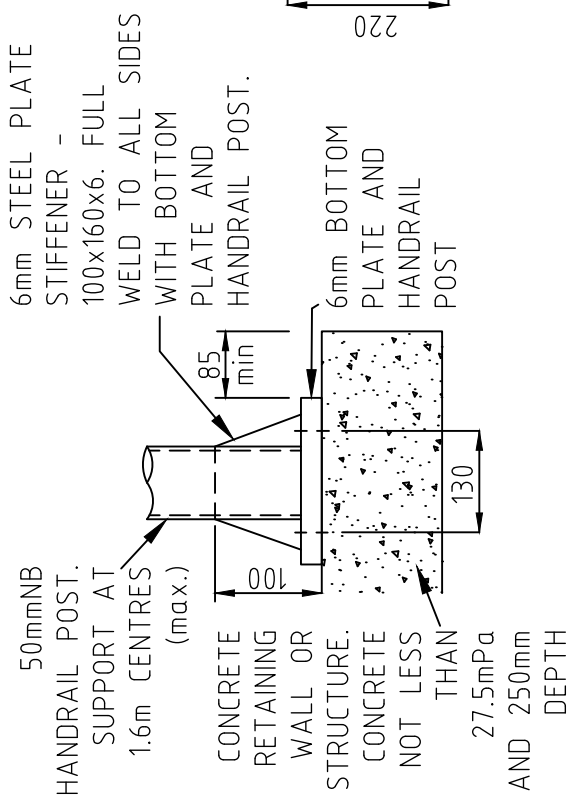

DETAIL (NTS) - FIXING TO CONCRETE SURFACE

TYPICAL CONNECTION PLAN

NELSON CITY COUNCIL

[Signature]
GROUP MANAGER INFRASTRUCTURE, NELSON

ALTERNATIVE HANDRAIL CHAIN LINK

TASMAN DISTRICT COUNCIL

[Signature]
ENGINEERING SERVICES MANAGER, TASMAN

DATE
01/07/19

NELSON - TASMAN
LAND DEVELOPMENT MANUAL

419

NOTES:
ALUMINIUM REFER
TO ALUMINIUM
ALLOY 6063

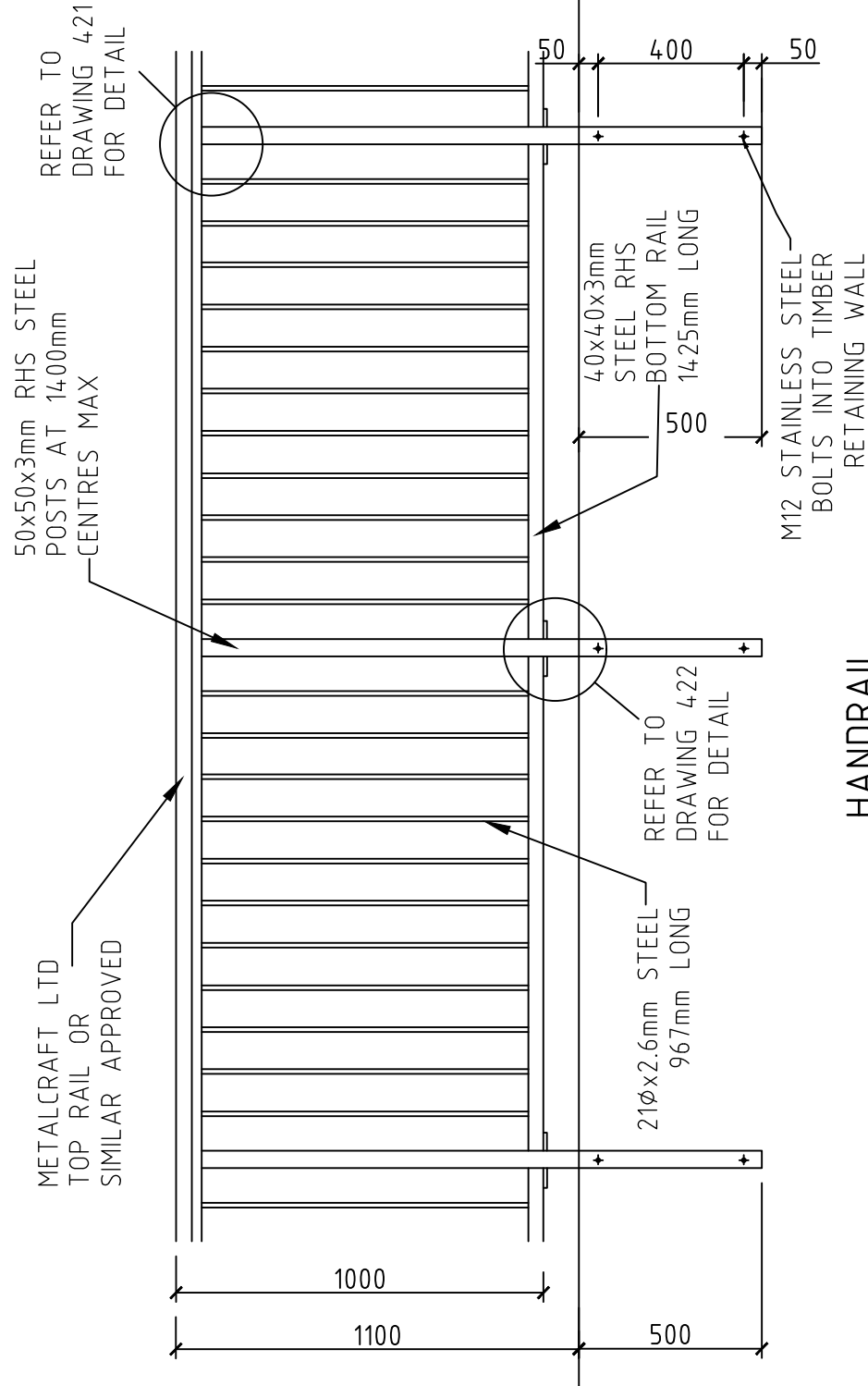

HANDRAIL

- FINISH COATINGS:**
- ALUMINIUM - TO BE POWDER COATED IN ORDER TO PROVIDE 15 YEARS WARRANTY
 - STEEL PARTS/SURFACES - TO BE GALVANIZED (HOT DIP) OR ZINC METAL SPRAYED (ARC SPRAY) TO 150 MICROS ZINC COATING THICKNESS AND WITH A COVER COAT OF TWO POT EPOXY OR POWDER COATING. GALVANIZED COATING MUST BE LIGHTLY SANDED BEFORE COVER COATING

NELSON CITY COUNCIL
[Signature]
GROUP MANAGER INFRASTRUCTURE, NELSON

HANDRAIL (1 OF 5)

TASMAN DISTRICT COUNCIL
[Signature]
ENGINEERING SERVICES MANAGER, TASMAN

DATE
01/07/19

NELSON - TASMAN
LAND DEVELOPMENT MANUAL

420

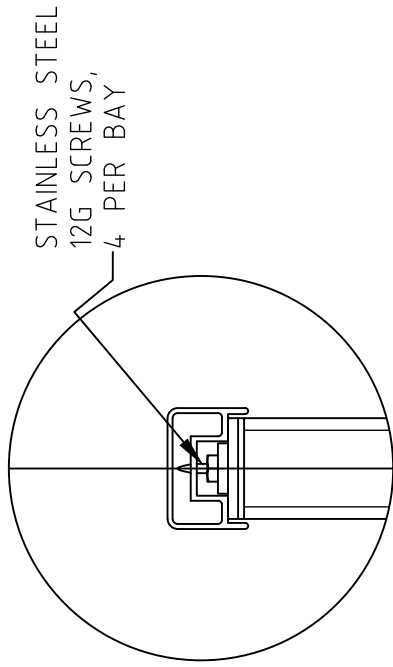

CROSS SECTION D

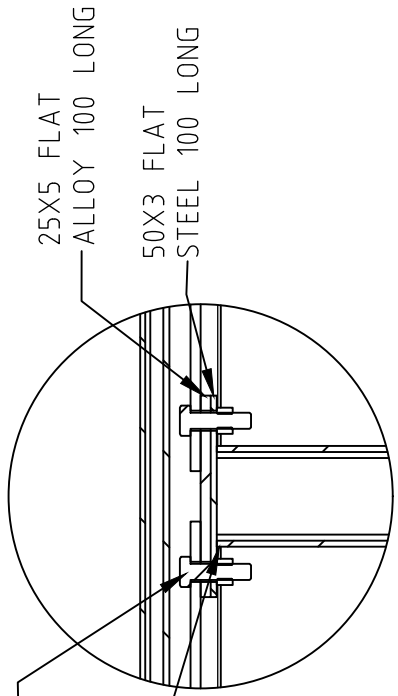

DETAIL C

2/M8X20 STAINLESS STEEL
THREAD BOLTS THROUGH
CHANNEL INTO AND CAP

FILLET WELD
TO RHS POST

25X5 FLAT
ALLOY 100 LONG

50X3 FLAT
STEEL 100 LONG

METALCRAFT LTD TOP RAIL
OR SIMILAR APPROVED

REFER TO
DETAIL C

FILLET WELD
TO RHS POST

STAINLESS STEEL
12G SCREWS,
4 PER BAY

25X5 FLAT STEEL
BEVEL BUTT WELD TO TUBE

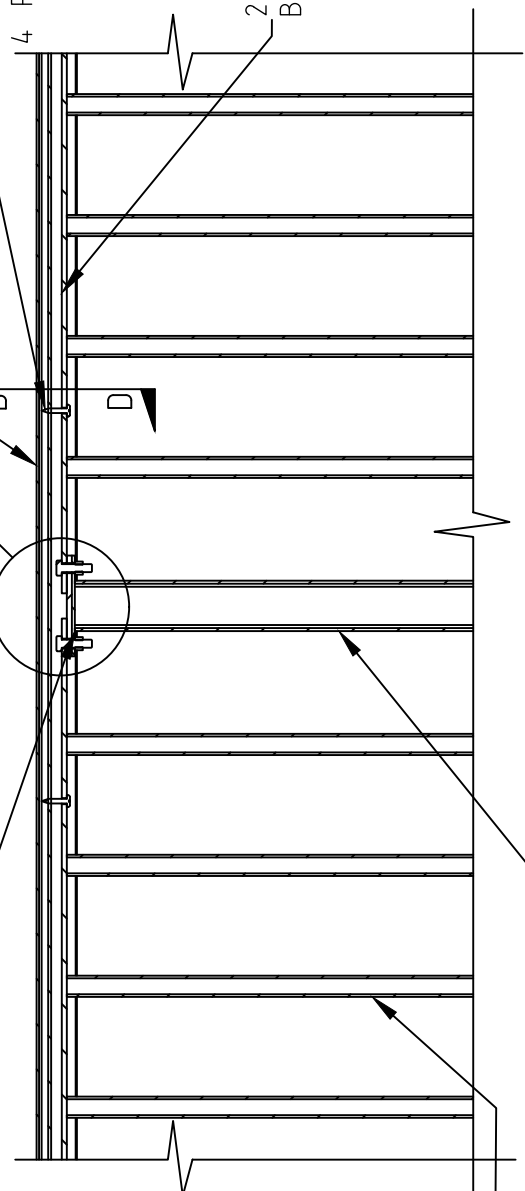

21φx2.6mm STEEL
TUBE AT 115mm
CENTRES MAX

50x50x3mm RHS
STEEL POSTS AT
1400mm CENTRES MAX

DETAIL A - TOP

NELSON CITY COUNCIL

[Signature]
GROUP MANAGER INFRASTRUCTURE, NELSON

HANDRAIL DETAIL (2 OF 5)

TASMAN DISTRICT COUNCIL

[Signature]
ENGINEERING SERVICES MANAGER, TASMAN

DATE
01/07/19

NELSON - TASMAN
LAND DEVELOPMENT MANUAL

421

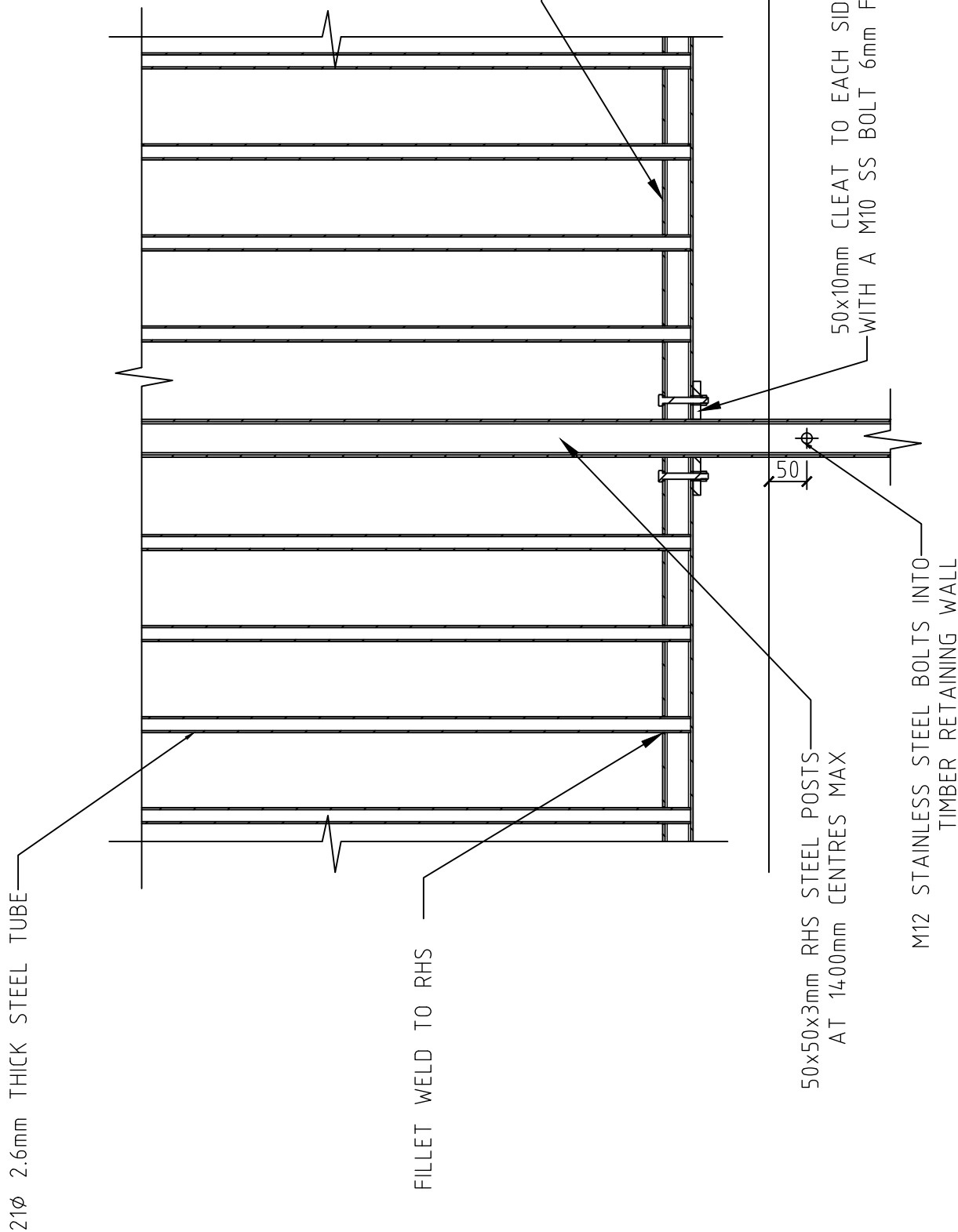

DETAIL B - BOTTOM

<p>NELSON CITY COUNCIL</p> <p><i>[Signature]</i></p> <p>GROUP MANAGER INFRASTRUCTURE, NELSON</p>	<p>HANDRAIL DETAIL (3 OF 5)</p>		
<p>TASMAN DISTRICT COUNCIL</p> <p><i>[Signature]</i></p> <p>ENGINEERING SERVICES MANAGER, TASMAN</p>	<p>DATE</p> <p>01/07/19</p>	<p>NELSON - TASMAN</p> <p>LAND DEVELOPMENT MANUAL</p>	<p>422</p>

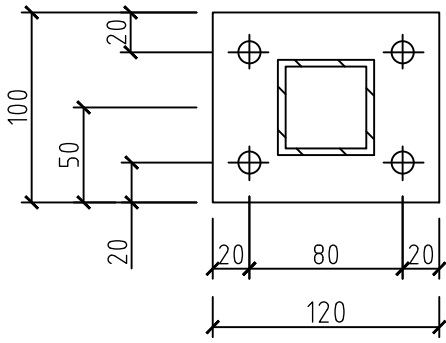

BASE PLATE PLAN

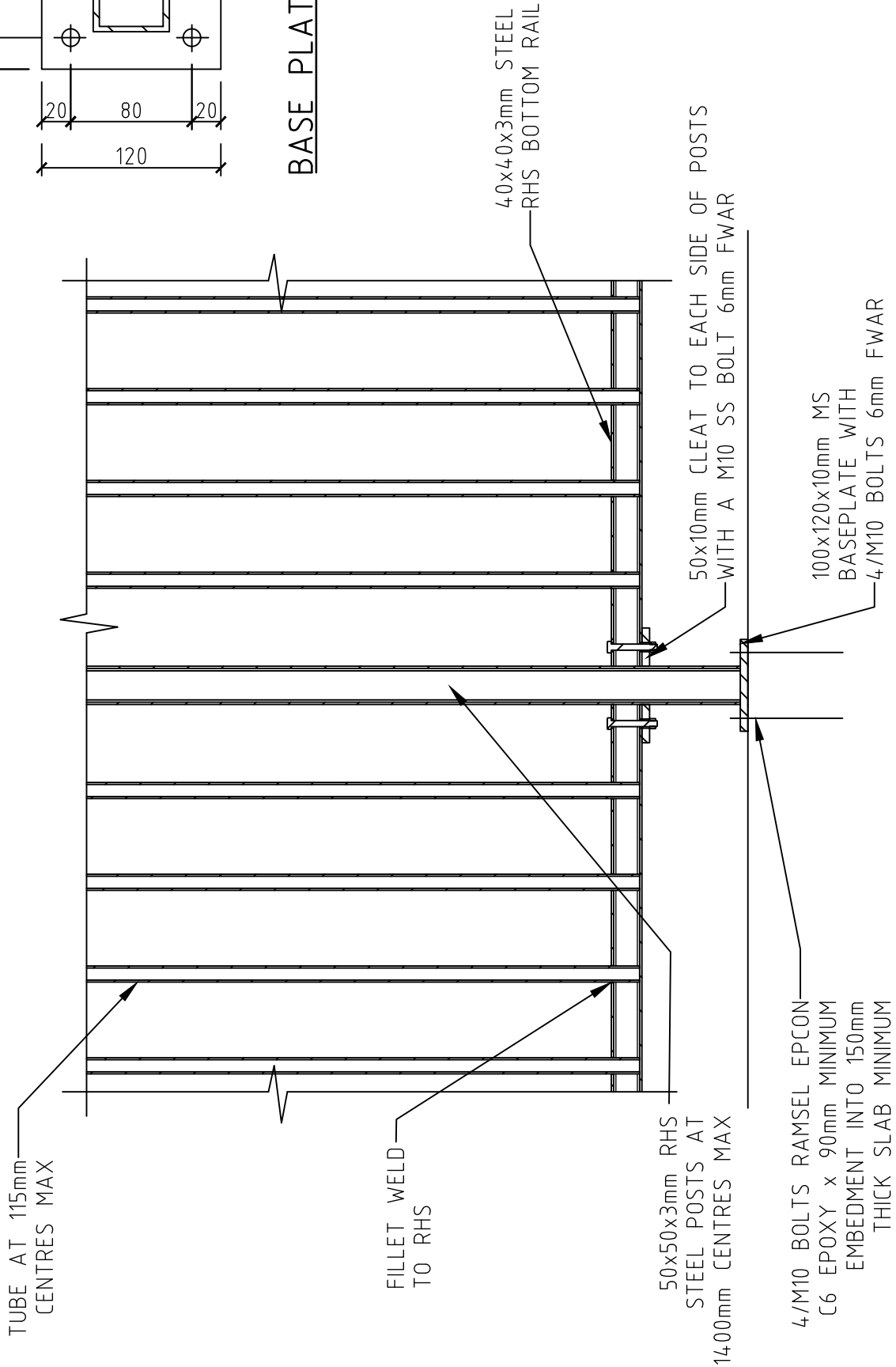

DETAIL B - ALTERNATIVE BOTTOM

NELSON CITY COUNCIL

[Signature]
GROUP MANAGER INFRASTRUCTURE, NELSON

HANDRAIL DETAIL (4 OF 5)

TASMAN DISTRICT COUNCIL

[Signature]
ENGINEERING SERVICES MANAGER, TASMAN

DATE
01/07/19

NELSON - TASMAN
LAND DEVELOPMENT MANUAL

423

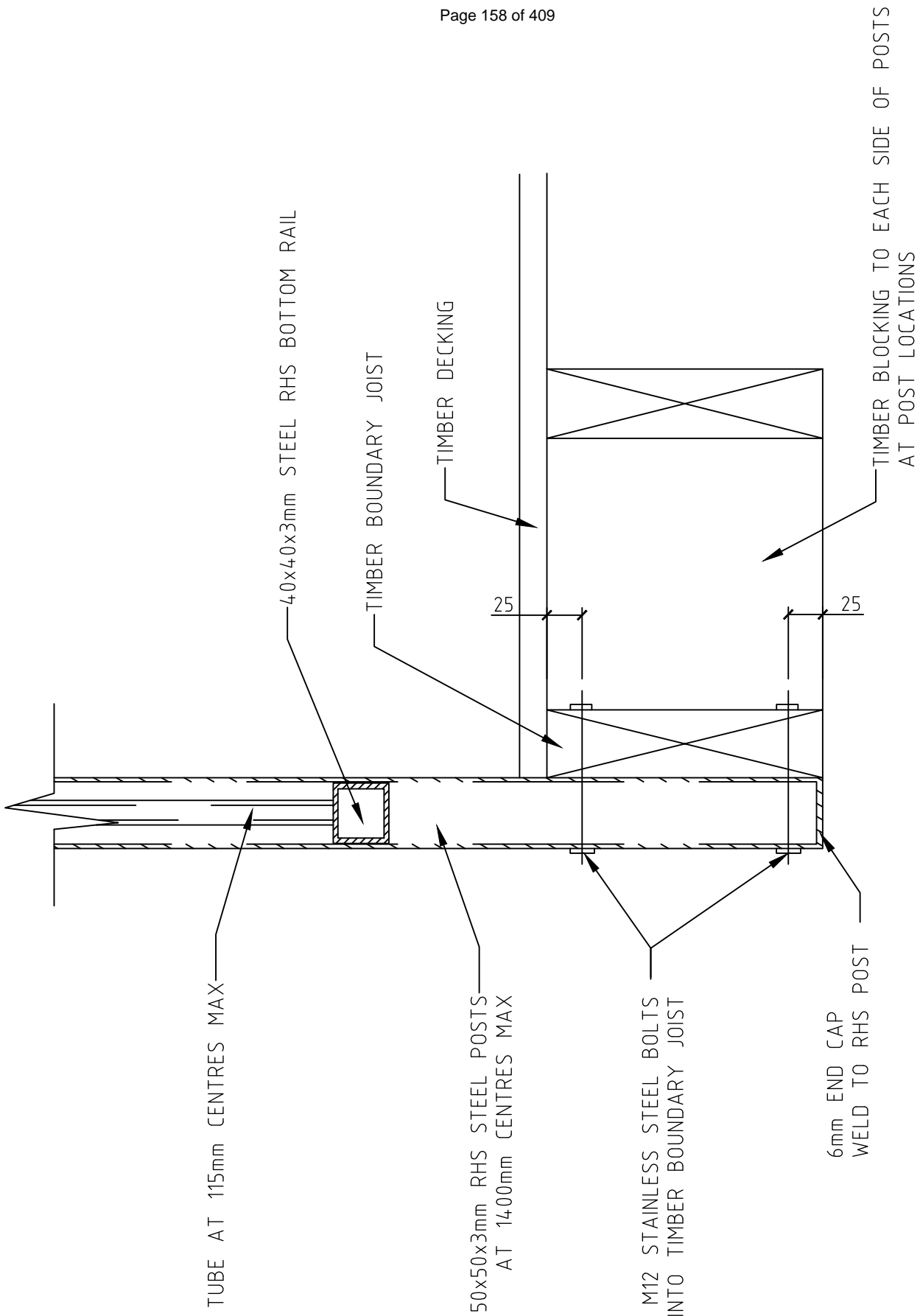

DETAIL B - TIMBER DECK FIXING

NELSON CITY COUNCIL

[Signature]
GROUP MANAGER INFRASTRUCTURE, NELSON

HANDRAIL DETAIL (5 OF 5)

TASMAN DISTRICT COUNCIL

[Signature]
ENGINEERING SERVICES MANAGER, TASMAN

DATE

01/07/19

NELSON - TASMAN
LAND DEVELOPMENT MANUAL

424

PLASTER CAP PERMANENTLY AFFIXED WITH DOWEL STARTER AND PAINTED WHITE.

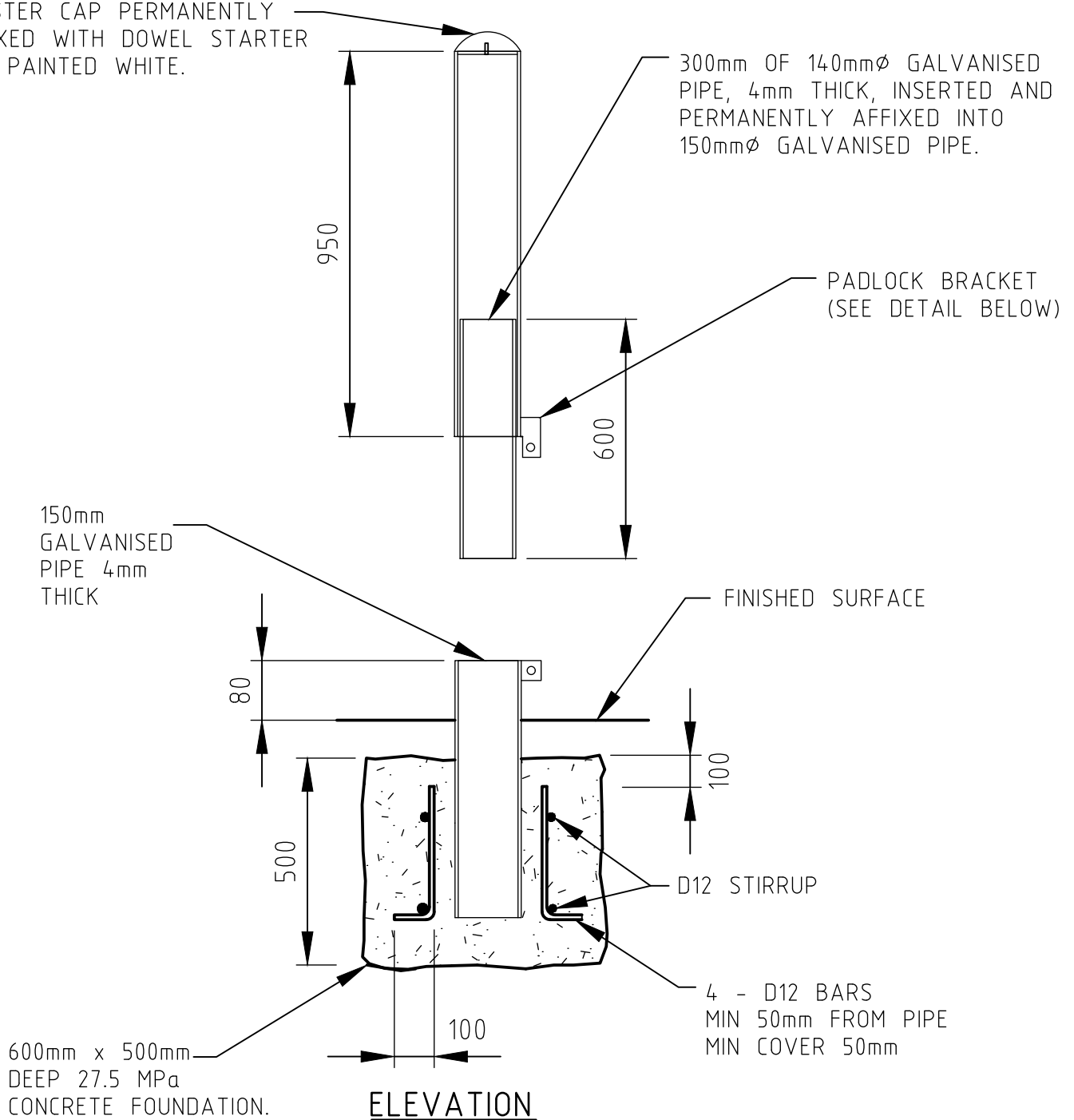

NOTES:

1. ALL STEELWORK SHALL BE PRIMED AND PAINTED WHITE WITH REFLECTIVE STRIPS VISIBLE FROM BOTH WAYS
2. PADLOCK TO BE POSITIONED FACING DIRECTION OF CYCLE TRAFFIC

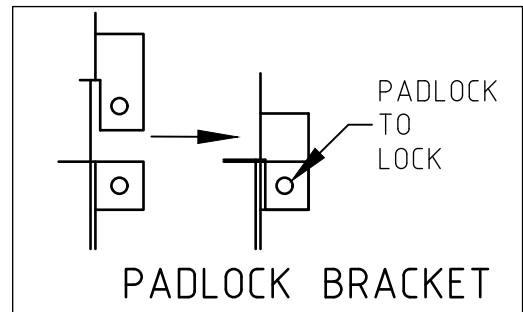

NELSON CITY COUNCIL

[Signature]
GROUP MANAGER INFRASTRUCTURE, NELSON

REMOVABLE CYCLE BOLLARD

TASMAN DISTRICT COUNCIL

[Signature]
ENGINEERING SERVICES MANAGER, TASMAN

DATE

01/07/19

NELSON - TASMAN
LAND DEVELOPMENT MANUAL

425

PLASTER CAP PERMANENTLY
AFFIXED WITH DOWEL STARTER
AND PAINTED WHITE.

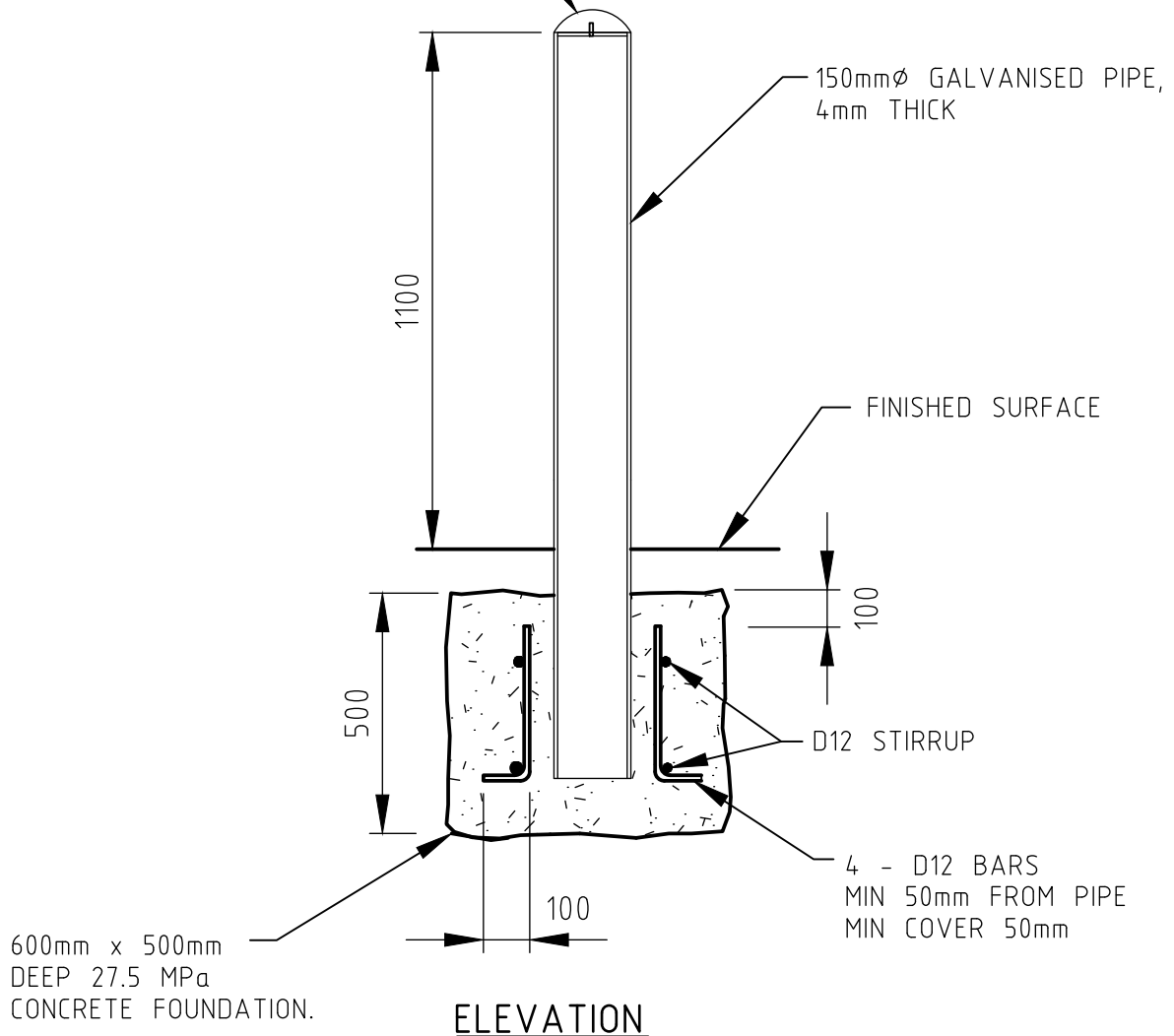

NOTES:

1. ALL STEELWORK SHALL BE PRIMED AND PAINTED WHITE WITH REFLECTIVE STRIPS VISABLE FROM BOTH WAYS

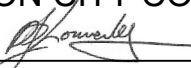
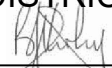
<p>NELSON CITY COUNCIL</p>  <p>GROUP MANAGER INFRASTRUCTURE, NELSON</p>	<p>STANDARD CYCLE BOLLARD</p>		
<p>TASMAN DISTRICT COUNCIL</p>  <p>ENGINEERING SERVICES MANAGER, TASMAN</p>	<p>DATE 01/07/19</p>	<p>NELSON - TASMAN LAND DEVELOPMENT MANUAL</p>	<p>426</p>

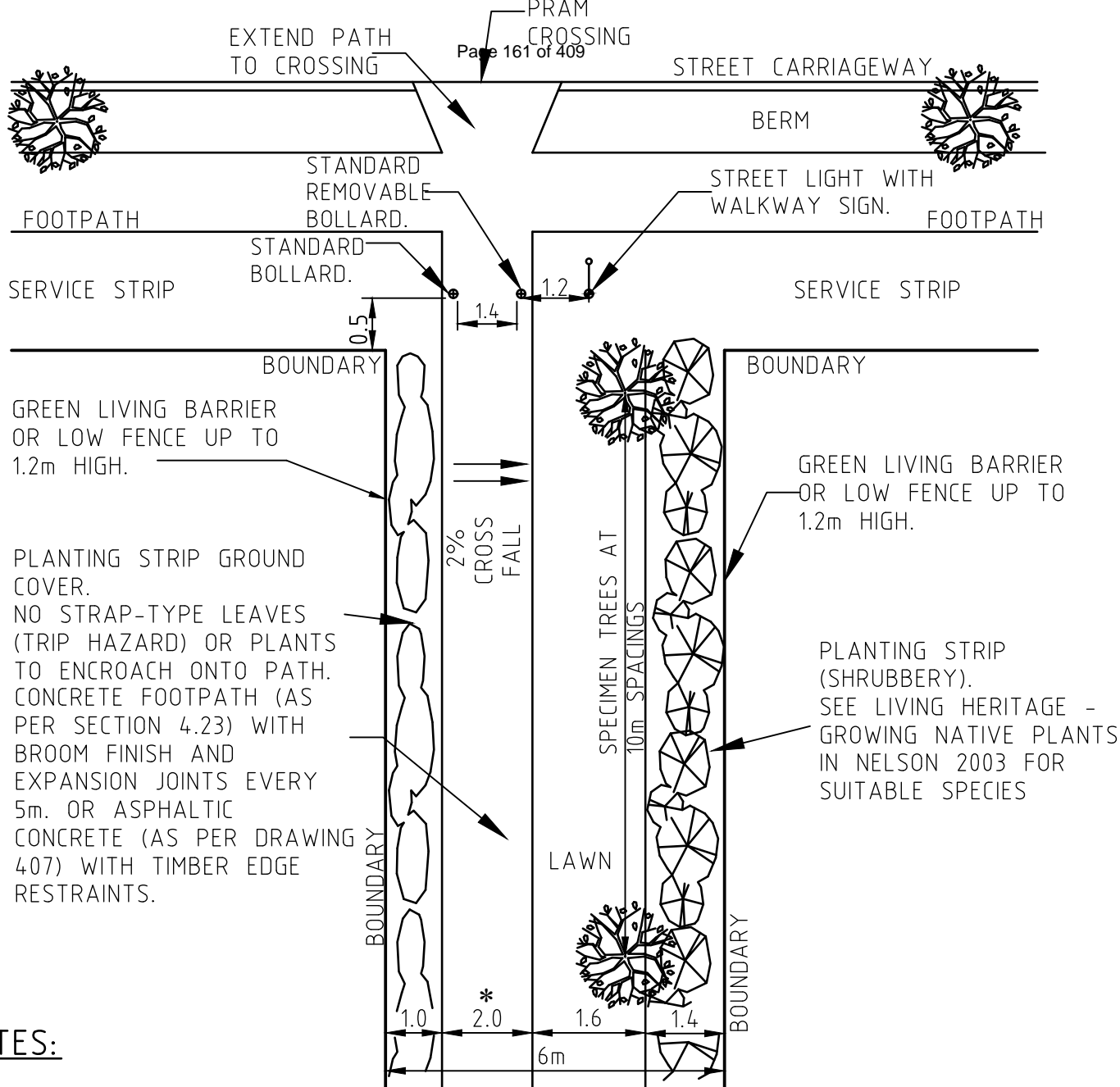

NOTES:

1. * THE PEDESTRIAN/CYCLE ACCESS IS TO BE USED TO LINK A ROAD TO A ROAD OR ROAD TO RESERVE. FOR SHARED ACCESSWAYS THAT ARE ON A MAIN ROUTE & WILL HAVE A HIGH USE, THEN THE SEALED PATHWAY SHALL BE 3.0m & SUBJECT TO SPECIFIC DESIGN.
2. WITH WALKWAYS ORIENTED EAST/WEST PLANT TREES ON THE NORTHERN SIDE OF THE FOOTPATH.
3. IF STEPS ARE REQUIRED FOR GRADES GREATER THAN 1:5 THEN BALUSTRADES SHALL BE PROVIDED TO ONE SIDE. ALSO, A HALF-ROUND OPEN CONCRETE CHANNEL SHALL BE FORMED ADJACENT THE STEPS TO ASSIST CYCLE MOVEMENT,
4. STEPS SHALL BE NO NARROWER THAN 300mm TREAD WITH 150-180 RISER. A LANDING SHALL BE PROVIDED EVERY 20 STEPS. NO LESS THAN 3 STEPS SHALL BE PROVIDED IN ANY ONE AREA.
5. FOR BOLLARD DETAILS SEE DRAWINGS 425 & 426
6. STORMWATER CONTROL IN THE FORM OF KERB, CHANNEL AND SUMPS SHALL BE PROVIDED. THIS SHALL BE DETAILED ON THE DESIGN ENGINEERING PLANS AT THE TIME OF APPROVAL.

<p>NELSON CITY COUNCIL</p> <p><i>[Signature]</i></p> <p>GROUP MANAGER INFRASTRUCTURE, NELSON</p>	<p>PUBLIC ACCESSWAY</p>
---	--------------------------------

<p>TASMAN DISTRICT COUNCIL</p> <p><i>[Signature]</i></p> <p>ENGINEERING SERVICES MANAGER, TASMAN</p>	<p>DATE</p> <p>01/07/19</p>	<p>NELSON - TASMAN</p> <p>LAND DEVELOPMENT MANUAL</p>	<p>427</p>
---	-----------------------------	---	-------------------

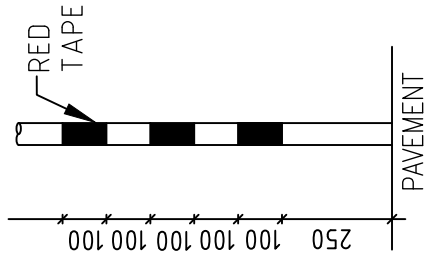

NOTE: USE THIS DETAIL WHEN RAILS ARE WITHIN CARRIAGEWAY AREA AND SEEN BY MOTOR VEHICLES.

NOTE: USE THIS DETAIL WHEN RAILS ARE OUTSIDE CARRIAGEWAY AREA AND SEEN BY CYCLISTS.

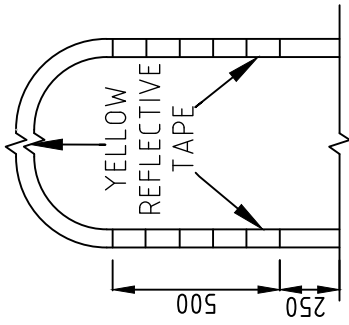

HEIGHT OF RAIL TO BE 1.0m ABOVE ADJACENT CYCLE PAVEMENT AREA.

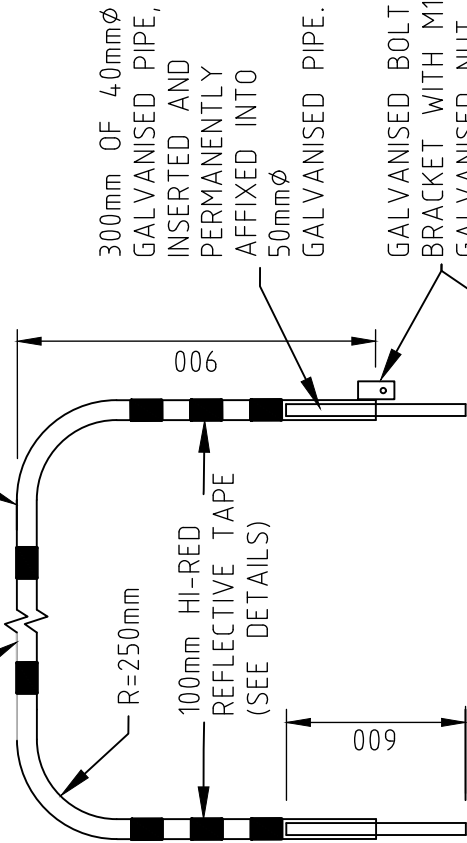

50mm DIA. GALVANISED PIPE PAINTED WHITE WITH APPROVED (EPOXY OR POWDER COATING) SYSTEMS

300mm OF 40mmØ GALVANISED PIPE, INSERTED AND PERMANENTLY AFFIXED INTO 50mmØ GALVANISED PIPE.

200mm Ø CONCRETE SURROUND

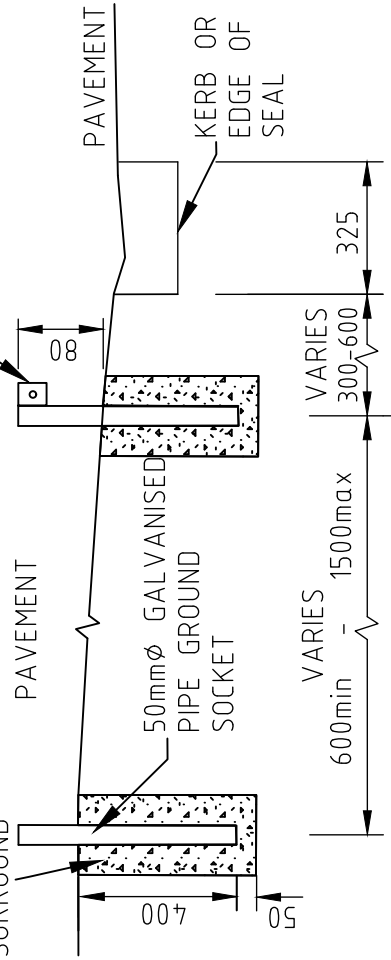

HOLDING RAIL ELEVATION

NOTES:

1. RAIL TO BE PLACED AT EDGE OF CYCLEWAY PAVEMENT OR 300mm FROM EDGE OF PEDESTRIAN REFUGES.
2. TOP RAIL SHALL BE 1.0m ABOVE ADJACENT PAVEMENT

DETAILS

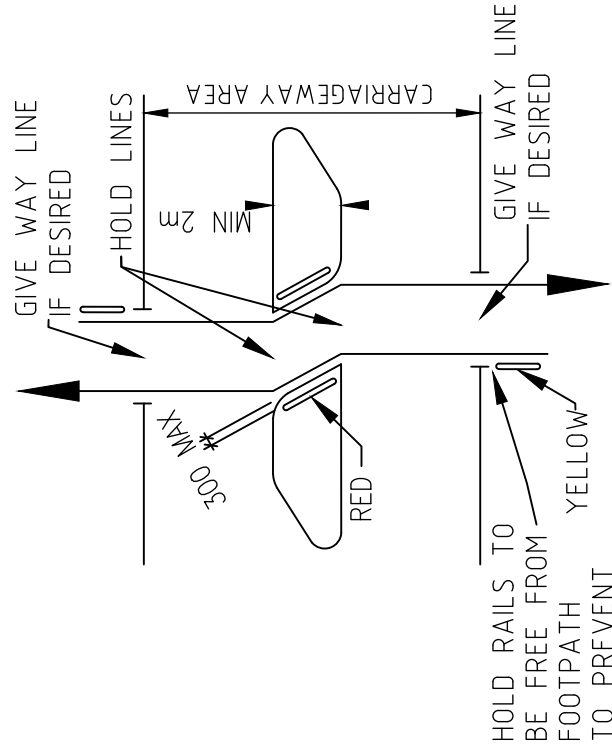

PLAN

NELSON CITY COUNCIL

[Signature]
GROUP MANAGER INFRASTRUCTURE, NELSON

TASMAN DISTRICT COUNCIL

[Signature]
ENGINEERING SERVICES MANAGER, TASMAN

DATE
01/07/19

CYCLE HOLDING RAIL

NELSON - TASMAN
LAND DEVELOPMENT MANUAL

428

NOTES:

SELECTED 1.8m+ TREE GROWN IN A PB90 OR 60 LITRE BAG AND TRAINED AS A STREET TREE. PRUNE TO SHAPE AFTER PLANTING. REMOVE DAMAGED BRANCHES AS REQUIRED.

FOR EXTRA INITIAL SUPPORT THE TREE SHOULD BE TIED IN TWO OPPOSITE DIRECTIONS WITH A SUITABLE LENGTH OF APPROVED TREE TIE.

APPROVED NCC/TDC TREE GUARD PAINTED IN GLOSS BLACK ENAMEL (POWDER COAT).

TREE GUARD BOLTED TO TREE GRATE. DRILL AND TAP GRATE IN WORKSHOP. ENSURE TREE GUARD IS PERPENDICULAR.

2x4 LITRE/HOUR DRIPPER IRRIGATION IF POSSIBLE.

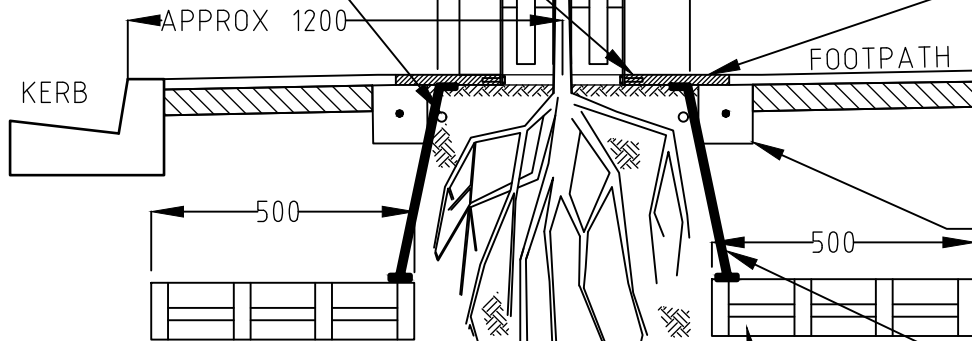

EXCAVATE A ROOT WELL A MINIMUM 500mm BELOW THE ROOT BALL OR DEEPER DEPENDING ON THE HEIGHT OF THE WINTER WATER TABLE. ENSURE THE BOTTOM AND SIDES ARE FREE DRAINING. BACKFILL WITH TOP QUALITY TOPSOIL.

1. TOTAL VOLUME OF ROOT CELLS PLUS ROOT WELL SHALL BE A MINIMUM OF 4m³. UP TO 10m³ MAY BE REQUIRED FOR LARGE TREES TO ENSURE TREE CAN MATURE TO 100 YEAR LIFE MINIMUM.
2. DO NOT APPLY SLOW RELEASE HERBICIDE GRANULES IN THE VICINITY OF STREET TREES.
3. REMOVE BOTH GRATES AND GUARD AFTER 5 YEARS FROM PLANTING.
4. TOP UP TO PATH LEVEL WITH PEA METAL OR SIMILAR.
5. IF IRRIGATION IS NOT AVAILABLE, A 50mm GAP SHOULD BE LEFT BETWEEN THE GRATE AND THE SOIL TO ALLOW A 'WELL' FOR TREE WATERING. THE GRATES WILL BE SUPPORTED BY THE CONCRETE PLANTER.
6. TREE TO BE PLANTED BY EXPERIENCED STAFF. PRUNE ANY DAMAGED ROOTS, AND APPLY SLOW RELEASE FERTILISER.

NCC/TDC APPROVED CAST IRON TREE GRATE SUPPORTED BY FRAME AND/OR CONCRETE SURROUND

150x150 CONCRETE 27.5mPa SURROUND REINFORCED WITH D12 BAR.

PURPOSE MADE PLASTIC ROOT DIRECTOR. MINIMUM 1.0m DIAMETER x 0.75m DEPTH

PURPOSE MADE PLASTIC ROOT CELLS LOADED WITH TOPSOIL. PLACE POROUS GEOTEXTILE ABOVE ROOT CELLS

50/50 MIX OF COMPOST AND GOOD CLEAN TOPSOIL. EVENLY COMPACTED AROUND ROOTS OR ROOT BALL.

NELSON CITY COUNCIL

[Signature]

GROUP MANAGER INFRASTRUCTURE, NELSON

**STREET TREE PLANTER
IN FOOTPATH OR PEDESTRIAN AREAS**

TASMAN DISTRICT COUNCIL

[Signature]

ENGINEERING SERVICES MANAGER, TASMAN

DATE
01/07/19

NELSON - TASMAN
LAND DEVELOPMENT MANUAL

429

SELECTED 1.8m+ TREE GROWN IN A PB90 OR 60 LITRE BAG AND TRAINED AS A STREET TREE. PRUNE TO SHAPE AFTER PLANTING. REMOVE DAMAGED BRANCHES AS REQUIRED.

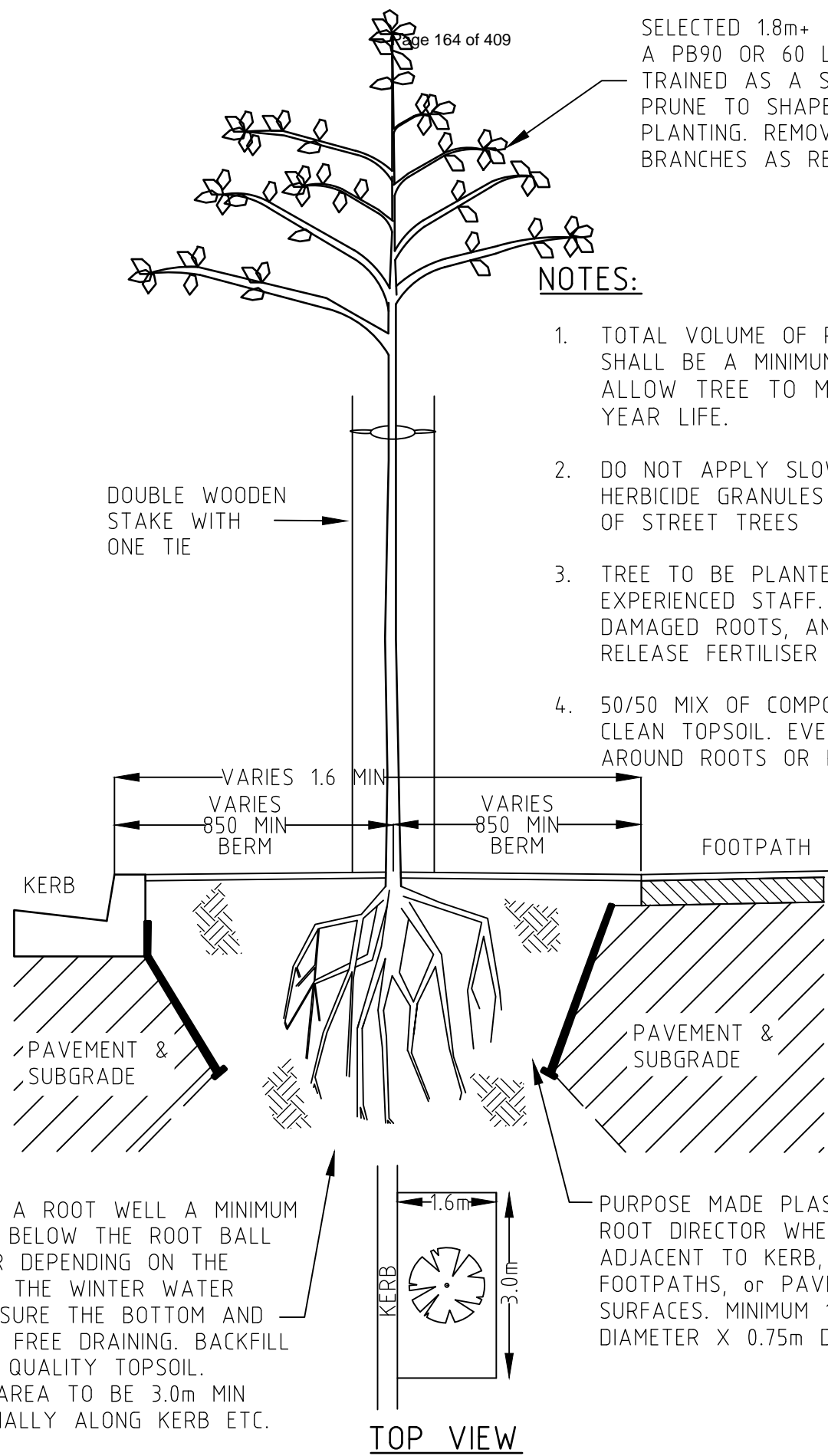

NOTES:

1. TOTAL VOLUME OF ROOT WELL SHALL BE A MINIMUM OF 4m³ & ALLOW TREE TO MATURE TO 100 YEAR LIFE.
2. DO NOT APPLY SLOW RELEASE HERBICIDE GRANULES IN THE VICINITY OF STREET TREES
3. TREE TO BE PLANTED BY EXPERIENCED STAFF. PRUNE ANY DAMAGED ROOTS, AND APPLY SLOW RELEASE FERTILISER
4. 50/50 MIX OF COMPOST AND GOOD CLEAN TOPSOIL. EVENLY COMPACTED AROUND ROOTS OR ROOT BALL

EXCAVATE A ROOT WELL A MINIMUM OF 500mm BELOW THE ROOT BALL OR DEEPER DEPENDING ON THE HEIGHT OF THE WINTER WATER TABLE. ENSURE THE BOTTOM AND SIDES ARE FREE DRAINING. BACKFILL WITH TOP QUALITY TOPSOIL. PLANTED AREA TO BE 3.0m MIN LONGITUDINALLY ALONG KERB ETC.

PURPOSE MADE PLASTIC ROOT DIRECTOR WHERE ADJACENT TO KERB, FOOTPATHS, or PAVED SURFACES. MINIMUM 1.0m DIAMETER X 0.75m DEPTH

TOP VIEW

<p>NELSON CITY COUNCIL</p> <p><i>[Signature]</i></p> <p>GROUP MANAGER INFRASTRUCTURE, NELSON</p>		<p>STREET TREE PLANTER IN BERM</p>	
<p>TASMAN DISTRICT COUNCIL</p> <p><i>[Signature]</i></p> <p>ENGINEERING SERVICES MANAGER, TASMAN</p>		<p>DATE</p> <p>01/07/19</p>	<p>NELSON - TASMAN LAND DEVELOPMENT MANUAL</p>
			<p>430</p>



Chapter 5

Stormwater

TABLE OF CONTENTS

CHAPTER 5 STORMWATER

INTRODUCTION	1
5 PURPOSE	1
5.1 Performance Outcomes	1
5.2 Referenced Documents	2
5.2.1 Resource Management Plans	2
5.2.2 Building Code	2
5.2.3 External Standards	2
STANDARDS	4
5.3 Design Approach	4
Mandatory Matters.....	4
5.3.1 Stormwater effects.....	4
5.3.2 Water sensitive design.....	5
Good Practice	6
5.3.3 WSD device design	6
5.3.4 Catchment Planning	7
5.3.5 Safety in Design.....	7
5.3.6 Durability	8
5.3.7 Ownership and access	8
5.3.8 Easements for stormwater reticulation	8
5.4 System Design	9
Mandatory Requirements	9
5.4.1 System Components	9
5.4.2 Primary Stormwater System.....	9
5.4.3 Secondary Stormwater System	9
5.4.4 Debris flow	11
5.4.5 Freeboards.....	11
5.4.6 Design Standards	12
5.4.7 Stormwater Quality	13
5.4.8 Stormwater Treatment Requirements (water quality).....	13
5.4.9 Stream Bank Erosion Control and Stream Health	15
5.4.10 Infiltration requirements (base flows).....	15
5.4.11 Extended detention requirements (stream bank erosion)	16
5.4.12 Stormwater Quantity Control	17
5.4.13 Detention requirements (Flooding)	17
5.4.14 Detention tanks.....	18
5.4.15 Detention basins, ponds and wetlands.....	18
Good Practice	19
5.4.16 Runoff calculations	19
5.4.17 Rainfall Data	20
5.4.18 Climate change	20
5.4.19 Seismic Design and Liquefaction	20

5.5	Design Solutions	20
	Mandatory Matters.....	20
5.5.1	Open Channel Design	20
	Good Practice	22
5.5.2	Piping of natural watercourses	22
5.5.3	Piped Reticulation	23
5.5.4	Pipe specifications	24
5.5.5	Pipe cover	25
5.5.6	Pipe connections	26
5.5.7	Manholes	26
5.5.8	Pumped stormwater systems	27
5.5.9	Non- pumped pressurised stormwater system	27
5.5.10	Inlets and outlets.....	28
5.5.11	Outfall water levels	28
5.5.12	Culverts	29
5.5.13	Culvert and Sump Blockage	29
5.5.14	Sumps.....	29
5.5.15	Discharge to soakage	31
5.5.16	Access to stormwater features	32
5.6	Construction and Installation.....	33
	Mandatory Matters.....	33
5.6.1	General	33
5.6.2	Health and safety.....	33
5.6.3	Trenching	33
5.6.4	Bedding of pipes	34
5.6.5	Pipe installation.....	35
5.6.6	Manholes and access points	36
5.6.7	Concrete protection for pipes.....	36
5.6.8	Groundwater and trench stops	36
5.6.9	Inspection and Testing.....	37
	Mandatory Matters.....	37
5.6.10	General	37
5.6.11	Closed-Circuit Television (CCTV) Inspection	37
5.6.12	Pressure Testing.....	38

LIST OF TABLES

Table 5-1	Minimum Standards for Stormwater Design, Materials, Construction and Maintenance	2
Table 5-2	Useful references for Stormwater Design, Materials, Construction and Maintenance.....	3
Table 5-3	Effects of Stormwater Discharges	5
Table 5-4	Minimum freeboard requirements.....	12
Table 5-5	Stormwater System Design Capacity Requirements Nelson	13
Table 5-6	First Flush Requirements	14
Table 5-7	Infiltration Requirements.....	16
Table 5-8	Extended Detention Requirements.....	17
Table 5-9	Detention Requirements Summary	17
Table 5-10	Pipe Roughness	23
Table 5-11	Energy Loss.....	24
Table 5-12	Minimum Specification for Public Stormwater Pipes	24
Table 5-13	Pipe Cover Requirements	25
Table 5-14	Required Pipe Access Openings and Limiting Requirements	27

Table 5-15 Required Sump Locations and Limiting Requirements30
Table 5-16 Water Stop Spacing37

LIST OF FIGURES

Figure 5-1 Stormwater control points along the rainfall spectrum (adapted from Clayton & Schuler, 1996 and Auckland Council TR035/2013).....4

CHAPTER 5 STORMWATER

INTRODUCTION

5 PURPOSE

The purpose of this section is to outline standards and good practice matters for the design and construction of stormwater systems for land development and subdivision in the Nelson and Tasman Districts. These aim to achieve flood management, environmental and amenity expectations in an effective and efficient matter. In all situations the provisions of the Nelson Tasman Land Development Manual (NTLDM) are also subject to the applicable Resource Management Plan (RMP).

5.1 Performance Outcomes

The performance outcomes for the design and construction of stormwater systems sought by the standards and good practice matters in this document are as follows:

- a) A management solution that is based on a holistic catchment-based assessment, including consideration of topography, soil and slope, vegetation, built development, existing drainage patterns, freshwater resources, stormwater network infrastructure, natural values and natural hazards;
- b) An integrated design approach to stormwater management, which accommodates stormwater functions including access for maintenance and operations, as well as amenity, recreation and ecological values;
- c) A network that manages stormwater flows to a standard that minimises people and property from harm or damage and nuisance effects, especially from risk to safety, health and well-being;
- d) A management approach that aims to improve water quality;
- e) Devices and design solutions that are robust, durable and easily maintained;
- f) A whole-of-life operations, maintenance and replacement or renewal programme that is clearly described, costed, and can be afforded;
- g) A stormwater system design that takes into account the foreseeable demands of future development;
- h) A resilient network infrastructure that performs well against the risk of geotechnical, seismic, flood hazards and coastal hazards (erosion and inundation);
- i) A design that maintains or improves values associated with freshwater resources, including riparian management and in-stream habitat values;
- j) Stormwater assets that have high amenity value, and shared use of open-space areas where practicable and agreed to by Reserves and Facilities Manager;
- k) A network that maintains a high visual amenity that enhances the value of adjoining property and neighbourhood values as a whole.

All performance outcomes are also subject to the applicable Resource Management Plan objectives and policies and appropriate bylaws, which take precedence over the requirements of the Nelson Tasman Land Development Manual (NTLDM).

5.2 Referenced Documents

5.2.1 Resource Management Plans

The requirements set out in this chapter address matters that are specific to Council asset creation or activities that may have an impact on an asset. They are subject to the Nelson City and Tasman District Resource Management Plans as well as relevant National Environmental Standards and National Policy Statement: Freshwater Management.

5.2.2 Building Code

Stormwater is also regulated within the Building Act and NZ Building Code (NZBC). As part of the building consent application process, stormwater run-off must be addressed by providing appropriate plans and specifications that demonstrate compliance with the performance requirements of NZBC clause E1, “Surface Water”. The information required includes, but is not limited to, the size, fall (gradient) and setting out of the drainage, details of surface water sumps (eg. for drainage of a driveway surface), and provision of access points.

5.2.3 External Standards

In addition to the standards of this document, the standards set out in Table 5-1 also apply unless specified otherwise. Where an Act or National Standards document is referenced, this shall be the current version including any associated amendments.

Table 5-1 Minimum Standards for Stormwater Design, Materials, Construction and Maintenance

Number/Source	Title
NZS4404	Land development and subdivision
AS/NZS1254	PVC pipes and fittings for stormwater and surface water applications
AS/NZS1260	uPVC Pipes and fittings for drain waste and vent applications
NZS7643	Code of Practice for the installation of un-plasticised PVC pipe systems
AS/NZS2032	Installation of PVC pipe systems
AS/NZS2566	Part 1:1998 Buried flexible pipelines – Structural design and Supp 1 Commentary Part 2 – Buried flexible pipelines - Installation
NZS3109	Concrete construction
NZS3121	Water and aggregate for concrete
AS/NZS3725	Design for installation of buried concrete pipes
AS/NZS4058	Pre-cast concrete pipes (pressure and non-pressure)
NZS4442	Welded steel pipes and fittings for water, sewage, and medium pressure gas
Ministry of Business, Innovation & Employment	NZ Building Code – E1 and B2 and associated acceptable solutions and verification methods

Table 5-2 sets out additional and related documents which may be useful references for designers.

Table 5-2 Useful references for Stormwater Design, Materials, Construction and Maintenance

Author / Organisation	Title
Auckland Council	Stormwater management devices in the Auckland region. Auckland Council guideline document, GD2017/001 (GD01)
Auckland Council	Water Sensitive Design for Stormwater, March 2015 Guideline Document 2015/004
Auckland Council	Technical Report TR2013/018: Hydraulic Energy Management - inlet and outlet design for treatment devices
Auckland Council	Technical Report TR2013/040: Stormwater Disposal via Soakage
NIWA	New Zealand Fish Passage Guidelines, for structures up to 4 metres, April 2018
Hamilton City Council	Three Waters Management Practice Notes, Hamilton City Council, HCC01- HCC07
Hamilton City Council	Guidelines – Soak up your Stormwater
Ministry for Primary Industries (MPI)	National Plant Pest Accord (NPPA) List
NZTA	SP/M/022: 2013 - Bridge Manual
NZTA	F2:2013 - Specification for Pipe Subsoil Drain Construction
Water New Zealand	NZ Pipe Inspection Manual 3rd Edition
New Zealand Society of Large Dams (NZSOLD)	Dam safety Guidelines 2015
Christchurch City Council	Waterways, Wetlands and Drainage Guide
Nelson City Council	Nelson City Council/Department of Conservation Living Heritage - Growing Native Plants in Nelson
Tasman District Council	Tasman District Council Native Plant Restoration Lists
Nelson City Council/Tasman District Council	Calculating minimum ground and floor levels for subdivision and new buildings, Tasman District Council and Nelson City Council, Inundation Practice Note 2019.
Nelson City Council/ Tasman District Council	Wetland Practice Note for Nelson City and Tasman District Council 2019 Bioretention Practice Note for Nelson City and Tasman District Council 2019
Landcare	Applying Low Impact Design and Water Sensitive Design in Nelson Tasman, June 2016
Tasman District Council website	Te Tau Ihu Mahi Tuna – Nelson/North Marlborough Eel Management Plan

STANDARDS

5.3 Design Approach

This section outlines the main components of any stormwater network, and applied principles that underpin Council's approach to stormwater management.

Mandatory Matters

The following matters are requirements for the design of stormwater management:

5.3.1 Stormwater effects

- 5.3.1.1 Development effects resulting in changes to stormwater run-off and land drainage patterns shall be managed in accordance with provisions of the applicable Resource Management Plan.
- 5.3.1.2 The design of the total stormwater management approach shall address: adverse effects on water quality; streambank erosion and degradation of stream health; and, increased flood risks.
- 5.3.1.3 The design of the stormwater system shall take into account the variable size and character of storm events, and the differences in environmental effects associated with this, in accordance with Stormwater control points along the rainfall spectrum (adapted from Clayton & Schuler, 1996 and Auckland Council TR035/2013) Table 5-2 and Table 5-3.

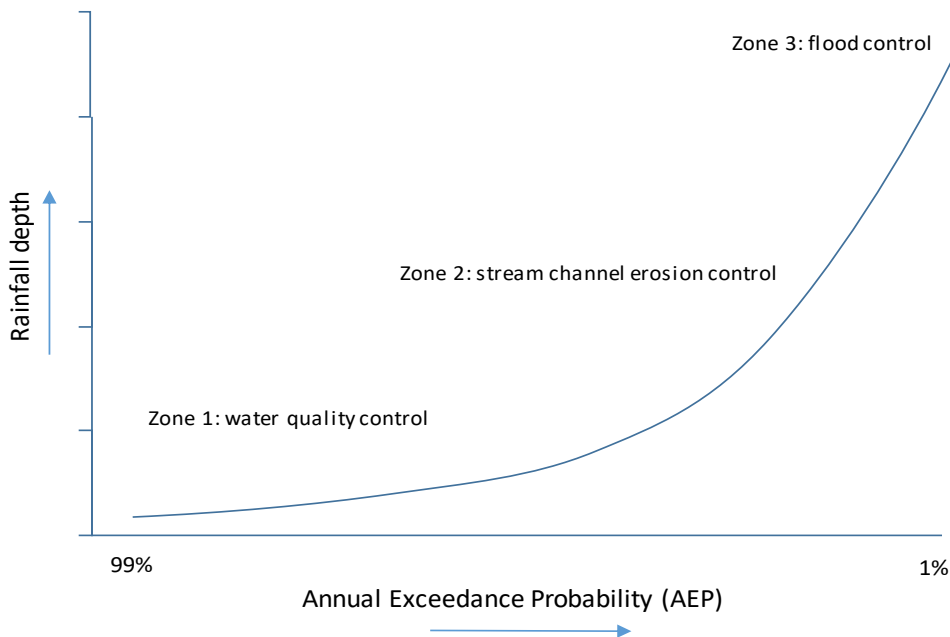

Figure 5-1 Stormwater control points along the rainfall spectrum (adapted from Clayton & Schuler, 1996 and Auckland Council TR035/2013).

Note:

The distribution of rainfall events can be divided into three classes by recurrence interval. The first class has the most frequent rainfall events, which are targeted for water quality control and ground water recharge. Storms in zones two and three are water quantity storms, for which the control objectives are channel erosion and flood control (adapted from Clayton & Schuler, 1996).

5.3.1.4 Table 5-3 sets out the minimum requirements that shall be met to mitigate adverse effects of stormwater discharges.

Table 5-3 Effects of Stormwater Discharges

	Effects on the receiving environment	Resulting from	Required Mitigation
Zone 1	Water quality	Urban land uses such as roading, parking, industrial zones and certain building materials generate contaminants that are picked up by stormwater runoff and accumulate in freshwater and marine water receiving environments	Treatment of stormwater runoff in accordance with Section 5.4.7 and 5.4.8.
Zone 2	Streambank erosion and degradation of stream health	An increase in impervious surface leads to increased runoff volumes and flow velocities during frequently occurring rainfall events. Impervious surface also leads to reduced groundwater recharge and base flows during dry periods.	Infiltration and slowing down flow velocities in accordance with Section 5.4.9 – 5.4.11.
Zone 3	Increased risk of downstream flooding	An increase in impervious surface leads to increased peak flows and flow velocities	Provide detention in accordance with Section 5.4.12 – 5.4.15.

5.3.2 Water sensitive design

5.3.2.1 The design of the stormwater management system shall be consistent with water sensitive design (WSD), using natural processes and soil media to provide sustainable stormwater management.

5.3.2.2 The design shall aim to:

- a) Protect and enhance the values and functions of natural ecosystems;
- b) Address stormwater effects as close to source as possible;
- c) Mimic natural systems and processes for stormwater management;
- d) Support inter-disciplinary planning and design where practicable and;
- e) WSD principles shall be considered during the initial design and planning.

Note:

Effective implementation of WSD principles requires more planning and design input than traditional piped stormwater systems. Good planning and design early in the development process maximises the cost effectiveness of WSD. Further guidance on the implementation of WSD is available in the Auckland Council guideline document GD2015/004 (Water Sensitive Design for Stormwater).

Good Practice

- 5.3.2.3 From the outset, the project team should include a wide range of stakeholders and partners who will be responsible for ensuring the development meets multiple objectives and outcomes.
- 5.3.2.4 Development concepts should be discussed with Council throughout the design process starting at the design concept stage.
- 5.3.2.5 The following process should be followed:
- a) Step 1: Project scoping;
 - i. Identify stakeholders
 - ii. Early consultation with Council
 - iii. Define objectives and outcomes.
 - b) Step 2: Understanding the site's constraints and opportunities;
 - i. Geology, slopes, groundwater, hydrology, zoning, vegetation, cultural values, etc
 - ii. Minimise site disturbance, earthworks and compaction
 - iii. Limit impervious surface
 - iv. Preserve and utilise existing hydrology.
 - c) Step 3: Define stormwater mitigation requirements;
 - i. Identify detention, treatment and stream protection requirements
 - ii. Identify stormwater management solutions and location
 - iii. Identify potential combined functions.
 - d) Step 4: Device design;
 - i. Determine device sizing and footprint of potential stormwater solutions
 - ii. Undertake life cycle costing
 - iii. Iterations and refinements
 - iv. Design preferred stormwater management solution.

5.3.3 WSD device design

- 5.3.3.1 The types of water sensitive devices that could be considered for use include:
- a) Wetlands;
 - b) Vegetated and grassed swales;
 - c) Bioretention (i.e. raingardens, tree pits, infiltration basins);
 - d) Rainwater tanks;
 - e) Permeable paving;
 - f) Green roofs.
- 5.3.3.2 The design of WSD devices should be guided by any of the following guidance documents:
- a) Stormwater management devices in the Auckland region. Auckland Council guideline document, GD2017/001 (GD01);

- b) Hamilton City Council Three Waters Practice Notes: HCC01 to HCC07;
- c) Nelson City Council/ Tasman District Council, Bioretention and wetland Practice Notes, version 1, June 2019.

5.3.3.3 WSD Design Principles

- a) Surface permeability affecting on-site infiltration should be maximised to reduce runoff and optimise groundwater recharge and impervious surfaces should be minimised;
- b) Existing drainage patterns and topographic features, including subsoil features of drainage, should be retained where possible, and restored if degraded through previous development. Stormwater management methods should mimic natural drainage processes where practicable;
- c) Earthworks should be minimised to reduce the potential for erosion, soil compaction and loss of topsoil;
- d) A treatment train approach to stormwater quality should be considered to target specific contaminants of concern. A treatment train may include combinations of on-site mitigation, minimising site disturbance, re-vegetation, instream and riparian habitat restoration, and communal off-site stormwater treatment;
- e) Council may require further details about any device or method used in the proposed stormwater design, including whole-of-life cost implications.

5.3.4 Catchment Planning

- 5.3.4.1 Stormwater management shall be carried out on a holistic catchment or sub-catchment wide basis, rather than for the specific site area only. This includes consideration of topography, existing natural drainage patterns, downstream flooding, soils, vegetation, built development, freshwater resources, stormwater network infrastructure and natural values.
- 5.3.4.2 The stormwater management design shall integrate multiple design factors such as, land-use, roads, access-ways, parks and reserves, ecology, amenity and any other land value associated with the development within the catchment.
- 5.3.4.3 Where a proposed development is in an area covered by a catchment management plan, this shall be considered in the designs. Access to these documents will be made available on the Council's website.
- 5.3.4.4 Any catchment management planning issues, including non-compliance with the catchment management plan, shall be discussed with the Council.

5.3.5 Safety in Design

- 5.3.5.1 The design of all stormwater assets shall consider health and safety risks throughout the life of the asset and shall help to promote the safety of Council employees, contractors and the public.
- 5.3.5.2 Designers of structures are required to consider all aspects of risk during all phases of the asset life, including design, construction, operation and decommissioning and provide a written assessment with the engineering plans. Operational risks shall be considered during both normal use and in extreme storm events.

5.3.5.3 Designers shall ensure that all practicable measures are included in the design to facilitate safe working conditions in and around the asset. As these assets will generally be developed in urban areas, careful consideration is also needed in design and construction with respect to how the public may interact with the asset, to ensure public safety. A written assessment shall be provided with the engineering plans.

5.3.6 Durability

5.3.6.1 All stormwater systems shall be designed and constructed for their ultimate asset life.

5.3.6.2 Designers shall provide whole-of-life costs including capital, maintenance and rehabilitation costs. It is recognised that the durability of individual components may vary, and this should be accounted for in the whole of life cost.

5.3.7 Ownership and access

5.3.7.1 The stormwater system shall generally be in public ownership and on publicly owned land.

5.3.7.2 Ownership of the stormwater network shall be defined as follows:

- a) Private drain – drain serving one property;
- b) Common private drain – drain serving two to five properties;
- c) Public drain – drain serving six properties or more and/or covered by easement in gross or is within road reserve.

5.3.7.3 In planning the layout of stormwater reticulation through private property consideration shall be given to preserving access to the pipelines for:

- a) Maintenance purposes;
- b) Preserving the route for relaying the reticulation in the future;
- c) Avoiding likely positions for buildings, garages, carports and retaining walls; and
- d) Located on the northern side of dwellings.

5.3.7.4 The alignments of stormwater flow paths on private property shall be:

- a) Within ROWs or driveways;
- b) Outside probable building envelopes;
- c) Clear of obstructions;
- d) Adjacent to boundaries – but no closer than 0.6m to outside edge of the pipe or structure;
- e) Parallel to boundaries.

5.3.8 Easements for stormwater reticulation

5.3.8.1 Where as part of a subdivision or development existing and/or proposed public stormwater reticulation will be located in private property an easement shall be required in favour of the Council.

5.3.8.2 The width of easement shall be centred on the centre line of the reticulation and calculated as the general easement width of 3m, plus the diameter of the pipe and the pipe depth of the excavation. (Or at the discretion of the Engineering Manager)

- 5.3.8.3 The standard wording required on the Easement Document shall be:
 “Memorandum Easement in Gross shall be provided in favour of the respective Council to drain stormwater in a pipe and for secondary flow paths and to provide unrestricted access along the line of the pipe for maintenance and renewal work.”

5.4 System Design

This section outlines stormwater system design requirements relating to the key components of the total system and the capacity of them.

Mandatory Requirements

The following matters are mandatory requirements for the design of the stormwater system.

5.4.1 System Components

- 5.4.1.1 The design of the stormwater system shall convey rainfall runoff from the point of interception to the point of discharge to receiving waters or soakage areas.
- 5.4.1.2 The stormwater system consists of a combination of:
- a) Natural systems such as streams (ephemeral, intermittent and permanent) and overland flow paths; and
 - b) Built systems such as constructed channels and drains, piped networks, manholes, inlets/outlets, stormwater quality treatment devices (i.e. wetlands, swales, raingardens etc), detention dams, diversion devices, and pump stations.

5.4.2 Primary Stormwater System

- 5.4.2.1 The primary stormwater systems include both open and closed conduits and shall be designed to cater for the flows generated by the event specified in the design standards in Section 5.4.6 below.
- 5.4.2.2 The location of primary systems shall be aligned with natural flow paths as far as possible.

5.4.3 Secondary Stormwater System

- 5.4.3.1 The secondary system (flowpath) is the route taken by stormwater when the primary system is unable to cope either because of blockages or because the hydraulic capacity of the primary system is exceeded by a larger-than design storm.
- 5.4.3.2 The secondary stormwater system shall consist of ponding areas and overland flow paths with sufficient capacity to transfer the flows generated by the event specified in the design standards in Section 5.4.6 below.
- 5.4.3.3 Secondary flow paths from upstream properties shall be maintained during development processes.
- 5.4.3.4 The effects of flows in excess of the design capacity shall be considered and minimised as far as practically possible.
- 5.4.3.5 For infill and brownfields development where it is unrealistic to provide adequate secondary flow path arrangements through existing downstream urban areas, detention arrangements will be required to supplement available routes in accordance with Table 5-9.

5.4.3.6 Flow paths are to be:

- a) Aligned with natural flow paths wherever possible;
- b) Via roads, public walkways or right of ways wherever possible;
- c) Kept clear of proposed building sites;
- d) Protected by legal easements in favour of Council;
- e) Subject to an encumbrance placed on the title of the land which prohibits ground reshaping and the erection of any barriers to the secondary flows;
- f) Appropriately formed and/or hardened to make their presence obvious and durable;
- g) Designed for public safety.

5.4.3.7 Where roads are designed as part of a secondary flow path, adequate access and egress shall be provided to affected properties without compromising the required flow capacity and in accordance with relevant freeboard requirements.

5.4.3.8 The existing constructed or natural flow paths shall be retained as far as practical. Any alteration of the existing stormwater system shall result in no detrimental impacts to either upstream or downstream properties.

5.4.3.9 Secondary systems shall be located on public land where possible. However, creation of an overland flow path is not to be considered as justification for the land it passes through to be vested in the Council.

5.4.3.10 Where open drains or secondary flowpaths cross private property these will be protected by:

- a) Legal easements in favour of Council and;
- b) Consent notice on the title (top of bank to top of bank) to protect the drain or flowpath from development.

5.4.3.11 The developer shall identify on the engineering plans the location of flowpaths until the point that the flows meet an existing watercourse or discharge point.

5.4.3.12 Public safety shall be incorporated into any design. Where secondary flow paths traverse pedestrian or vehicular accessways or public carriageways, the guidelines is that the expected flow does not exceed the below thresholds:

Pedestrian safety $d_{\text{flow}} \times V_{\text{ave}} < 0.3 \text{ m}^2/\text{s}$

Vehicle safety The height of the total energy line (water level + energy head) shall not exceed 300 mm above roadway surface at the low point of the cross section.

Flow along the road should not exceed $d_{\text{flow}} \times V_{\text{ave}} < 0.3 \text{ m}^2/\text{s}$, except with specific floodway design and additional protection.

Where:

d_{flow} = flow depth in the channel adjacent to the kerb, eg, measured from the invert of the channel (m).

V_{ave} = average flow velocity of the flow (m/s).

Note:

- A maximum depth is required for vehicle safety because small cars can float in depths exceeding 300mm.

- Any sites that do not comply with the above thresholds require approval from the Engineering Manager and shall be clearly identified on engineering plans.

5.4.3.13 Freeboard shall be provided for secondary flowpaths in accordance with 5.4.5.5.

5.4.3.14 Secondary flowpaths shall not be piped due to the risk of blockages. Piping may only be used where no other option exists and are subject to specific approval of the Engineering Manager.

5.4.4 Debris flow

5.4.4.1 Steep (25°-40°) gully catchments shall be assessed by a Chartered Engineer and experienced professional for the risks of debris flows and determining appropriate lateral separation and building freeboard.

5.4.4.2 The design debris flow path shall be based on a 500-year ARI rainfall event. Where these impact on a development site, they shall be shown on engineering plans.

5.4.5 Freeboards

5.4.5.1 Freeboard shall be provided for as a provision for flood level design estimate imprecision, construction tolerances and natural phenomena (eg. waves, debris, aggradations, channel transition and bend effects) not explicitly included in the calculations.

5.4.5.2 The minimum freeboard from the hydraulic grade level of the primary system to the finished ground level shall be 250mm (including for open channels, streams and rivers where the freeboard from the top water level to the top of bank will be 250mm). These figures are a subset of the total freeboard to building platforms as per Table 5-4.

On new subdivisions lot/section, levels (where practicable) shall have the minimum finished ground level being greater than the crown level of the road to which the pipe storm water from the allotment is drained.

5.4.5.3 The minimum freeboard height above the 1% AEP top water level shall be determined as per Table 5-4. The minimum freeboard shall be measured from the top water level to the building platform level or the underside of the floor joists or underside of the floor slab, whichever is applicable.

5.4.5.4 For areas subject to freshwater and tidal inundation, guidance on determining the top water level can be found in the Inundation Practice Note: Calculating minimum ground and floor levels for subdivision and new buildings, Tasman District Council and Nelson City Council, 2019.

Table 5-4 Minimum freeboard requirements

Type of Structure	Freeboard height above 1% AEP top water level
Non-habitable residential buildings and detached garages	0.2m
Commercial and industrial buildings	0.3m
Habitable dwelling (including attached garages)	0.5m
Major community facilities related to supply of electricity, telecommunications, water supply or wastewater disposal	0.6m
Bridges and buildings over watercourses (freeboard to underside of structure)	0.6m

Note:

- i) Structures need to comply with freeboard requirements of the NZ building code and those may be separate from and in addition to freeboard requirements in Table 5-4.
- ii) Specific freeboard requirements apply to areas that are at risk of coastal inundation and shall be in accordance with Inundation Practice Note: Calculating minimum ground and floor levels for subdivision and new buildings, Tasman District Council and Nelson City Council, March 2019.
- iii) Any proposed deviation from the freeboard requirements in Table 5-4 shall be approved by the Engineering Manager.

5.4.5.5 The minimum freeboard for secondary flow paths shall be as per NZ Building Code section 4.3.1 of E1/VM:

5.4.5.6 The floor level shall be set at the height of the secondary flow generated by the 1% AEP flood event plus an allowance for freeboard. The freeboard shall be:

- a) 500mm where surface water has a depth of 100mm or more and extends from the building directly to a road or carpark, other than a carpark for a single dwelling.
- b) 150mm for all other cases

Note:

The 500mm freeboard allows for waves generated by vehicles. Such waves will not be sustained unless there is at least 100mm depth of water and an unobstructed path from the point where the wave is generated to the building.

5.4.6 Design Standards

5.4.6.1 The design of the stormwater system shall cater for the design storms of at least the Annual Exceedance Probability (AEP) as shown in Table 5-5.

Table 5-5 Stormwater System Design Capacity Requirements Nelson

	Nelson City Council	Tasman District Council
Primary systems: stormwater - pipes culverts and open channels	6.67% AEP + climate change (15-year ARI)	10% AEP + climate change (10-year ARI)
Flood Management - streams and rivers	1%AEP + climate change (100-year ARI)	1% AEP + climate change (100-year ARI)
Secondary systems	1% AEP + climate change (100-year ARI)	1% AEP + climate change (100-year ARI)
Dam spillway failure and freeboard sensitivity analysis	Probable Maximum Precipitation (PMP).	

5.4.6.2 Primary and secondary systems shall be designed taking into account the effects of climate change as expected in 2090 based on climate change scenario RPC 8.5 (Representative Concentration Pathway).

5.4.6.3 It is the discretion of the Engineering Manager to require a higher or lower design standard than the standards set out in Table 5-5 in certain occasions or for specific locations. The Engineering Manager will inform designers of any specific requirements outside the above standards. (eg. where the downstream network has a greater design capacity)

5.4.7 Stormwater Quality

5.4.7.1 The effects of development on stormwater quality associated with urban land uses such as roading, parking, industrial zones and certain building materials shall be mitigated.

5.4.7.2 Quality control shall mitigate the effects of contaminants that are picked up by stormwater runoff and accumulate in fresh water and marine water receiving environments. The main contaminants of concern include sediment (total suspended solids), heavy metals (Zinc, Copper, and Lead), and hydrocarbons (oils and grease).

5.4.8 Stormwater Treatment Requirements (water quality)

5.4.8.1 Stormwater treatment shall be provided within greenfield, infill and brownfield developments, including any re-development of roads and parking areas that meet the treatment requirement in 5.4.8.2.

Note:

Redevelopment of roads and parking areas is defined as works that involve the reconstruction and redesign of the road carriageway or parking area to allow for an increased capacity. It does not include isolated maintenance or restoration works such as resurfacing.

5.4.8.2 Stormwater treatment is required for all stormwater runoff that originates from a high contaminant generating surface, including:

- All State Highways, Arterial and Principal roads;
- Collector roads with an actual or forecast average annual daily traffic (AADT) of greater than 5,000 at full development;
- Parking areas, exposed to rainfall, greater than 1,000m² total surface area or more than 50 (AADT), including access ways;

- d) All roads and paved areas (including metaled surfaces) within new industrial and commercial developments;
- e) Service stations;
- f) Unpainted or treated building materials such as copper or zinc roofing.

5.4.8.3 Stormwater treatment is not required for runoff from the following surfaces:

- a) Local access roads and cul-de-sacs within residential developments with AADT less than 5000 at full development;
- b) Parking areas smaller than 1,000m² or less than 50 AADT;
- c) Footpaths and cycle paths;
- d) Metaled roads;
- e) Patios;
- f) Sport fields;
- g) Any pervious surface, including pervious pavement.

5.4.8.4 Treatment devices shall be sized to treat first flush only in accordance with Table 5-6.

Table 5-6 First Flush Requirements

Device type	First flush treatment requirement
Volume based treatment device	25mm of rainfall depth from the total area of high contaminant generating surface
Flow based treatment devices	10mm/hour of runoff from the total area of high contaminant generating surface.

5.4.8.5 Source control shall always be considered and implemented in combination with required stormwater treatment.

5.4.8.6 Appropriate stormwater treatment shall be selected based on water sensitive design principles and designed for on specific land use, associated contaminants of concern and site constraints. Any treatment device shall be designed in accordance with one of the following accepted guidance documents:

- a) Stormwater management devices in the Auckland region. Auckland Council Guideline Document, GD2017/001 (GD01);
- b) Hamilton City Council, Three Waters Management practice notes HCC01 – HCC07;
- c) Nelson City Council/Tasman District Council, Bioretention and Wetland Practice Notes, 2019.

5.4.8.7 Areas with increased risk for oil and or petroleum spills, such as service stations and truck stops shall be designed in accordance with: Ministry for the Environment (MfE) – [Environmental Guidelines for Water Discharges from Petroleum Sites in New Zealand, December 1998, ref no. ME300.](#)

5.4.8.8 Proprietary devices are only allowed when water sensitive design solutions are demonstrated not to be feasible.

- 5.4.8.9 Proprietary devices shall be designed in accordance with the manufacturer's specification and proven to be able to achieve the same outcome as devices designed in accordance with any of the accepted guidance documents.
- 5.4.8.10 In general, the use of proprietary treatment systems in greenfield developments shall not be accepted for vesting in Council ownership.
- 5.4.8.11 A cost benefit analysis, including whole-of-life costs and Council's written approval is required for all devices before vesting.

Good Practice

- 5.4.8.12 Selection and design of appropriate stormwater management devices, including their location should be based on a whole of catchment analysis and aimed at combining multiple functions to achieve the best environmental outcome (i.e. water quality treatment, detention, infiltration, ecology and amenity values)
- 5.4.8.13 Enhanced water quality treatment is considered good practice and can be achieved through:
- Designing for treatment of contaminants in addition to the key contaminants of concern (5.4.7.2), including temperature increases, nutrients, gross pollutants and some household contaminants.
 - Designing for treatment of runoff from surfaces in addition to high contaminant generating surfaces (5.4.8.2) such as lower hierarchy roads (< 5,000 AADT) and small carparks (<1,000m²), driveways and patios.
 - Implementation of catchment devices such as wetlands.
 - Education and increased awareness through signage.

5.4.9 Stream Bank Erosion Control and Stream Health

- 5.4.9.1 Existing freshwater resources, such as streams and wetlands shall be maintained or enhanced through development. This shall include riparian and in-stream habitat values. Any effects from development on streams and stream health shall be avoided as far as practicable.
- 5.4.9.2 Rock lining or other artificial lining, including the use of geotextiles to manage streambank erosion, is not considered appropriate mitigation of effects and shall be avoided when possible. Appropriate erosion and scour protection may still be required at specific locations, such as steep catchments and stormwater outlets.

Note:

Design considerations for soft engineering are site-specific and their implementation should be carefully considered on a case-by-case basis.

- 5.4.9.3 The effects from development and stormwater discharge on stream bank erosion and stream health shall be mitigated through a combination of:
- a) Infiltration of stormwater into the ground and;
 - b) Extended detention.

5.4.10 Infiltration requirements (base flows)

Infiltration is an integral part of natural drainage processes and shall be integrated into the design of the stormwater system. Infiltration reduces stormwater runoff and contributes to groundwater recharge and

base flows in streams. Infiltration of stormwater for greenfield, infill and brownfield developments shall be provided in accordance with Table 5-7 below.

Table 5-7 Infiltration Requirements

Situation	Infiltration requirements
Development, greenfield, infill or brownfield that creates no additional impervious area or where impervious surface is reduced.	None required.
Development, greenfield, infill or brownfield, located outside groundwater recharge zones*.	None required.
Development, greenfield, infill or brownfield, creating additional impervious surface greater than 50m ² and is located within groundwater recharge zones*.	<p>A minimum of 5 mm of runoff from the newly created impervious surfaces* shall be infiltrated within 24 hours to offset the loss of the initial abstraction of 5 mm of rainfall that uncompacted pre-development pervious areas have.</p> <p>*If at the time of consent application, the total newly created impervious surface is unknown, the developer should take into account an estimated total new impervious surface, based on the anticipated future use of the site and maximum allowable coverage percentage under the relevant zoning rules.</p>

Note:

* Recharge zones are defined as:

- i) Areas that are identified as having low risk for slope stability issues;
- ii) Areas with a permeability rate of at least 5mm/hr (as determined through permeability test method described in in E1/VM1 Section 9.0); and
- iii) Areas with a seasonal high ground water table no less than one meter below the surface.

5.4.10.1 Where infiltration is proposed in excess of the 5mm, this is encouraged provided that suitability of the site is proven through permeability testing and the infiltration system is designed with an overflow into the primary stormwater network in accordance with 5.5.15.

5.4.11 Extended detention requirements (stream bank erosion)

Extended detention is required to detain and slow down flows from frequently occurring storm events. Extended detention of stormwater for greenfield, infill and brownfield developments shall be provided in accordance with Table 5-8 below.

Table 5-8 Extended Detention Requirements

Situation	Extended detention requirements
Development, greenfield, infill or brownfield, which does not create a direct discharge into a stream or open drain.	None required.
Development, greenfield, infill or brownfield, creating additional impervious surface greater than 50m ² and a new and direct discharge point into a stream or open drain (lined or unlined).	Implement extended detention according to the following: <ol style="list-style-type: none"> i) Provide storage of the extended detention volume (EDV) that is the equivalent of a 50% AEP event with a two-hour duration, slowly release over 24-hours. ii) Any volume that is infiltrated on site may be subtracted from the extended detention volume.

5.4.12 Stormwater Quantity Control

5.4.12.1 The effects of development on stormwater flows and flooding associated with increased levels of impervious surface shall be mitigated.

5.4.13 Detention requirements (Flooding)

5.4.13.1 Stormwater runoff shall be detained to mitigate the effects of any additional volume or peak discharge rate that would otherwise result from the development.

5.4.13.2 Detention for greenfield, infill and brownfield developments shall be provided in accordance with Table 5-9.

Table 5-9 Detention Requirements Summary

Situation	Detention requirements
Development, greenfield, infill or brownfield that generates no additional impervious area.	None required.
Development, greenfield, infill or brownfield, where the downstream network has sufficient capacity for the increased flows (based on maximum probable development of the catchment) and/or where there are no existing flood risks that would be increased as a result of the development.	None required. (Network capacity to be confirmed by Council where known).
Greenfield development that results in additional impervious surface, where the downstream receiving network has insufficient capacity for the increased flow (based on maximum probable development of the catchment) and/or where there are known flood risks downstream.	Provide detention so that post development peak flows shall not exceed pre-development peak flows for the 10% AEP (10-year ARI) and 1% AEP (100-year ARI).
Brownfield and infill development that results in additional impervious surface, greater than 50m ² where the downstream receiving network has insufficient capacity for the increased flow (based on maximum probable development of the catchment) and/or where there are known flood risks downstream.	50 litres/m ² of additional impervious area. Minimum 20mm orifice for detention up to 5000 litres. Otherwise drain in no less than 24 hours

5.4.14 Detention tanks

- 5.4.14.1 Detention tanks shall be designed in accordance with one of the following accepted guidance documents:
- a) [Stormwater management devices in the Auckland region. Auckland Council Guideline Document, GD2017/001 section C5.0.](#)
 - b) [Hamilton City Council, Three Waters Management practice note, HCC06.](#)
- 5.4.14.2 Where detention tanks are to be used to meet detention requirements, these shall be placed above ground to allow for easy inspection and maintenance (i.e. clearance of blockages), unless performance criteria can be met otherwise and design is approved by the Engineering Manager.

5.4.15 Detention basins, ponds and wetlands

- 5.4.15.1 Detention basins, ponds and wetlands shall be designed in accordance with the following guidance: *Stormwater management devices in the Auckland region. Auckland Council Guideline Document, GD2017/001 sections C8.0 and C9.0.*
- 5.4.15.2 Where detention is formed by a dam structure, a design and construction certificate shall be provided for each structure by a suitably experienced Chartered Professional Engineer stating that the dam has been designed and constructed in accordance with the appropriate requirements NZSOLD Dam Safety Guidelines 2015 and under the Building Code.
- 5.4.15.3 The spillway shall be capable of passing the Probable Maximum Precipitation (that the catchment would discharge into the structure) without risk of overtopping the structure or eroding the spillway.
- 5.4.15.4 Detention basins, ponds and wetlands shall comply with the requirements of Chapter 10 Parks and Reserves and shall be subject to the approval of the Engineering Manager prior to vesting.
- 5.4.15.5 Detention basin design shall mitigate any actual or potential adverse effects by addressing the following points:
- a) Side slope stability and safety considerations;
 - b) Ease of access and maintenance, including mowing and silt cleanout;
 - c) Shape and contour for amenity value;
 - d) The effectiveness of the inlet and outlet structure;
 - e) Secondary overflow options;
 - f) Dam or bank failure;
 - g) Silt traps;
 - h) Fish passage, habitats and birdlife enhancements;
 - i) Road frontage of not less than 30m width;
 - j) Pedestrian links to other reserves;
 - k) Safety fencing;
 - l) Vegetation islands, shading.
- 5.4.15.6 An all-weather access track shall be provided from legal road reserve to the basin, forebay and intake structures. The track shall be no steeper than 1-in-7 (steeper gradients up to 1-in-5 may

be permitted if provided with permanent sealed surface), have a physical width of not less than 3.0m and be provided with stormwater control.

Good Practice

- 5.4.15.7 Where on-site detention tanks are to be used, these can be designed as dual-purpose tanks with the lower two-thirds of a tank being used for stormwater reuse and the top one-third of the tank for detention. Guidance on reuse and dual-purpose tanks is provided in:
- [Stormwater management devices in the Auckland region. Auckland Council Guideline Document, GD2017/001 section C5.0.](#)
 - [Hamilton City Council, Three Waters Management practice note, HCC05.](#)
- 5.4.15.8 Large communal detention structures have the potential to address multiple values at a catchment wide scale such as water quality, ecology and amenity. Because of these additional values, wetlands are preferred over ponds and dry detention basins.

5.4.16 Runoff calculations

- 5.4.16.1 The determination of design stormwater runoff lies with the designer of the proposed network. Calculation of runoff for design shall be determined using an appropriate, recognised, fit for purpose design methodology. The process shall be undertaken or overseen by a suitably qualified and experienced person.
- 5.4.16.2 All underlying assumptions used in the calculations shall be provided for review and approval
- 5.4.16.3 The Rational Method shall be accepted for runoff calculation from catchments smaller than 10 ha. For larger or complex catchments or where significant detention elements are incorporated in the design, runoff shall be determined using an appropriate hydrological and/or hydraulic model to the approval of council.
- 5.4.16.4 The Rational Method formula is: $Q = CIA \times 2.78$.
- Q = runoff.
 - C = runoff coefficient.
 - I = rainfall intensity.
 - A = area of catchment.
- 5.4.16.5 Appropriate runoff coefficients shall be used in accordance with the Building Code Clause E1 Surface Water, verification method 1, table 1.
- 5.4.16.6 Calculation of the time of concentration may be made explicitly, through the use of manual calculations, or via a hydrological / hydraulic model. Designers shall refer to Section 2.3 of Building Code Verification Method E1/VM1 for guidance in the calculation of the time of concentration. Note the time of concentration should be no less than 10 minutes.
- 5.4.16.7 Runoff methodologies developed for specific areas, such as Auckland Council's TP108, may not be appropriate and require approval from the Engineering Manager before being utilised. In all cases all underlying assumptions used in the calculations shall be stated.

5.4.17 Rainfall Data

- 5.4.17.1 Rainfall Intensity or rainfall depths for system design shall be sought from the NIWA HIRDS [website](#) (with allowance for climate change based on RCP8.5 scenario in year 2090. Copies of the data shall be submitted with design calculations.
- 5.4.17.2 In large or flat catchments, the critical rainfall intensity is likely to vary for different sections of the system and should be determined using the time of concentration at the particular point being considered.

5.4.18 Climate change

- 5.4.18.1 The stormwater system shall account for climate change, which is projected to alter the intensity and frequency of significant rainfall events.
- 5.4.18.2 Hydrological calculations shall be carried out with allowances for climate change effects, using a temperature increase of 2.6 degrees by 2090 (based on RCP 8.5).
- 5.4.18.3 In low-lying coastal areas mean sea levels will also affect rivers, streams and stormwater outfalls. The performance of stormwater systems in these areas shall take into account higher predicted sea levels.

5.4.19 Seismic Design and Liquefaction

- 5.4.19.1 All pipes and structures shall be designed with adequate flexibility and provisions to minimise risk of damage during earthquakes.
- 5.4.19.2 Specially designed flexible joints shall be provided at all junctions between pipes and rigid structures (such as reservoirs, pump stations, bridges, and buildings) in natural or made ground.
- 5.4.19.3 In liquefiable prone areas, a geotechnical investigation will be required. The geotechnical investigation will need to assess the potential of the ground to liquefy under seismic loading and assess the likely effects of liquefaction on buried infrastructure. The assessment will be conducted in accordance with New Zealand Geotechnical Science guidance: Guideline for the identification, assessment and mitigation of liquefaction hazards.
- 5.4.19.4 In areas where there is a potential for liquefaction to impact upon buried infrastructure the network must be designed with special provisions to minimise the risk of damage during an earthquake.

5.5 Design Solutions

The following standards relate to the design of specific solutions used in the management of stormwater.

Mandatory Matters

These standards are requirements for the design of specific stormwater management solutions.

5.5.1 Open Channel Design

- 5.5.1.1 Open channels in stormwater systems shall be considered as receiving environments protected under the Resource Management Plans (regardless of modification).
- 5.5.1.2 The following functions shall be addressed in the design of open channels:

- a) Secondary flow corridors to carry the 1% AEP flows;
- b) Recreational spaces for the community;
- c) Habitat for aquatic flora and fauna to promote biodiversity;
- d) Open channels shall be designed with appropriate riparian vegetation cover and incorporate natural features such as meanders, ponds and riffles, native plants, shading, fish passage and refuge, invertebrate and bird habitat;
- e) The design shall include maintenance access without compromise of the riparian and in-stream ecological values. Additional land will be required to avoid this compromise;
- f) The design of open channels based on Manning's Formula calculations is acceptable unless unusual circumstances exist. Full details of the associated assumptions and calculations shall be presented to Council.

Mannings formula is $Q = (AR^{2/3} S^{1/2}) / n^*$

where:

Q = flow m³/s

R = hydraulic radius (m)

S = slope of surface

A = water section area, m².

*n = roughness coefficient

- 5.5.1.3 Capacity calculations for open channels shall include consideration of future vegetation enhancement potential, making allowance for mature riparian vegetation and natural stream bed and banks in the determination of appropriate Manning's n values (minimum of 0.055).
- 5.5.1.4 Where open channel systems (including artificially formed drains) are to be incorporated in the stormwater drainage system, they shall be located within a Local Purpose (Utility) Reserve of sufficient width to contain the full design flood flow together with freeboard and access track.
- 5.5.1.5 Within urban development sites, where natural open channel areas form part of the consented stormwater drainage system they shall be cleared of all unsuitable plant growth and replanted to an appropriately approved landscape design (See Section 10.6.3 Riparian Plantings).

Good Practice

- 5.5.1.6 In greenfield and brownfield situations where there are existing hardened channels, culverts or piped streams, consideration should be made for day-lighting the stream and the restoration of natural channel meanders to be incorporated in the subdivision layout.
- 5.5.1.7 The stream bed and banks should be designed as an integrated part of development in order to gain ecological, aesthetic, amenity and recreational benefits.
- 5.5.1.8 Council may require an independent assessment by a suitably qualified aquatic ecologist.
- 5.5.1.9 The following design criteria should be considered for aquatic habitat in streams:
- Overhanging vegetation: planting of riparian margins should be aimed at achieving 70% shading of a wetted width of three metres or less after 20 years of tree growth.
 - Meander patterns: the radii and wavelength of stream bends need to be appropriate to the location and simulate natural streams in a similar setting.
 - Bank shape: allow for variety in steeper bank shapes and flatter beach bars as deposition zones for sediment.
 - Water depth: allow for variety of water depths with deep pools and shallower sections such as rapids and riffles.
 - Substrate: Sufficient gravel thickness, cobble and woody debris are essential components for healthy streams.
 - Flood plain: Flat benches that are designed to flood in high flows may also provide for other functions such as spawning sites and capturing sediment that would otherwise clog the channel.

5.5.2 Piping of natural watercourses

- 5.5.2.1 New piping and modification of natural watercourses shall be avoided.
- 5.5.2.2 All continuously flowing, intermittent and ephemeral water courses shall be retained as natural drainage features unless exceptional circumstances exist. The design and layout of a development will therefore need to account for retained water courses, including access and maintenance requirements.
- 5.5.2.3 Where piping of watercourses is justified, due to for example the ongoing maintenance requirements or access restrictions. The following shall apply:
- Resource consent will be required.
 - Pipes shall be used or subsoil drains (Type B) shall be laid at the invert level of the pipe and connected to manholes, to ensure groundwater levels are not forced to rise. Where pipe routes differ from the original stream course, sufficient protection from seepage in the original stream bed shall be provided.
 - Secondary overland flow paths shall be provided as per Section 5.4.

- 5.5.2.4 Where a perennial or intermittent watercourse is replaced with a pipe, allowance shall be made for fish passage, including velocity considerations, and provision of an in-stream environment for pipes longer than 15m consisting of a 100mm to 150mm thick gravel layer.
- 5.5.2.5 The flow velocities shall be limited to the values in Table 5-12. As a minimum, pipes shall be increased one pipe size above that normally required and shall be embedded such that the invert is 50mm below the stream bed and the pipe maintains the same grade as the bed upstream and downstream of the pipe.
- 5.5.2.6 Fish recovery by a DoC permitted operator is required for ponds, watercourses and drainage channels that are filled in over a surface area of 50m² or more.

5.5.3 Piped Reticulation

- 5.5.3.1 Pipe capacity shall meet the appropriate design capacity from Table 5-5.
- 5.5.3.2 In urban areas, pipes shall be aligned within public areas such as road reserves wherever possible and not be placed where buildings will be placed on top.
- 5.5.3.3 In rural areas, the public piped stormwater system shall be aligned in public areas and natural and private stormwater infrastructure shall maintain its current alignment as far as possible.
- 5.5.3.4 Pipes in roads shall be aligned parallel to kerb lines within the carriageway to minimise interaction with other services. Adequate clearance from other services and kerb lines shall be maintained to allow for:
- Excavation on existing services.
 - The future renewal of the assets.
 - The provision of additional future services.
- 5.5.3.5 In curved roads, pipes shall generally follow the road alignment in straight lines between manholes on such alignment that they do not occupy the full carriageway width.
- 5.5.3.6 Diagonal crossings of other roads and services, including kerb lines and boundaries or fence lines, at acute angles less than 45 degrees, shall be avoided wherever possible.
- 5.5.3.7 Pipe sizes and grades shall be calculated using standard hydraulic formulae (Manning, Colebrook-White).
- 5.5.3.8 A pipe roughness equivalent to one of those shown in Table 5-10 shall be adopted to account for velocity head within the pipeline, gravel and grit deposits and other site variables such as construction performance and pipeline deterioration with age. Losses due to bends, manholes and sumps shall be incorporated into the design of pipe systems.

Table 5-10 Pipe Roughness

Method	Pipe Roughness
Mannings formula	$n = 0.013$
Colebrook-White formula	$k_s = 1.5\text{mm}$ up to 450mm pipe $k_s = 0.6$ for over 450mm pipes

- 5.5.3.9 In addition, appropriate allowances shall be made for changes in direction, inlet and outlet losses and obstacles Table 5-11 gives typical energy loss coefficients (k). In addition, changes in hydraulic grade line due to changes in velocity head which shall also be allowed for.

Table 5-11 Energy Loss

Energy loss $h_e = k v^2/2g$ (h in metres, v in m/s)	
Type	K
Sharp pipe entry (from reservoir)	0.5
90° manhole (depending on radius)	0.5 to 1.0
Velocity head loss at outlet	1.0

- 5.5.3.10 Where a pipe gradient exceeds 1-in-10 (10% grade, 5.74 degrees) an allowance for the bulking of the flow due to air entrainment shall be made by multiplying the area of the pipe by $(1+kv^2/gR)$.

Where:

- k = coefficient of entrainment (dimensionless)
 = 0.004 for smooth pipes
 = 0.008 for cast-in-situ concrete culverts
- V = velocity (m/s)
- R = hydraulic radius (m)
- g = acceleration due to gravity (9.81 m/s²)

- 5.5.3.11 All piped systems shall be designed to accept existing flows from above a proposed development and shall be of sufficient capacity to provide for the primary flow from maximum probable site development.
- 5.5.3.12 Piped stormwater systems should generally be designed to flow full or part full under gravity at design flows with pipes aligned soffit-to-soffit.

5.5.4 Pipe specifications

Table 5-12 sets out the minimum specifications for public stormwater pipe design.

Table 5-12 Minimum Specification for Public Stormwater Pipes

Aspect	Concrete pipe	uPVC pipe	PE Pipes
Permitted size	Minimum 300mm ID Thereafter in 75mm increments	Minimum DN 300mm ID Maximum DN 500mm ID	Various
Minimum standard	NZS4058	AS/NZS1254	AS/NZS2566
Material strength	Minimum Class 2 and in accordance with AS/NZS3725	Minimum SN 8 Specific design to AS/NZS2566 method for depth >5.0m, or traffic wheel loads >96 kN	Due to the various design applications that PE Pipes can be used in, strength, cover and bedding will be
Cover depth	Refer Table 5-13	Refer Table 5-13	
Joints	Rubber ring jointed		

Aspect	Concrete pipe	uPVC pipe	PE Pipes
Pipe capacity	Refer to Table 5-14		addressed on a case by case basis.
Flow velocity	Minimum 0.75m/s or 0.3m/s in culverts where native fish may be present Maximum 6.0m/s and 0.5m/s at average flow in culverts where native fish may be present		
Pipe location (in preference)	Road reserve		
Clearance from other services	Minimum 200mm vertical Minimum 500mm horizontal (lesser clearance on approval of the Engineering Manager)		
Gravel or silt traps may be required to be installed in low velocity flow situations.			

- 5.5.4.1 Except at intake structures, it will not be permitted to reduce the diameter of pipe even where changes in grade would produce the required capacity in a smaller diameter of the downstream pipe. This is due to the potential for debris/sticks which could enter the system to block at the reduced orifice.

5.5.5 Pipe cover

- 5.5.5.1 Pipe systems shall be designed to ensure the minimum cover over the barrel in accordance with Table 5-13. Generally deep pipelines exceeding 2.5m deep should be avoided. Over-depth pipelines are difficult to access for future maintenance and renewal works.

Table 5-13 Pipe Cover Requirements

Location of Pipe	Minimum Cover Required		
	Concrete Pipe	PVC Pipe	PE Pipe
Areas subject to highway traffic loading eg., within road carriageway	600mm	750mm	Due to the various design applications that PE Pipes can be used in, strength, cover and bedding will be addressed on a case by case basis.
Areas subject to light traffic loading outside road eg. ROWs, driveways, car parks and berms	450mm	600mm	
Areas never subject to traffic loading	300mm	450mm	

- 5.5.5.2 Where pipes with inadequate cover require concrete encasement or capping, the extent, thickness and strength of concrete shall be specified on the drawings.
- 5.5.5.3 To avoid reflective cracking of pavements and differential settlement, concrete encasement and capping shall not be permitted to penetrate the base course or pavement construction.
- 5.5.5.4 No concrete protection shall be placed around the pipe until the line has been inspected and approved to the satisfaction of Council.
- 5.5.5.5 Minimum pipe cover may be reduced subject to approval from the Engineering Manager in the following cases:
- The appropriate class of concrete pipe is specified, and cover is according to the manufacturer's specification. Details of pipe class design shall be determined by use of the

pipe class software (<http://www.cpaas.asn.au/General/design-software-pipeclass.html>) and provided with engineering plans;

- b) Or concrete pipes are concrete encased; or
- c) PVC pipes are concrete capped.
- d) PE pipes will require specific design on a case by case basis.

5.5.6 Pipe connections

5.5.6.1 Piped connections to each site shall meet the following:

- a) In all subdivisions, a stormwater system of a minimum 100mm diameter shall be provided to at least 1.0m inside the boundary of each lot (or body of each lot if served by ROW). Note: The pipe end shall be painted green to denote that it is a stormwater pipe and each connection shall be marked by a 75mm x 25mm marker stake suitably identified.
- b) On generally flat land, sloping at 1-in-50 or less, each connection shall be capable of serving the entire building area of the section by gravity.
- c) On land steeper than 1-in-50 every effort shall be made to serve the entire section. Where this proves to be impossible and the servicing of the site is limited the area on each lot capable of being serviced shall be shown on the Engineering Drawing.

5.5.6.2 In infill situations, Bubble Up discharges may be accepted at the discretion of the Engineering Manager.

5.5.6.3 Kerb entry discharges are generally not permitted. However, where specific approval is given by Council for stormwater disposal via kerb entry, installation requirements will be supplied by staff on a case by case basis.

5.5.6.4 On-site requirements for stormwater management systems, such as special sumps and filters, shall be provided for in accordance with the Building Act and Building Code.

5.5.6.5 Inspection 'T's at lot boundaries will only be required when or where downstream capacity and pipe materials are compromised.

5.5.7 Manholes

5.5.7.1 Table 5-14 sets out the minimum specifications for manholes, mini-manholes and rodding points.

5.5.7.2 Prefabricated PVC or PE mini-manholes shall only be used on approval by Council.

5.5.7.3 Mini-manholes are not to be used in areas subject to vehicular traffic, except where formed in residential driveways or rights-of-ways open to light domestic vehicles. In this instance, they shall be located out of usually trafficked areas.

5.5.7.4 The use of rodding points shall be limited to changes in pipe grade or alignment, at the top of steep banks where installation of a manhole or mini-manhole would not be practicably feasible.

Table 5-14 Required Pipe Access Openings and Limiting Requirements

Aspect	Manholes	Mini-manholes	Rodding Point
Locations where pipe access shall be provided	Manholes to be provided at: <ul style="list-style-type: none"> - change in size - pipe junctions - at head of Council system - at abrupt changes of grade - 120m max spacing 	Mini manholes may be provided at private connections, out of areas subject to heavy traffic loading.	Rodding point may be used at change in grade or alignment on steep sections where manhole would not be practicably feasible.
Maximum pipe size	Up to 450mm pipe = 1050 mm manhole Up to 750mm pipe = 1350 mm manhole Up to 1050mm pipe = 1500 mm manhole 1200+mm pipe = manhole of 1.5 x pipe diameter*	225mm ID	225mm ID
Maximum depth	2.5m	1.0m for public pipe	2.5m
Minimum fall through manhole	50mm	50mm	
Maximum deflection angle	90° for pipe to 375mm 60° for pipe >375mm	45°	90°
Approved materials	Concrete**	PVC, PE Concrete	uPVC
Standard Drawing	513	604	609 - 610

*Factory-made "T" manholes will be permitted for pipes of 1350mm diameter and over, subject to the approval of Council.

Design shall be generally consistent with Concrete Pipe Association of Australasia (CPAA) Guidance Note

5.5.8 Pumped stormwater systems

5.5.8.1 Stormwater pumping is not permitted, unless specifically approved by the Engineering Manager.

5.5.9 Non- pumped pressurised stormwater system

5.5.9.1 A non-pumped pressurised stormwater system shall be subject to the Engineering Manager's approval.

5.5.9.2 Where a non-pumped pressurised stormwater system is deemed to be necessary the hydraulic grade line shall be plotted on the longitudinal section. Reduced levels and the hydraulic gradient shall be quoted for the entire length of the pipeline. In no cases shall the hydraulic grade line be above finished ground level.

5.5.9.3 Adequate provision shall be made in the design for air release to minimise dangerous pressures or excessive noise.

5.5.10 Inlets and outlets

- 5.5.10.1 Every inlet to a piped stormwater system shall be provided with a suitable inlet structure and grill.
- 5.5.10.2 The minimum height of headwall above the design stream flow shall be 300mm. Note: any drop height of 1.0m or more will need appropriate fall protection installed.
- 5.5.10.3 Stormwater outlets shall be designed in accordance with SD503 – SD505.
- 5.5.10.4 Structures are to be constructed in precast reinforced concrete and modified to provide an aesthetically pleasing appearance suitable to the particular site.
- 5.5.10.5 Structures are to be constructed to allow fish passage.
- 5.5.10.6 Refer to SD518 and SD519 for details of the Standard Sump. (For use as a minor intake only and where the risk of blockage is minimal.)
- 5.5.10.7 When designing inlets to culverts, debris screening may be required. The need for debris screens or grilles will be subject to specific design, taking into account the likelihood of debris flowing from the upstream catchment and potential impact on the culvert.
- 5.5.10.8 Culvert inlets are not generally screened for safety reasons. However, a risk assessment shall be undertaken on each culvert (and the surrounding catchment) to ascertain if a grille is required to prevent accidental entry to the culvert. If a grille is required, provision shall be made for the effects of debris build-up against that grille.
- 5.5.10.9 There shall be suitable access for maintenance personnel and for any mechanical plant required to remove debris build-up from the grille.
- 5.5.10.10 Pipeline and culverts requiring an inlet structure shall take account of the inherent hydraulic losses associated with flow transition to ensure the inlet is appropriately sized to convey the design flow without heading up and overtopping and blockage as per Section 5.5.13.
- 5.5.10.11 Modified intakes will be required at specific locations to provide additional protection to the pipe inlet against the risk of blockage by solids and floating debris. SD506 – SD510 provide details of general examples of deep trap sumps and railway iron trash racks and sump. Each case will require specific design to suit the site with regard to peak flows, secondary intakes, expected debris and access for maintenance. Final details shall be submitted to the Council for approval.
- 5.5.10.12 In the case of a temporary intake, the structure shall be adequate for the estimated period before the permanent extension. Temporary intakes and outlets shall be designed to cope with individual requirements including fish passage.

5.5.11 Outfall water levels

- 5.5.11.1 Where a pipeline or waterway discharges into a much larger system, the peak flows generally do not coincide. Backwater profiles should produce satisfactory water levels when assessed in accordance with method NZS4404 – clause 4.3.9.8.

5.5.12 Culverts

- 5.5.12.1 Culverts shall be of sufficient strength to support all designed superimposed loads in accordance with NZS/AS 3725 and culvert design manuals. Note – minimum 375mm diameter for rural access crossings.
- 5.5.12.2 Culverts shall have adequate wingwalls, headwalls, aprons, approved grills, traps and/or pits to prevent blockage, scouring and erosion.
- 5.5.12.3 Inlets shall be designed to ensure adequate intake capacity and provide headwalls no lower than maximum surcharge levels.
- 5.5.12.4 Any headwall above a drop of greater than 1m shall have barriers complying with the Building Code.
- 5.5.12.5 Sufficient erosion protection shall be provided in the event of flow over an embankment.
- 5.5.12.6 Culverts shall allow for fish passage designed in accordance with the [NZ Fish Passage Guideline](#).

5.5.13 Culvert and Sump Blockage

- 5.5.13.1 For pipe sizing a blockage factor of 10% shall be allowed for culverts of less than 3.0m dimension.
- 5.5.13.2 System blockage shall be considered in the design of the system and documented for all designs and a secondary flow path shall be kept unobstructed at all times.
- 5.5.13.3 The secondary flow path design shall assume the total blockage of the culvert where it is less than 1500mm and 50% blockage of the culvert where it is greater than or equal to 1500mm.
- 5.5.13.4 The risk assessment for system blockage shall consider:
 - a) The likelihood of blockage given the availability of debris (including sand for tidal outlets);
 - b) The likelihood of debris transport given the flow path slope and catchment land use;
 - c) The size of openings that may block; and
 - d) The consequences of that blockage including floor level flooding, unsafe flows, excessive erosion, structural damage or damage to historical areas.
 - e) The risk assessment may require allowance for 100% blockage of pipes greater than 1500mm in some circumstances.

5.5.14 Sumps

- 5.5.14.1 Sumps shall be located to ensure that the total system design flow can enter the pipe system and that surface flows across intersections are minimised. In hill areas, the total system design flow will include run-off from any upslope hillsides that are not specifically drained. In many cases this will mean the use of closely spaced sumps or flow diverters to ensure that the flow to which the piped system is designed can actually get into the system.
- 5.5.14.2 Sumps shall be to Council standard in accordance with SD 515 – SD 525 and in accordance with the requirements of Table 5-15. Sumps in cycle facilities shall have cycle friendly grates.

5.5.14.3 The standard sump to be incorporated with all kerb and channel or mountable kerb and channel is the Back-Entry Sump as detailed on SD 515 – SD 517.

Table 5-15 Required Sump Locations and Limiting Requirements

Location	Standard Back Entry Sumps	Standard Back Entry Sumps with flow diverter	Double Back Entry Sump
Approved locations	<p>At each tangent point of the channel on the upstream side of road intersections where the grade is flatter than 1-in-10 (10%, 5.74 degrees).</p> <p>At any low spot in a channel.</p> <p>Serving any right-of-way.</p>	<p>At each tangent point of the channel on the upstream side of road intersections where the grade is equal to or steeper than 1-in-10.</p> <p>Where the channel upslope of the sump is steeper than 1 in 10.</p> <p>Where area of the catchment warrants the provision of adequate stormwater entry.</p>	<p>Where the length of kerb and channel draining to a low point is excessive.</p> <p>At a low point at the head of a cul-de-sac or street where secondary flow paths flow through private property.</p>
Minimum lateral pipe size	225mm ID	225mm ID	300mm ID
Standard Drawing	516 - 519		
Maximum depth	1300mm		
Maximum distance between sumps*	<p>Standard kerb: 100m</p> <p>Mountable kerb: 60m</p> <p>(Subject to specific design on a case-by-case basis)</p>		
Approved materials	Concrete		

Note: Closer spacing of sumps may be required depending on the rate of runoff expected. Sumps shall not be positioned at vehicle crossings or pram crossings.

5.5.14.4 Where a sump unavoidably coincides with a vehicle crossing (and back entry is not feasible) an additional standard (back entry) sump or flow diverter shall be constructed on the upstream side of the crossing and the pipe extended into the sump.

5.5.14.5 The tolerance for the location, alignment and level of a sump shall be as follows:

- Lateral alignment of the sump top shall be within a maximum of plus or minus 10mm of the design line of the kerb and channel.
- The skew of the sump top in relation to the kerb and channel alignment shall be within 10mm of being parallel.
- The sump shall be placed within 20mm of being vertical and 20mm of the millimetres of the maximum depth.
- The finished level of the sump shall ensure compliance with the tolerance requirements for kerb and channel finished level as per the Transportation section of this manual.
- The vertical alignment of kerb and channel shall be designed to ensure that no low point requiring a standard sump will coincide with any kerb and channel curve of less than 50m radius (except at the turning heads of cul-de-sacs).

- 5.5.14.6 Sumps draining private right-of-ways can be provided with a minimum lateral pipe size of 150mm ID subject to suitable catchment design and a secondary flow path being directed to the road carriageway.
- 5.5.14.7 Sumps which are located in tidal areas or in areas subject to flooding may require non-return systems to prevent backflow up the line. Other designs will be assessed on a case-by-case basis.
- 5.5.14.8 Sump connections may be made to the stormwater pipe by use of saddle connections as long as the centreline of the lateral is no lower than the centreline of the larger pipe in accordance with SD 526.

5.5.15 Discharge to soakage

- 5.5.15.1 Where disposal of stormwater to soakage is proposed as the primary form of stormwater disposal or any soakage beyond the minimum recharge requirement of 5mm, then the following details are required and to be prepared by a suitably qualified geotechnical specialist. All details to be submitted to Council for review:
- a) Detailed site-specific geotechnical investigation, including comprehensive soakage testing (in accordance with Auckland Council Technical Report TR2013/040: Stormwater Disposal via Soakage) across the proposed soakage areas.
 - b) An assessment of the predominant soakage paths and soakage rates, both vertical and horizontal that make up the soakage zone and confirm the extent of 'horizontal' soakage and the effects that this may cause on land stability, both of the current and future lot(s) and on any other adjacent property and or existing or future structures that are built or likely to be built within the soakage zone.
 - c) Specific documentation of the likely winter peak groundwater table level.
 - d) Detailed calculations, drawings and field soakage test results
 - e) Device design details for on-site stormwater disposal of primary and secondary flows
 - f) System blockage shall be considered in the design of the system and a secondary flowpath shall be kept unobstructed at all times.
 - g) Stormwater treatment shall be provided in accordance with 5.4.8.
- 5.5.15.2 For any development intended to include privately owned soakage systems, a consent notice or other appropriate legal instrument shall be included on titles.
- 5.5.15.3 Where a Public stormwater system is accessible from the site, the developer shall determine whether the system has sufficient capacity and enquire with Council whether there are any other known constraints.
- 5.5.15.4 Where there are capacity constraints on the existing public system the developer shall provide appropriate detention or remove all the downstream constraints.
- 5.5.15.5 Soakage shall not be constructed within flood plains and overland flow paths shall be provided in accordance with Section 5.4.3.

5.5.16 Access to stormwater features and surface cut-off drains

- 5.5.16.1 Access to Local Purpose (Utility) Reserves, intake and outlet structures, wetlands and other treatment devices and alongside open channels shall always be provided for maintenance and conform with the following requirements:
- a) An all-weather access track for trucks and wheeled excavators.
 - b) Three (3) metres wide for travel able to be accessed by an 8.2t axle weight rigid vehicle for its entire length.
 - c) 4m minimum width where excavators will swivel to access the feature and providing sufficient space for operation of plant to work on the feature.
- 5.5.16.2 Where a feature is greater than 15m wide then access tracks will be required on both/all sides.
- 5.5.16.3 Narrow features (<15m wide) will require a 4m access track on one side and a 1.5m access corridor on the other between the top of bank and the edge of the Council Utility Reserve.
- 5.5.16.4 The access shall not compromise riparian or instream vegetation. Additional land area will be required where there would otherwise be a compromise.
- 5.5.16.5 Where possible, access tracks shall be placed on the east and south sides of narrow features to allow for additional tree planting on the western and northern sides for the purposes of shading.
- 5.5.16.6 Where the access track is greater than 50m in length, a turning area for an 8.2t rigid truck shall be provided in addition to the working area.
- 5.5.16.7 A permanent sealed access track with stormwater control shall at no point be steeper than 1-in-5 (11.3 degrees, 20% grade).
- 5.5.16.8 Unsealed or undrained tracks shall at no point be steeper than 1-in-7 (8.1 degrees, 14.4% grade).
- 5.5.16.9 Where the piped system is less than 300mm diameter the Engineering Manager may approve an access suitable for pedestrian only. Under no circumstances though, will approval be given for an access steeper than 1-in-2. An easement may be required to protect the access-way. (See also the Legal section on legal easements).
- 5.5.16.10 Drawings of the proposed access shall be submitted to Council for approval prior to commencing construction of the access.
- 5.5.16.11 Where located on private land, the access shall be covered by an easement or right-of-way in favour of Council from legal road reserve to the location of the structure.
- 5.5.16.12 To encourage the best use of these reserves they shall be linked wherever possible with other reserves and other public open spaces, to accommodate off road pedestrian and cycle access.
- 5.5.16.13 Access points for public use and maintenance shall be provided at regular intervals along the system together with footpath and pedestrian bridges, as may be defined in the resource consent.

- 5.5.16.14 The design and construction of any stormwater management practice shall take into consideration the future ownership, access and maintenance requirements and shall ensure that maintenance can be carried out with little or no disturbance to the surroundings or neighbouring properties.
- 5.5.16.15 Surface cut off drains may be required parallel and adjacent to the uphill boundaries of upper sections to protect them from surface water runoff. When required these shall be located within the lots that are to be protected and secured with easements in favour of the lots being protected. A consent notice shall be registered on the section outlining that the property owner is responsible for maintaining the cut-off drain.

5.6 Construction and Installation

Mandatory Matters

The following requirements are mandatory in respect of the installation of stormwater management systems.

5.6.1 General

- 5.6.1.1 The selection of materials and construction methods must ensure durability, robustness, and ease of maintenance.

5.6.2 Health and safety

- 5.6.2.1 The health and safety risks associated with a stormwater system and its construction shall be considered and include, but not be limited to, dangers of entrapment, engulfment and asphyxiation.
- 5.6.2.2 Any confined spaces within the public stormwater network shall only be accessed by an authorised and trained person. Contractors working for Council in or around the stormwater network shall submit for review a safe work methodology with supporting training evidence and an applied risk assessment relating to the intended work.
- 5.6.2.3 Prior to commencing any physical works on the public stormwater network involving physical access, all contractors shall meet the council's minimum health and safety requirements, have a current, Site-Specific Safety Plan (or safe work methodology) for the particular project, and have gained Engineering Approval if required. Where the Council is aware of an existing site-specific hazard, they will notify the Contractor of it.

5.6.3 Trenching

- 5.6.3.1 The minimum trench width shall be 300mm wider than the external diameter of the collar of the pipe being laid.
- 5.6.3.2 The trench shall be of sufficient width to permit with freedom the installation of all trench support and to allow the laying and jointing of pipes and placing of bedding and pipe surround materials. See SD 801 and 802.
- 5.6.3.3 No construction or work upon the excavation bottom shall commence until the natural bottom of the excavation has been inspected for stability and accepted by a suitably experienced person.

- 5.6.3.4 A plate compactor shall be run over the trench floor to bind the surface and identify any obvious weak spots.
- 5.6.3.5 The contractor shall provide trench support to comply with the requirements of WorkSafe New Zealand. The contractor shall ensure that the sides of the trench are sufficiently supported so that cracking of the surrounding ground does not occur.
- 5.6.3.6 Excavations shall be kept free of water during construction with sediment laden water treated.
- 5.6.3.7 In no circumstances shall stormwater or ground water be allowed to drain into any existing wastewater drain, and pipe ends shall be plugged to prevent such ingress.
- 5.6.3.8 Where the only reasonable solution is for a trench to cross an existing watercourse, drain, or gully, etc., then, the contractor shall strip all vegetation and organic material from the sides and bottom before placing foundations or backfill. Vegetation reinstatement shall be in accordance with an approved landscaping plan.
- 5.6.3.9 Silt traps shall be installed and maintained to prevent debris and suspended matter from entering waterbodies, groundwater, or the stormwater reticulation.
- 5.6.3.10 Should deposits in existing stormwater drains or the pipes already laid occur as a result of the operations of the Developer or the contractor such deposits shall be cleared forthwith at the Developer's or the contractor's cost as the case may be.
- 5.6.3.11 The contractor or Developer shall cause as little damage or interference to property or persons as possible in disposing of water from the works, and shall be responsible for any damage or interference, which may be caused. This shall include any damage to the structure of any road.
- 5.6.3.12 Where the bottom of an excavation is unable to provide a firm foundation with minimum bearing capacity of 50kPa (eg., clay soils that can easily be penetrated 40mm with a thumb or in sand or gravel that makes a footprint more than 10mm deep) at the required level without abrupt irregularities, engineering advice should be sought on how to provide a satisfactory foundation (see AS/NZS 2032, clause 5.3.6).
- 5.6.3.13 Where required, additional granular bedding material as specified in AS/NZS3725 for concrete pipes, or AS/NZS2566.2:2002 for PVC and other flexible pipe systems should be placed, compacted and re-inspected.
- 5.6.3.14 Where trench support extends below the invert of the pipeline or structure, special precautions may be required, including leaving part of the support in place, to ensure the foundation of the pipe or structure is not weakened.

5.6.4 Bedding of pipes

- 5.6.4.1 Drainage Metal Bedding shall be in accordance with SD 614 – SD 615. (For concrete pipes, "Type H2" bedding in accordance with AS/NZS 3725:2007 shall be used.) Note: Includes bedding, haunch support and side support material as defined by NZS2566.2 and AS/NZS3725.
- 5.6.4.2 The bedding material shall be:
- a) In a sand environment – sand.
 - b) For PVC and flexible pipes – NZTA M4 AP20 or as per AS/NZS2566, Appendix G.
 - c) For concrete pipes – NZTA M4 AP20 or as per AS/NZS3725, Table 6.

- d) Specific design can be submitted for appraisal by Council on a case by case basis.
- e) For PE pipes refer to the manufacturers bedding specifications.

- 5.6.4.3 Bedding shall be placed and raked-in so as to provide support for the pipe uniformly along the whole length of the barrel with chases provided for sockets, couplings and other appurtenances.
- 5.6.4.4 For PVC and flexible pipes, the bedding shall not be compacted, and the centre of the bedding shall not be walked on either during or after placement. For concrete pipes only, the centre strip of the bedding shall not be compacted (see SD614 – SD615).
- 5.6.4.5 The pipes shall be laid and brought to true alignment and level before installing the drainage metal haunching, side support and covering the pipes.
- 5.6.4.6 The drainage metal haunching and side support shall be placed uniformly along and around the whole length of the pipe barrel, couplings and other appurtenances in a manner to ensure uniform density of side support (including haunch support) and overlay with no distortion, dislodgement or damage to the pipeline.
- 5.6.4.7 Following placement, the embedment material shall be compacted in layers to uniformly support the pipe. When choosing compaction equipment, the number of passes and the thickness of layer to be compacted, account shall be taken of the material to be compacted and the pipe to be installed.
- 5.6.4.8 Compaction equipment or methods that produce horizontal or vertical earth pressures that may cause damage to, or excessive distortion of, the pipe shall not be employed.
- 5.6.4.9 Drainage metal haunching and side support shall be compacted to the manufacturer's requirements. For public infrastructure, a minimum Clegg Impact Value of 25 shall be achieved at any point on any haunching constructed of AP20.

5.6.5 Pipe installation

- 5.6.5.1 To help with future identification the end caps and inside of the end of all new stormwater laterals must be painted with green acrylic paint and marked with a 75mm x 25mm ground treated marker stake suitably identified and partly painted green. (Note: wastewater laterals are to be marked red.)
- 5.6.5.2 A laser shall be used by the contractor for fixing line and grade, for setting the pipes to line and level, and for jointing on all major pipe laying work where possible.
- 5.6.5.3 The maximum deviation in level of pipe invert when laid shall be 5mm from design level.
- 5.6.5.4 The maximum horizontal deviation from a straight line shall be 10mm.
- 5.6.5.5 Pipes shall not be laid on bricks, blocks and wedges or other temporary or permanent supports except when concrete surround is to be placed.
- 5.6.5.6 Joints shall be flexible and watertight.
- 5.6.5.7 Pipes shall be kept clear of dirt or debris, and any pipes that contain such matter shall be required to be cleaned out. Internal pipe walls shall be kept clean and free of all dirt, rubbish and water. Spigots, sockets, rubber rings, etc., shall be thoroughly cleaned before jointing.

5.6.6 Manholes and access points

- 5.6.6.1 Manholes shall be constructed in accordance with SD511 and SD512.
- 5.6.6.2 All concrete manholes shall be made water tight by effective sealing of manhole section joints with mastic sealant and around pipe entries, where applicable, using epoxy mortar inside and out.
- 5.6.6.3 Connections to the manhole liner must be positioned so that the opening formed in the liner is no closer than 300mm to the riser joint.
- 5.6.6.4 The connection of PVC pipes to concrete structures, such as manholes and sumps, shall be with a PVC starter and finisher with a 'gritted' external surface.
- 5.6.6.5 All PVC pipes entering or leaving a manhole shall have one flexible joint within 200mm of the manhole and a second flexible joint within 1200mm of the manhole.
- 5.6.6.6 The channel through the manhole shall be formed from in-situ concrete properly formed to grade and radius sweeps. The channel shall be finished with a smooth, regular half circle invert with falls as specified in SD511 and SD512. Benching shall be steel float finished to give a regular smooth surface.
- 5.6.6.7 PE pipe connections to manholes will need specific design or the manhole may need to be PE also to get appropriate sealing of joints.

5.6.7 Concrete protection for pipes

- 5.6.7.1 At the discretion of the Engineering Manager, concrete pipes may require concrete surround under the following conditions:
- a) In areas subject to vehicle traffic where the cover of the pipe barrel is, or will be, less than that required for the class of pipe as specified by the pipe manufacturer.
 - b) In areas other than those covered above, where the cover over the barrel of the pipe is or will be less than 300mm, irrespective of the type or class of pipe.
- 5.6.7.2 Flotation of the pipe during placement of concrete surround shall be prevented. PVC pipes shall not be concrete surrounded.
- 5.6.7.3 Where cover over PVC pipes is less than the minimum stated in Table 5-13 including temporarily under construction traffic, a concrete protection slab shall be constructed.
- 5.6.7.4 Reduced cover for PE pipes will require specific design and approval from the Engineering Manager or delegate.

5.6.8 Groundwater and trench stops

- 5.6.8.1 Where there is a possibility of migration of fines between the native soil and the pipe surround soil, the drainage metals shall be protected by an approved geotextile filter fabric that overlaps by at least 300mm.
- 5.6.8.2 A specific design is needed where permeable bedding is used. Water-stops and trench drainage will be constructed to prevent unwanted movement of groundwater along the trench and pipe bedding, see SD613 (Chapter 6).

- 5.6.8.3 Manholes can be considered to be water-stops provided they are constructed appropriately. Where water stops are required, they should be provided at the intervals shown in Table 5-16.

Table 5-16 Water Stop Spacing

Pipe Grade	Maximum Spacing
1 in 15, 6.5% grade 3.8 degrees or steeper	12m
1 in 25, 4% grade, 2.5 degrees	15m
1 in 50, 2% grade, 1.15 degrees	30m
1 in 100, 1% grade, 0.57 degrees	60m

Note – Intermediate grades (and spacing) are determined by interpolation.

- 5.6.8.4 Trenchless technology may be used in specific circumstances where approved by the Engineering Manager.
- 5.6.8.5 Trenchless technology may be preferable for alignments passing through or under:
- Environmentally sensitive areas;
 - Built-up or congested areas to minimise disruption and reinstatement;
 - Major road crossings;
 - Significant vegetation;
 - Vehicle crossings and areas with high quality paving surface;
 - Where there is a large number of existing services;
 - Pipes used for trenchless installation shall have suitable mechanically restrained joints, specifically designed for trenchless application, which may include integral restraint, seal systems, or heat fusion welded joints.
- 5.6.8.6 For information on trenchless installation methods see Section 6.10 of the LDM.

5.6.9 Inspection and Testing

Mandatory Matters

Mandatory requirements for piped network inspections and testing are as follows.

5.6.10 General

- 5.6.10.1 Council requires inspection and testing of new pipes to help ensure that new infrastructure has been installed in accordance with this manual.

5.6.11 Closed-Circuit Television (CCTV) Inspection

- 5.6.11.1 All pipelines to be vested in Council ownership shall pass a closed-circuit television (CCTV) inspection, carried out at an appropriate time agreed by Council or at the completion of the works at the developer's costs.
- 5.6.11.2 A professional operator with proof of experience in operating such devices shall carry out the CCTV inspection using a pan and tilt camera, in accordance with the technical specifications of the NZ Pipe Inspection Manual (published by the New Zealand Water & Wastes Association).

- 5.6.11.3 The operator shall pan around every joint and check every lateral connection and defect.
- 5.6.11.4 The video footage in DVD format, and the accompanying CCTV log sheets for each stormwater length (as per the template in the NZ Pipe Inspection Manual), showing the features and condition of all inspected manhole lengths, shall be provided to Council accompanied by a report. Video footage supplied without log sheets and report will not be accepted.
- 5.6.11.5 All pipelines shall be free of debris and flushed within 24-hours prior to inspection. Inspections of non-cleaned pipelines are not acceptable.
- 5.6.11.6 A pipeline will fail its inspection if:
- The pipe is horizontally misaligned or deformed by more than 5% of the pipe diameter.
 - The pipe has visible dips or ponding of water.
 - The pipe has visible defects, such as open or displaced joints, defective or protruding laterals, cracked barrels or similar defects.

5.6.12 Pressure Testing

- 5.6.12.1 All plastic pipes and concrete pipes up to 300mm diameter shall generally be tested by the air testing procedure as outlined in the wastewater chapter refer Section 6.14 and/or as per NZS4404.

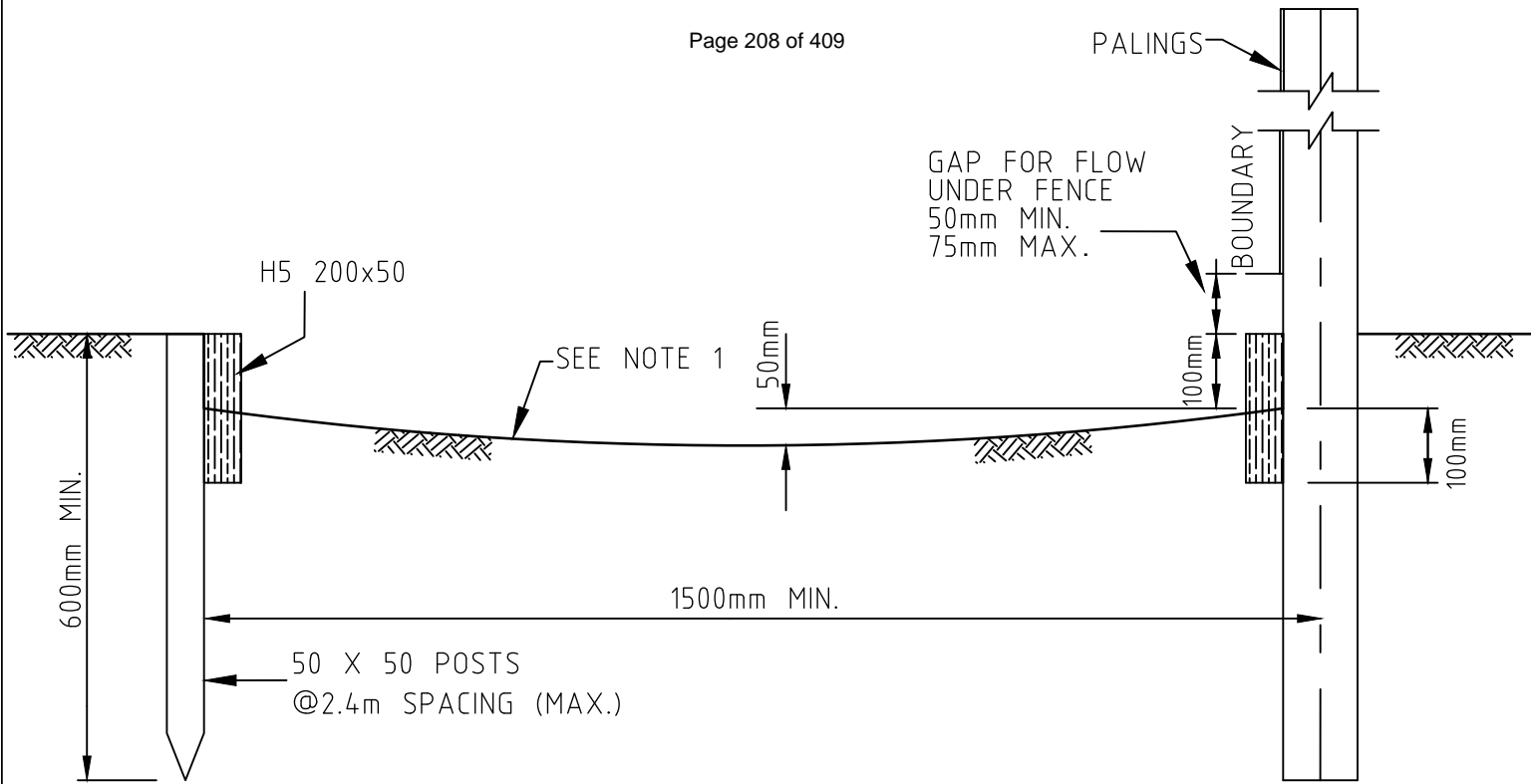

NOTES:

- 1. FOR 10 YEAR ARI FLOW VELOCITIES : <1.0m/s GRASS COVER IS SUFFICIENT
- : 1.0-1.5m/s REINFORCING MATTING IS REQUIRED
- : >1.5m/s ARMOURING IS REQUIRED

FLOW PATH DETAIL (NTS)

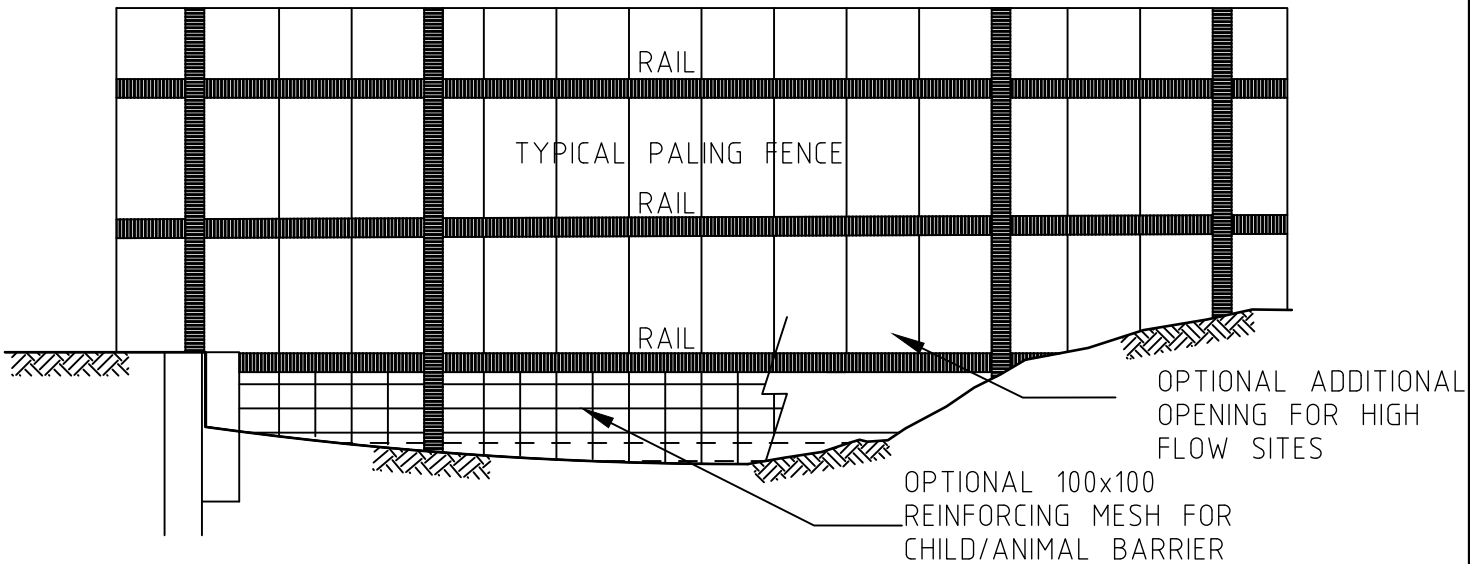

FENCE ACROSS SECONDARY FLOW PATH (NTS)

<p>NELSON CITY COUNCIL</p> <p><i>[Signature]</i></p> <p>GROUP MANAGER INFRASTRUCTURE, NELSON</p>	<p>SECONDARY FLOW PATH IN PRIVATE PROPERTY - GROUND / FENCE TREATMENT</p>		
<p>TASMAN DISTRICT COUNCIL</p> <p><i>[Signature]</i></p> <p>ENGINEERING SERVICES MANAGER, TASMAN</p>	<p>DATE</p> <p>01/07/19</p>	<p>NELSON - TASMAN LAND DEVELOPMENT MANUAL</p>	<p>501</p>

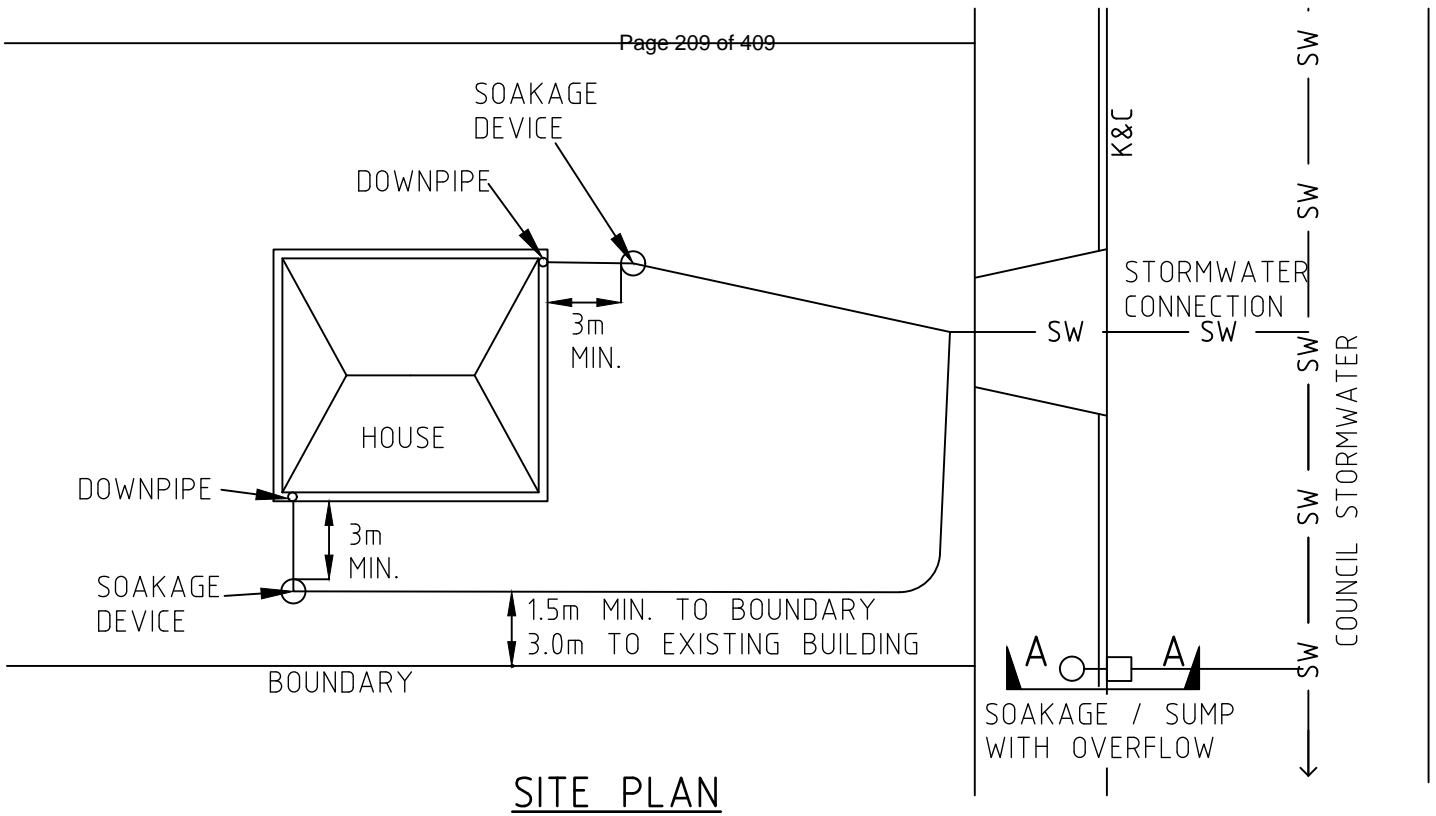

SITE PLAN

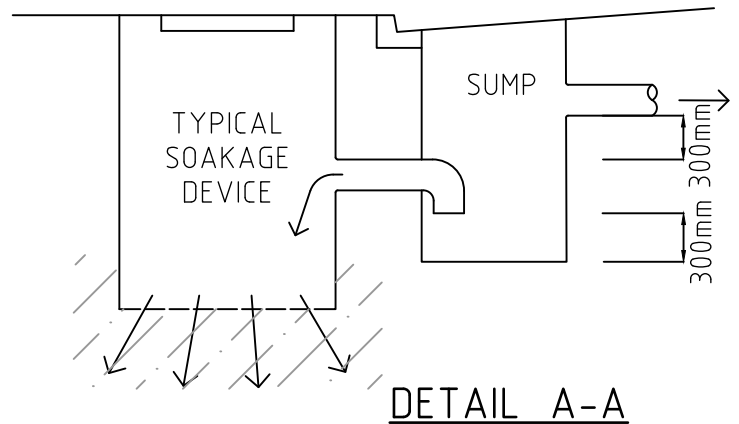

DETAIL A-A

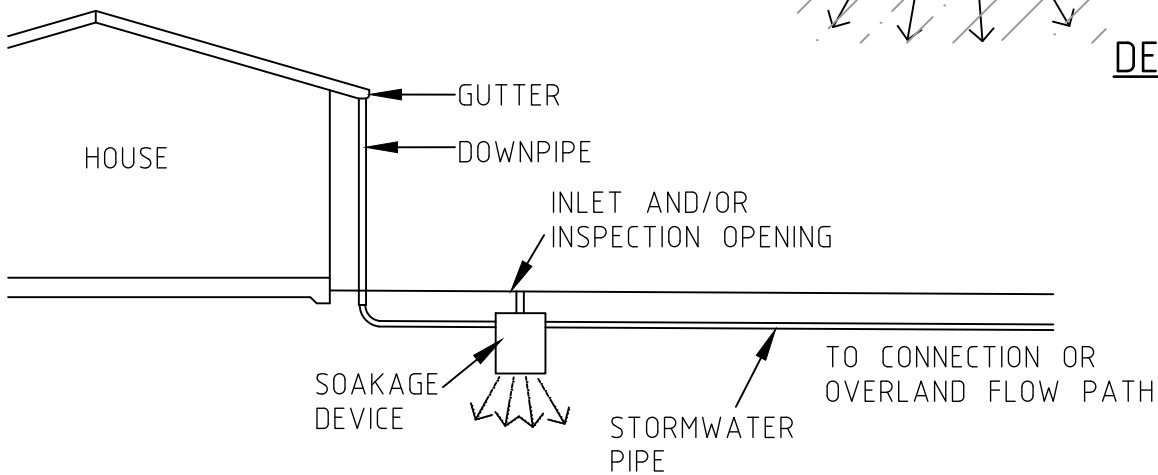

LONGITUDINAL SECTION

NELSON CITY COUNCIL

[Signature]
GROUP MANAGER INFRASTRUCTURE, NELSON

DESIGN FOR MINIMUM GROUNDWATER RECHARGE AND SEASONAL SOAKAGE

TASMAN DISTRICT COUNCIL

[Signature]
ENGINEERING SERVICES MANAGER, TASMAN

DATE
01/07/19

NELSON - TASMAN
LAND DEVELOPMENT MANUAL

502

CONCRETE ENCASED OUTFALL.
 1m LONG x DIA PLUS 200mm SQ. (TRIM ENDS TO MATCH BANK FACE.)

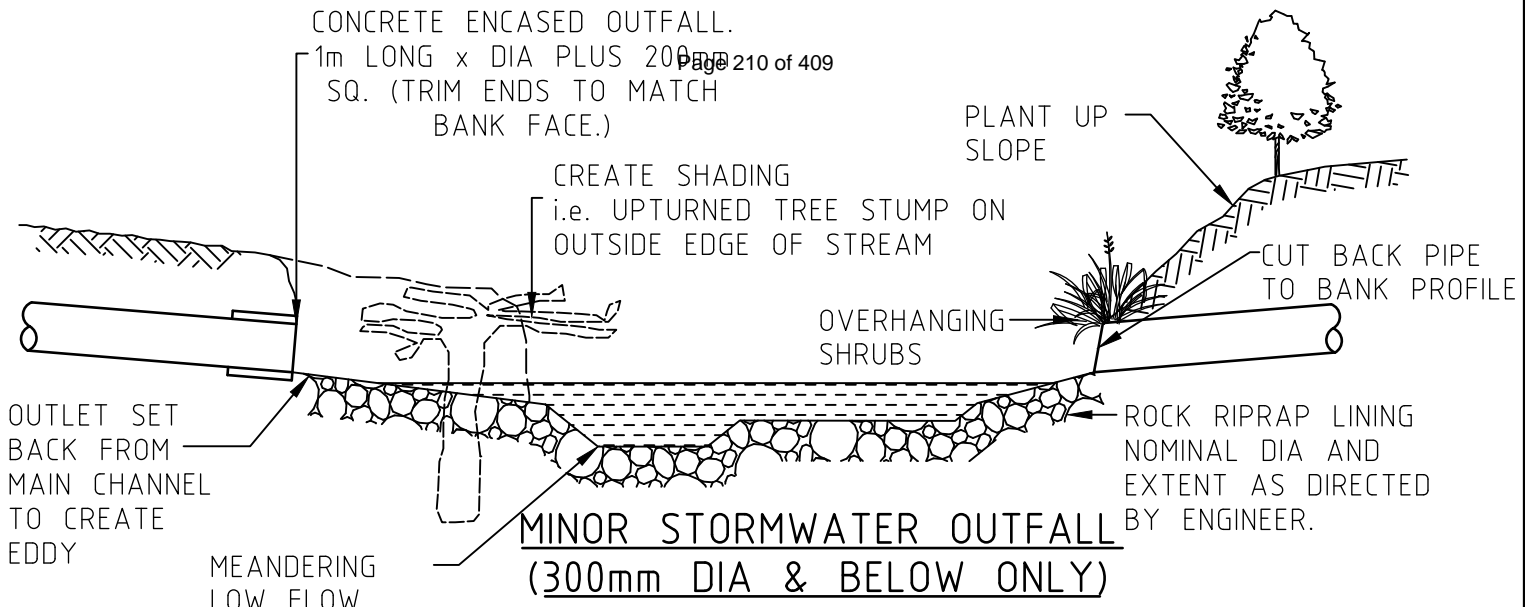

**MINOR STORMWATER OUTFALL
 (300mm DIA & BELOW ONLY)**

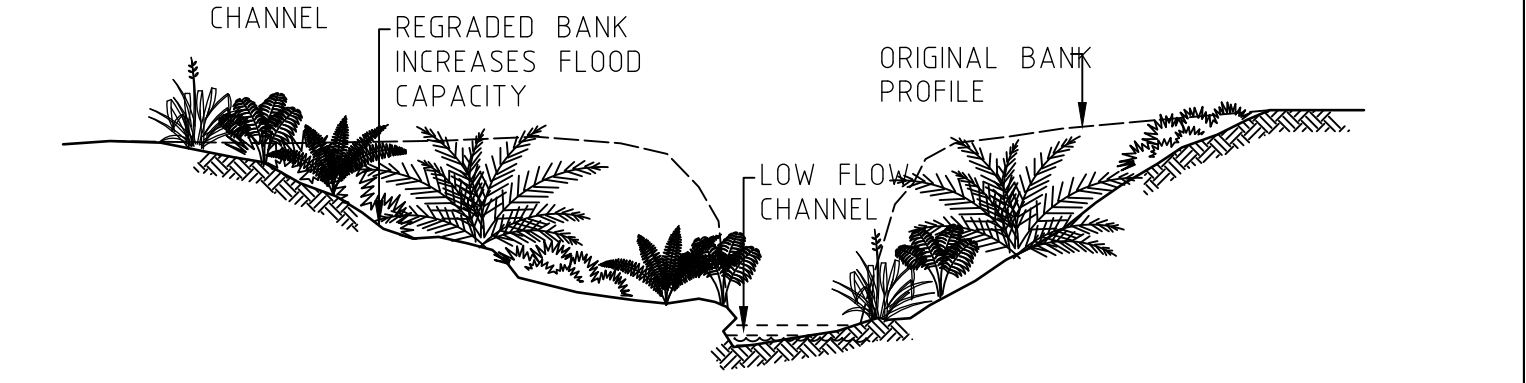

WATERWAY MEANDER

GENTLY SLOPING BANKS WILL BECOME INUNDATED DURING FLOOD FLOWS, ENABLING THE DISSIPATION OF FLOW ENERGY THAT WOULD OTHERWISE CONTRIBUTE TO CHANNEL DAMAGE. ENSURE FLOOD WATERWAY CAPACITY IS DESIGNED TO ACCOMMODATE MATURE VEGETATION.

NELSON CITY COUNCIL

 GROUP MANAGER INFRASTRUCTURE, NELSON

**OUTFALL DETAILS & DRAINAGE
 WATERWAY CONCEPTS**

TASMAN DISTRICT COUNCIL

 ENGINEERING SERVICES MANAGER, TASMAN

DATE
 01/07/19

NELSON - TASMAN
 LAND DEVELOPMENT MANUAL

503

PIPE END CUT AT 45° FOR PIPES LESS THAN 600mm ϕ . FOR PIPES GREATER THAN 600mm ϕ CUT END 45° TO MID PIPE GRIND BACK EXPOSED STEEL 20mm AND PLACE A BEAD OF EPOXY MORTAR ON CUT SURFACE

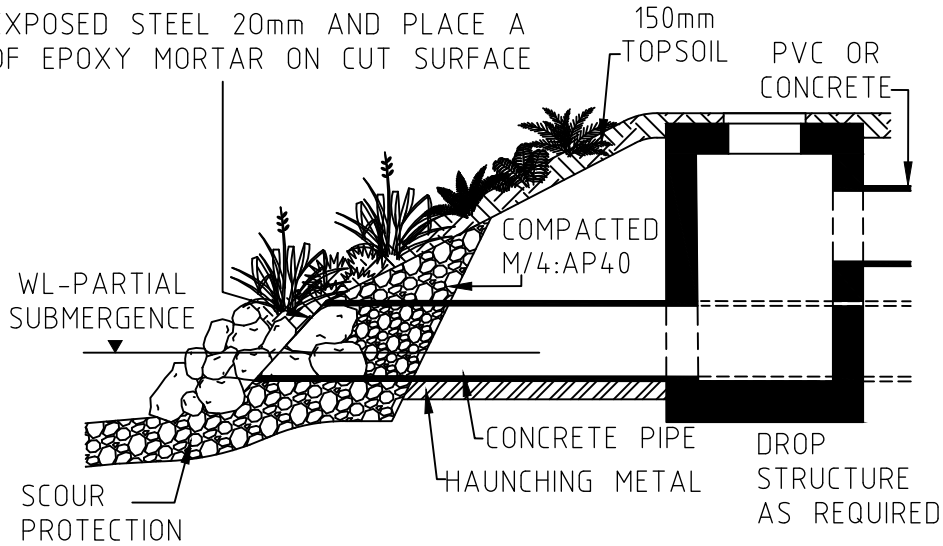

OUTFALL WITH DROP STRUCTURE

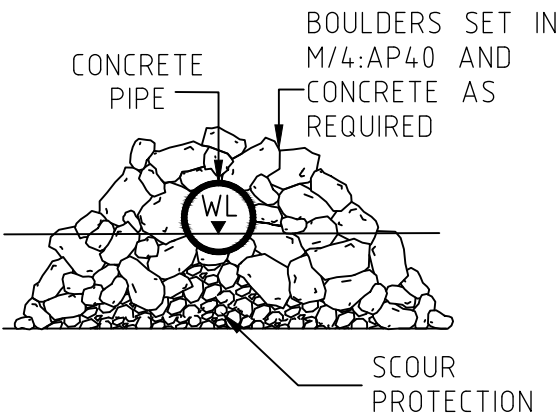

END VIEW



NOTES:

1. FISH PASSAGE TO BE PROVIDED FOR IN ALL OUTFALL DESIGNS WHERE REQUIRED

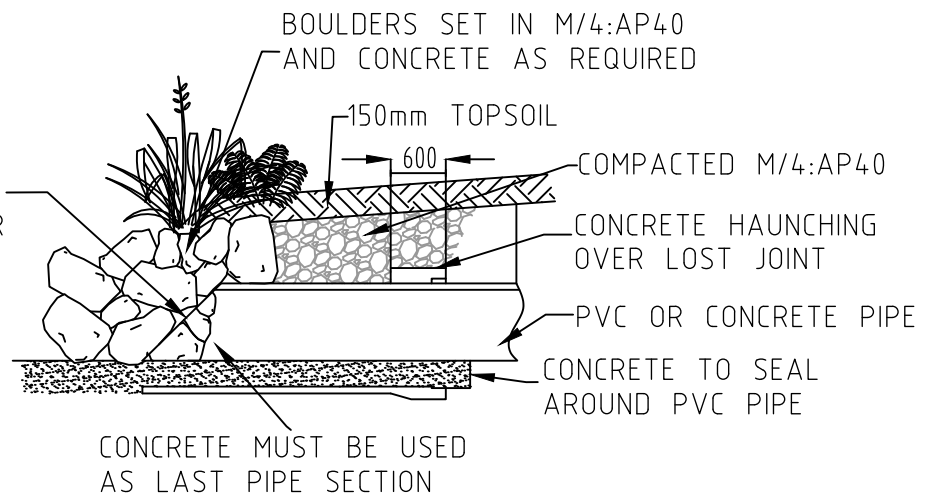
PIPE END CUT AT 45°. GRIND BACK EXPOSED STEEL 20mm AND PLACE BEAD OF EPOXY MORTAR ON CUT SURFACE

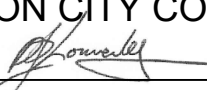

150-400mm DIAMETER OUTFALL

<p>NELSON CITY COUNCIL</p>  <p>GROUP MANAGER INFRASTRUCTURE, NELSON</p>	<p>150 - 400mmϕ OUTFALL DETAILS & DRAINAGE WATERWAY CONCEPTS</p>		
<p>TASMAN DISTRICT COUNCIL</p>  <p>ENGINEERING SERVICES MANAGER, TASMAN</p>	<p>DATE 01/07/19</p>	<p>NELSON - TASMAN LAND DEVELOPMENT MANUAL</p>	<p>504</p>

STANDARD GALVANISED
PIPE KERB ENTRY
ADAPTOR WITH LONG
DIMENSION VERTICAL.

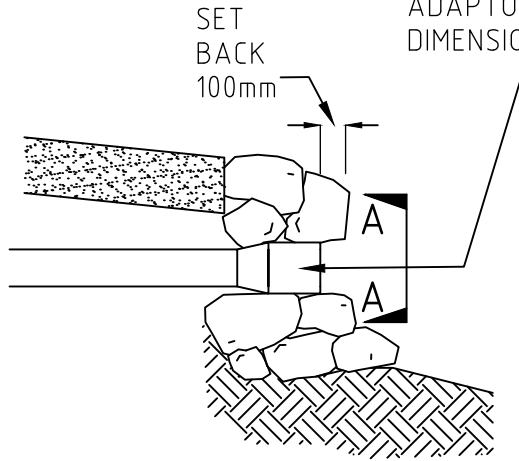

100mm OUTFALL THROUGH
ROCK RIP RAP

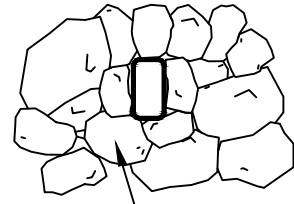

ROCK PLACED
AROUND ADAPTOR

DETAIL A-A

STANDARD GALVANISED
PIPE KERB ENTRY
ADAPTOR WITH LONG
DIMENSION VERTICAL TO
BANK SLOPE AND
ENCASED IN CONCRETE
27.5MPa (MIN 100mm)

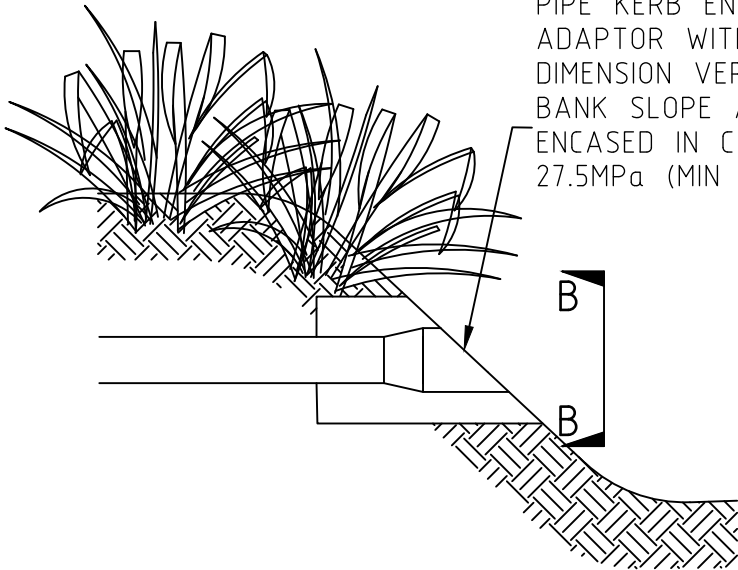

100mm OUTFALL THROUGH
VEGETATED BANK

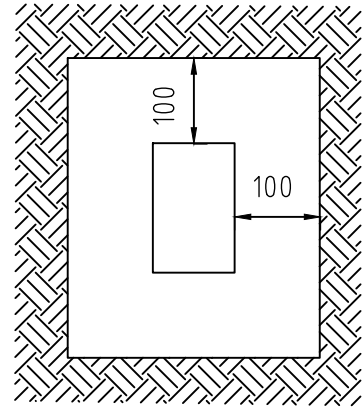

DETAIL B-B

NELSON CITY COUNCIL

GROUP MANAGER INFRASTRUCTURE, NELSON

100mmØ STORMWATER OUTLET
TO STREAMS - DETAILS

TASMAN DISTRICT COUNCIL

ENGINEERING SERVICES MANAGER, TASMAN

DATE

01/07/19

NELSON - TASMAN
LAND DEVELOPMENT MANUAL

505

NOTES

1. SEE DRAWING 507 FOR PIPE INLET SCHEDULE
2. SKEW AND/OR VERY STEEP APPROACH INLETS WILL REQUIRE DETAIL DESIGN BASED ON THIS STANDARD.
3. REINFORCING IS MINIMUM AND RETAINING WALL MUST BE DESIGNED FOR INDIVIDUAL CIRCUMSTANCES.
4. ALL REINFORCEMENT TO BE PLACED CENTRALLY IN WALLS AND FLOOR AND TO BE CONTINUOUS BETWEEN WALLS AND BETWEEN FLOOR AND WALLS.
5. AT LEAST 2 HORIZONTAL BARS TO BE PLACED OVER THE PIPE IN THE END WALL.
6. GRADE OF APRON TO BE NOT LESS THAN GRADE OF PIPE.
7. DIMENSIONS OF GRILL TO BE FULLY DETAILED FOR EACH CASE.
8. FULL HEADWALLS AND SIDEWALLS TO BE PROVIDED AS CASE REQUIRES IN ADDITION TO MINIMUM REQUIREMENT SHOWN.
9. THIS STANDARD SHOWS MINIMUM REQUIREMENTS : THE DETAILS OF CHANNEL APPROACH : DEPTH, STABILITY OF GROUND AND OTHER FACTORS IN EACH CASE MUST BE TAKEN INTO ACCOUNT IN THE DESIGN.
10. X SEE DRAWING 507 FOR ALTERNATIVE

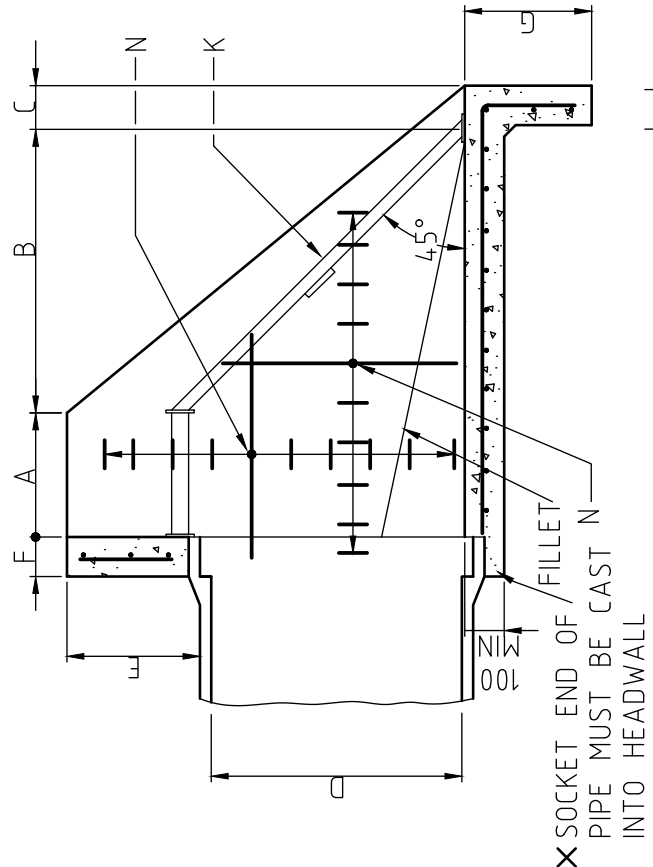

TYPICAL SECTION

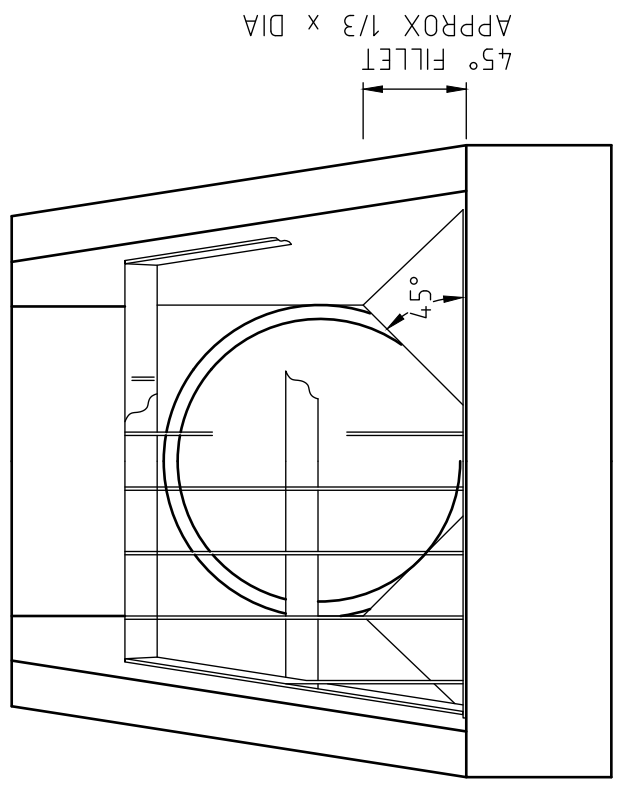

TYPICAL ELEVATION

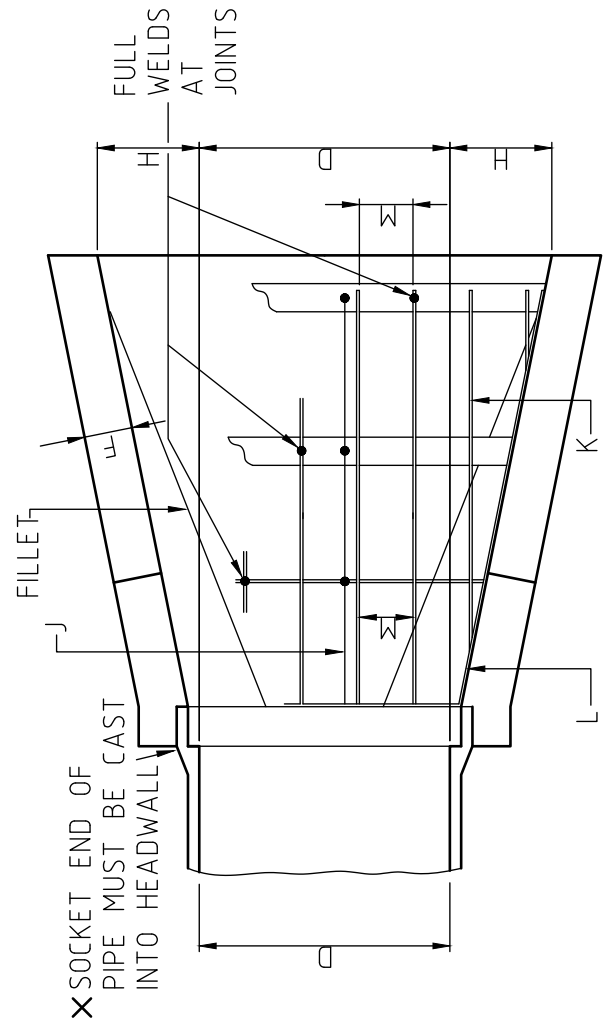

TYPICAL PLAN

NELSON CITY COUNCIL
 GROUP MANAGER INFRASTRUCTURE, NELSON

TYPICAL STORMWATER INTAKE STRUCTURE

TASMAN DISTRICT COUNCIL
 ENGINEERING SERVICES MANAGER, TASMAN

DATE
 01/07/19

NELSON - TASMAN
 LAND DEVELOPMENT MANUAL

506

PIPE INLET SCHEDULE

NOMINAL PIPE DIA	300	375	450	525	600	675	750	825	900	1075	1200	1350	1500	1575	1800
DETAIL A	300	300	300	300	400	400	400	400	400	600	600	700	700	800	800
B	500	500	600	700	800	800	900	1000	1100	1200	1400	1500	1700	1800	2000
C min	150	150	150	150	150	150	150	150	150	150	150	150	150	150	150
D	305	381	457	533	610	686	762	833	914	1067	1219	1372	1524	1600	1829
E min	300	300	450	450	450	450	450	450	450	450	450	450	450	450	450
F min	150	150	150	150	150	150	150	150	150	150	150	150	150	150	150
G min	400	400	400	400	500	500	500	500	500	600	600	600	600	600	600
H min	300	300	300	300	400	400	400	400	400	500	500	500	600	600	600
J	75x10 MS	75x10 MS	75x10 MS	100x10 MS	100x10 MS	100x10 MS	100x10 MS	100x10 MS	100x10 MS	100x10 MS	100x10 MS	100x10 MS	100x10 MS	100x10 MS	100x10 MS
K	25x10 MS	25x10 MS	25x10 MS	50x10 MS	50x10 MS	50x10 MS	50x10 MS	50x10 MS	50x10 MS	50x10 MS	50x10 MS	50x10 MS	50x10 MS	50x10 MS	50x10 MS
L	50x10 MS	50x10 MS	50x10 MS	75x10 MS	75x10 MS	75x10 MS	75x10 MS	75x10 MS	75x10 MS	75x10 MS	75x10 MS	75x10 MS	75x10 MS	75x10 MS	75x10 MS
M	200	200	200	200	200	200	200	200	200	200	200	200	200	200	200
N	6mm dia bars at 150 crs EW or equivalent mesh.												10mm dia Bars at 150 crs EW or equivalent mesh		
H.D BOLTS LINTEL	2x12 dia	2x12 dia	2x12 dia	2x12 dia	2x12 dia	2x12 dia	2x12 dia	2x12 dia	3x12 dia	3x12 dia	3x12 dia	4x12 dia	4x12 dia	4x12 dia	4x12 dia
H.D BOLTS APRON	3x12 dia	3x12 dia	3x12 dia	4x12 dia	4x12 dia	4x12 dia	4x12 dia	4x12 dia	5x12 dia	5x12 dia	5x12 dia	6x12 dia	6x12 dia	6x12 dia	6x12 dia

APPROVED PRECAST INLET STRUCTURES MAY BE USED

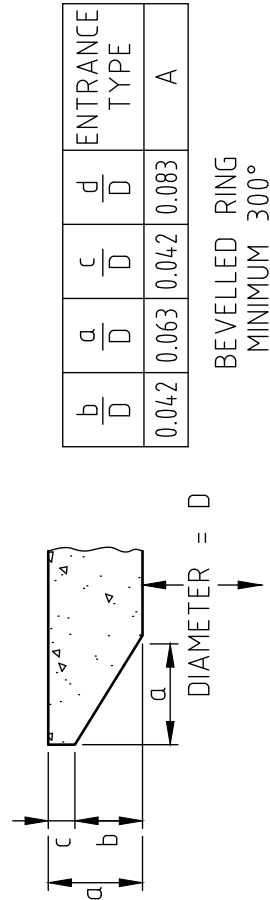

ALTERNATIVE TO SOCKET END OF PIPE

NELSON CITY COUNCIL

 GROUP MANAGER INFRASTRUCTURE, NELSON

PIPE INLET DEBRIS GRILL SCHEDULE

TASMAN DISTRICT COUNCIL

 ENGINEERING SERVICES MANAGER, TASMAN

DATE
01/07/19

NELSON - TASMAN
LAND DEVELOPMENT MANUAL

507

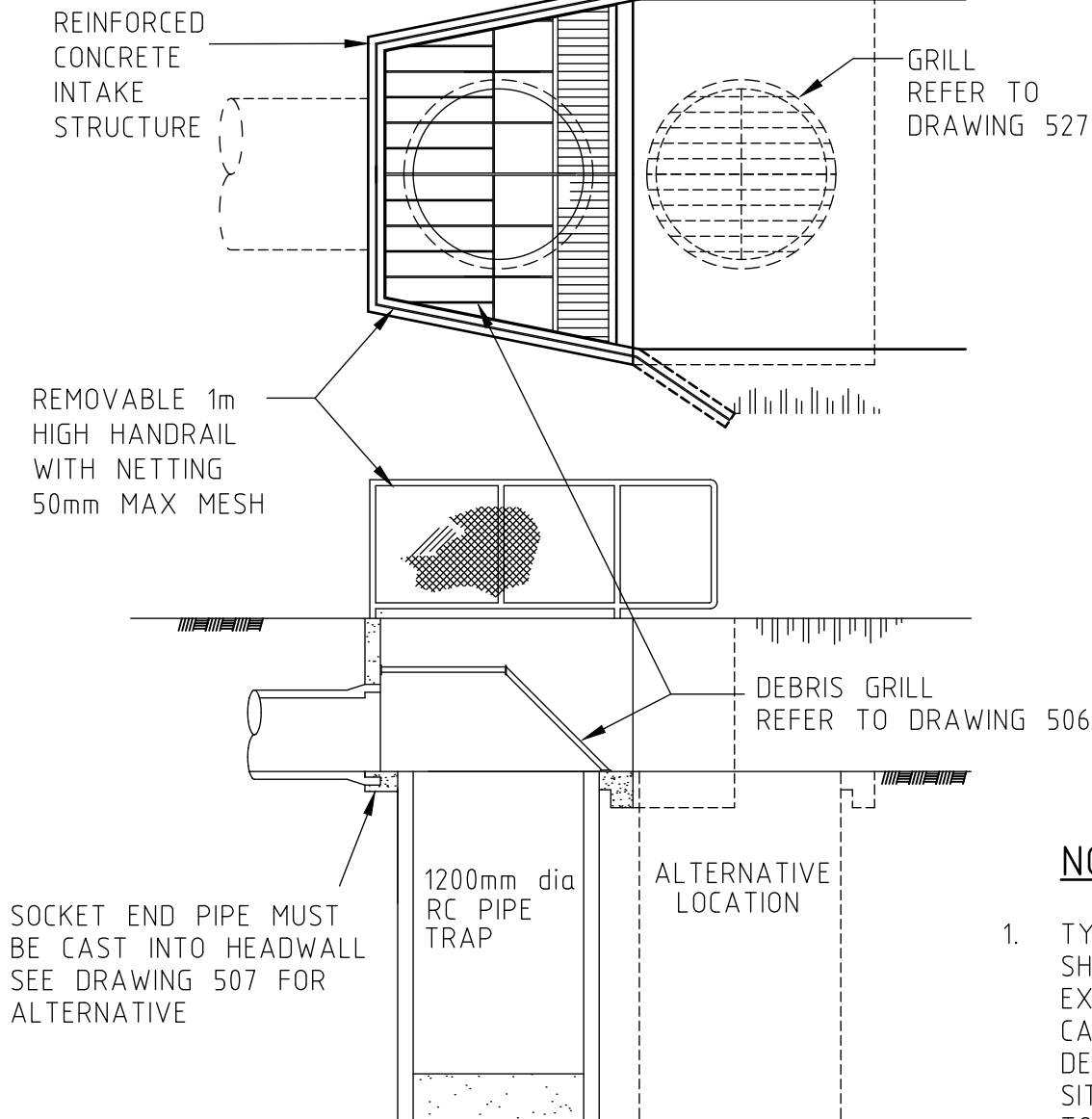

TYPE A: DEEP TRAP SUMP

NOTES

1. TYPES A,B,C AS SHOWN ARE GENERAL EXAMPLES - EACH CASE WILL REQUIRE DESIGN TO SUIT THE SITE WITH REGARD TO PEAK FLOWS AND ANTICIPATED DEBRIS: FINAL DETAILS SHALL BE SUBMITTED TO THE ENGINEER FOR APPROVAL

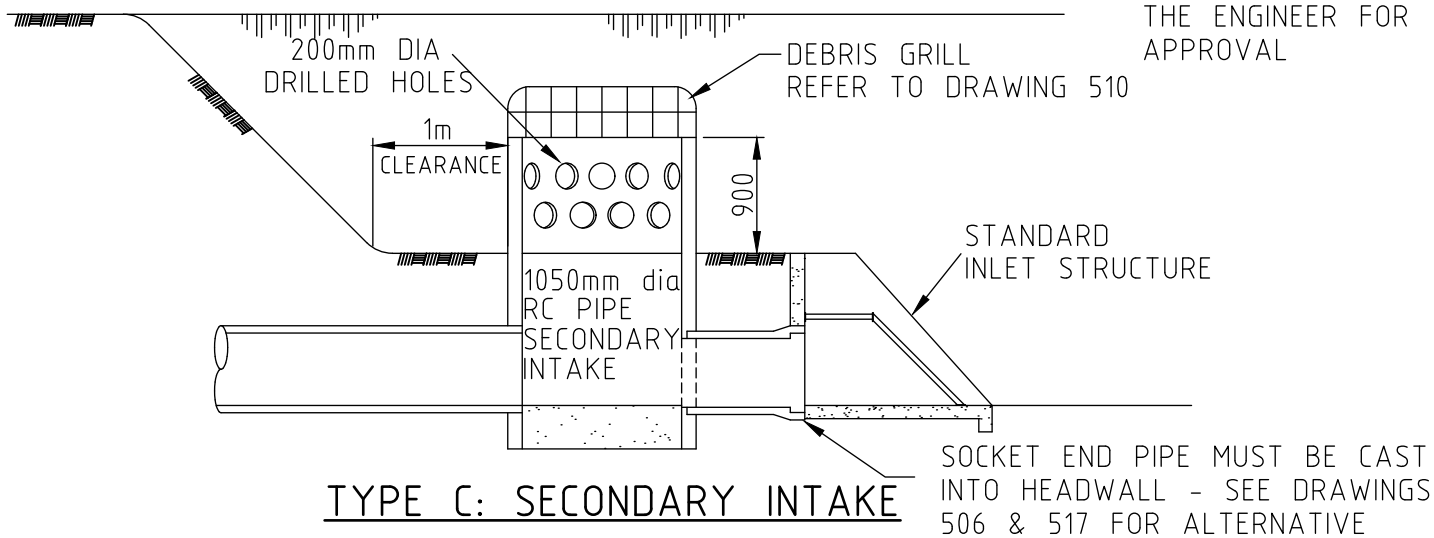

TYPE C: SECONDARY INTAKE

NELSON CITY COUNCIL

 GROUP MANAGER INFRASTRUCTURE, NELSON

STORMWATER INTAKE STRUCTURES WITH DEBRIS TRAPS (TYPES A & C)

TASMAN DISTRICT COUNCIL

 ENGINEERING SERVICES MANAGER, TASMAN

DATE
 01/07/19

NELSON - TASMAN
 LAND DEVELOPMENT MANUAL

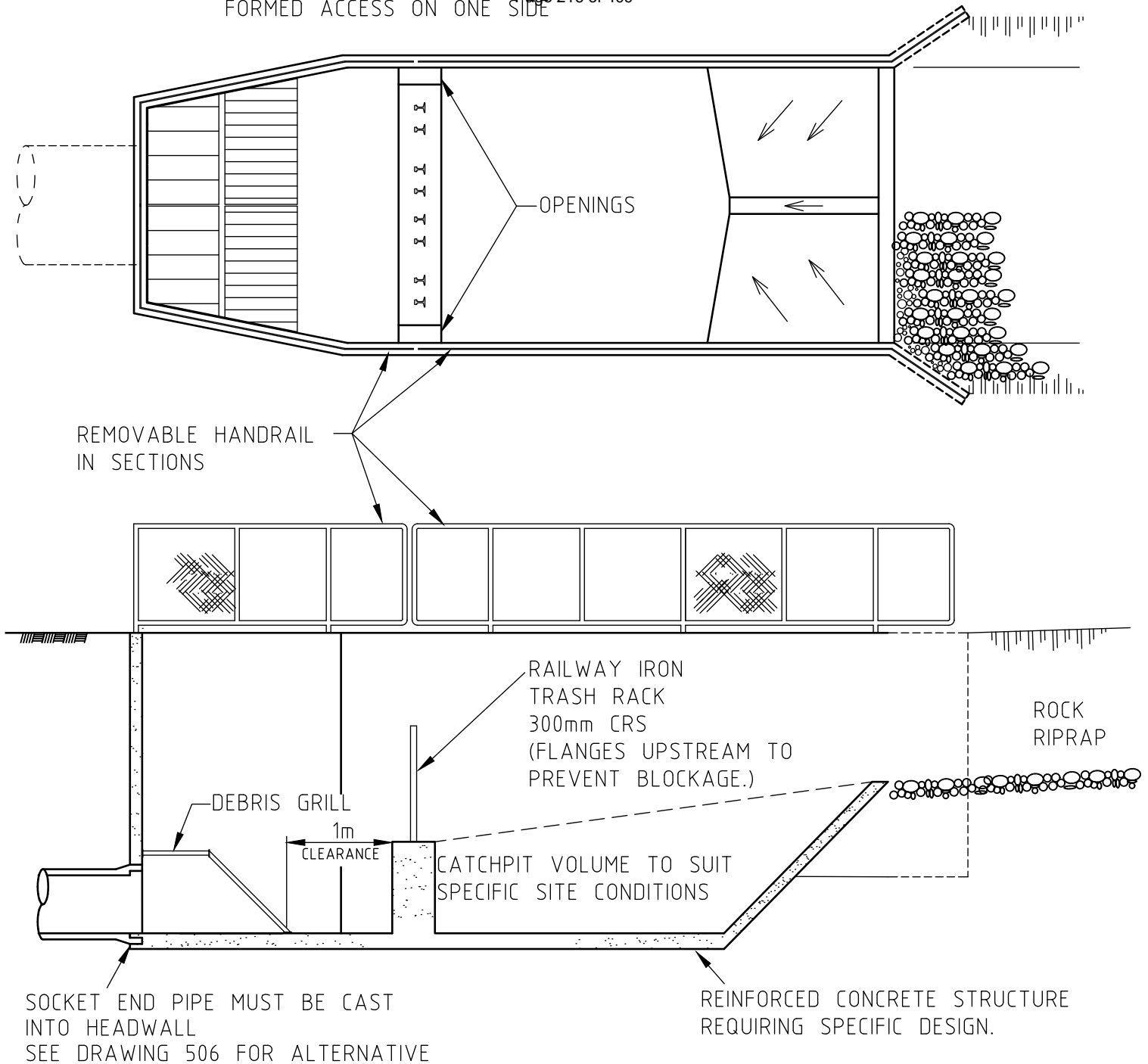

508



TYPE B: RAILWAY IRON TRASH RACK & CATCHPIT

NOTES

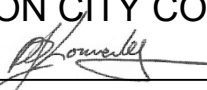
1. TYPES A,B,C AS SHOWN ARE GENERAL EXAMPLES - EACH CASE WILL REQUIRE DESIGN TO SUIT THE SITE WITH REGARD TO PEAK FLOWS AND ANTICIPATED DEBRIS: FINAL DETAILS SHALL BE SUBMITTED TO THE ENGINEER FOR APPROVAL
2. WHERE PROVISION FOR FISH PASSAGE IS REQUIRED BY COUNCIL, IT SHALL BE INCORPORATED INTO THE DESIGN

NELSON CITY COUNCIL  GROUP MANAGER INFRASTRUCTURE, NELSON		STORMWATER INTAKE STRUCTURES WITH DEBRIS TRAPS (TYPE B)	
TASMAN DISTRICT COUNCIL  ENGINEERING SERVICES MANAGER, TASMAN	DATE 01/07/19	NELSON - TASMAN LAND DEVELOPMENT MANUAL	509

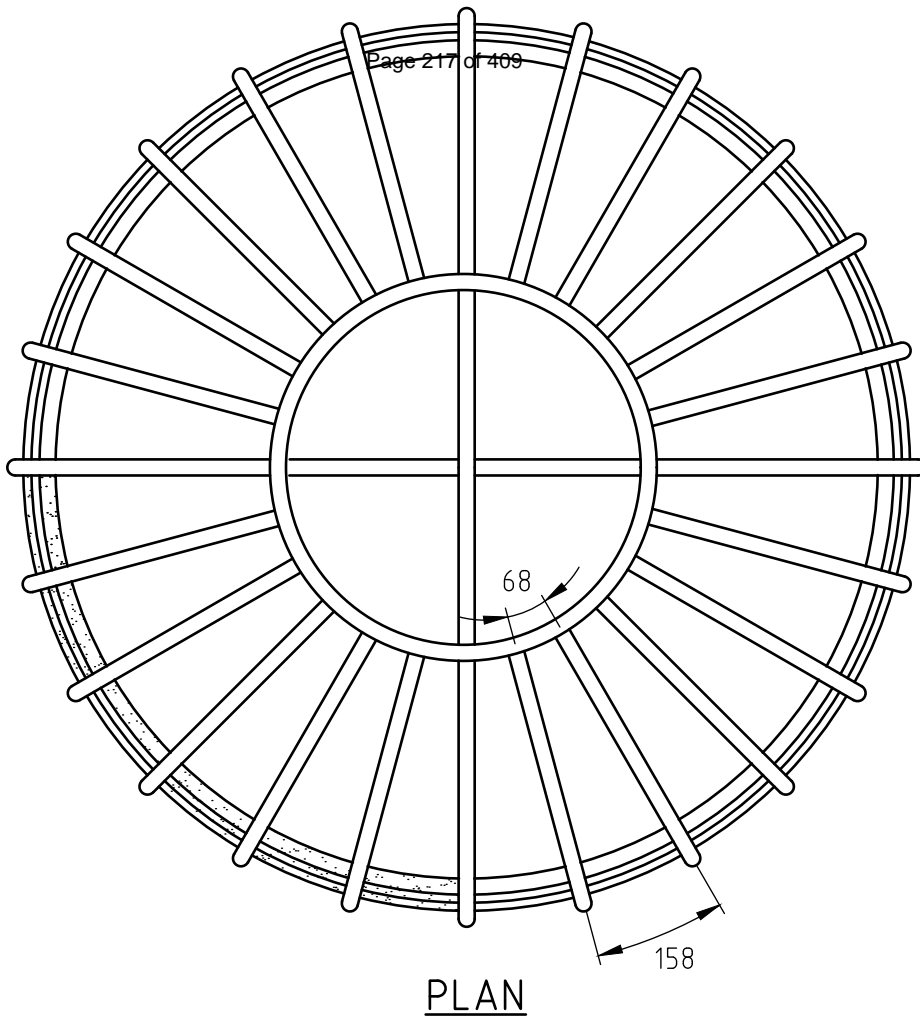

PLAN

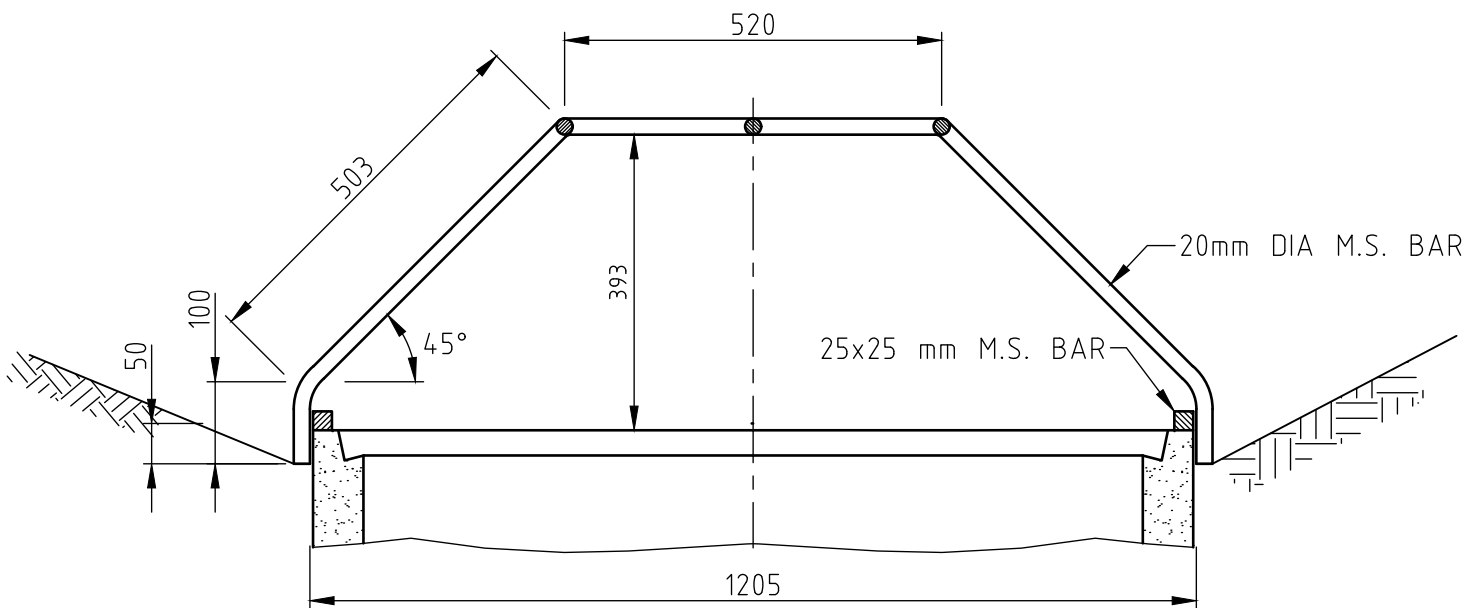

SECTION

NOTES

1. DETAILS SHOWING THE FIXING DOWN OF THE GRILL TO THE MANHOLE LINER SHALL BE DETERMINED AT THE TIME OF DESIGN.

NELSON CITY COUNCIL

[Signature]
GROUP MANAGER INFRASTRUCTURE, NELSON

SECONDARY INTAKE DEBRIS GRILL

TASMAN DISTRICT COUNCIL

[Signature]
ENGINEERING SERVICES MANAGER, TASMAN

DATE
01/07/19

NELSON - TASMAN
LAND DEVELOPMENT MANUAL

510

NOTES

1. FOR PIPES OVER 1050 DIA, MANHOLES ARE TO BE A SPECIFIC DESIGN.
2. TABLE OF DIMENSIONS

M.H(DIA)	L (MIN)	T (MIN)	D (MAX)
1500	500	200	1050
1350	400	200	750
1050	350	150	450
3. PRECAST CONCRETE MANHOLE RISERS SHALL COMPLY WITH THE REQUIREMENTS FOR CLASS 2 PRECAST CONCRETE PIPES TO AS/NZS 4058.
4. FOR MANHOLE FINISHING OFF DETAILS E.G. HAUNCHING, MAX. DEPTH OF LID, etc SEE DRAWINGS 601 & 602
5. SEE DRAWING 512 FOR SECTION VIEWS

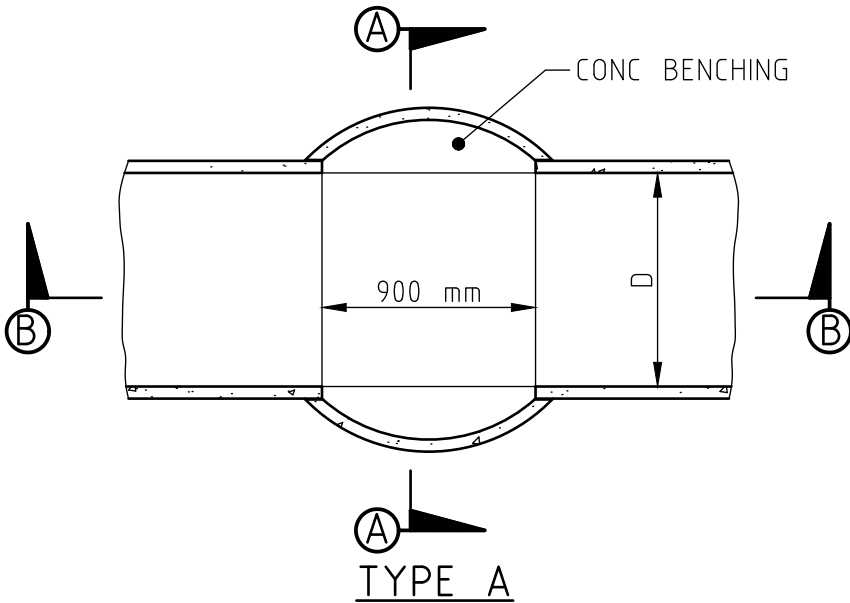

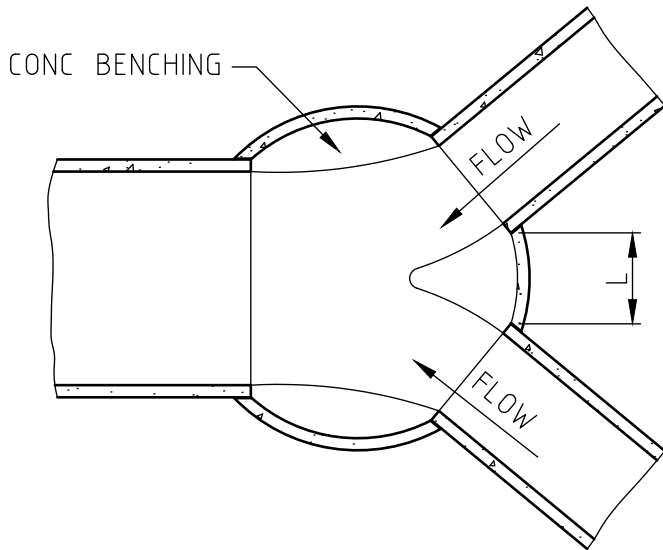

THROUGH CHANNEL
ONE PIPE DIA.

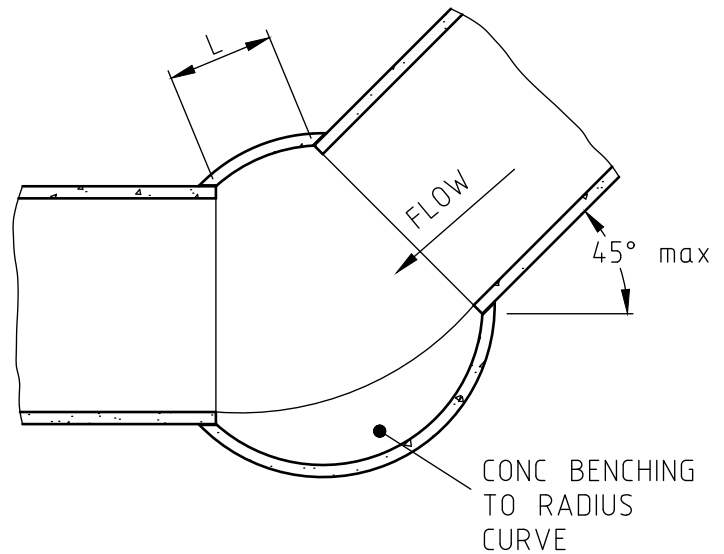

TYPE C
TYPICAL JUNCTION MANHOLE.



TYPE B
ANGLE CHANNEL
ONE PIPE DIA.

NELSON CITY COUNCIL  GROUP MANAGER INFRASTRUCTURE, NELSON	STANDARD STORMWATER MANHOLE (1 OF 2)		
TASMAN DISTRICT COUNCIL  ENGINEERING SERVICES MANAGER, TASMAN	DATE 01/07/19	NELSON - TASMAN LAND DEVELOPMENT MANUAL	511

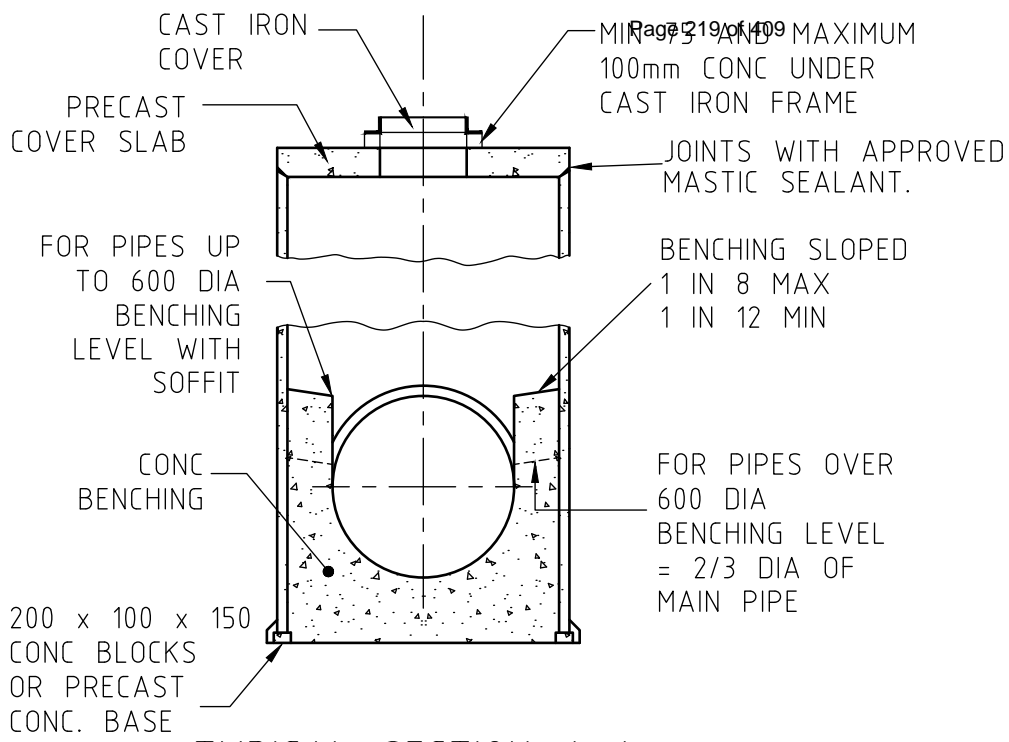

TYPICAL SECTION A-A
SEE DRAWING 511

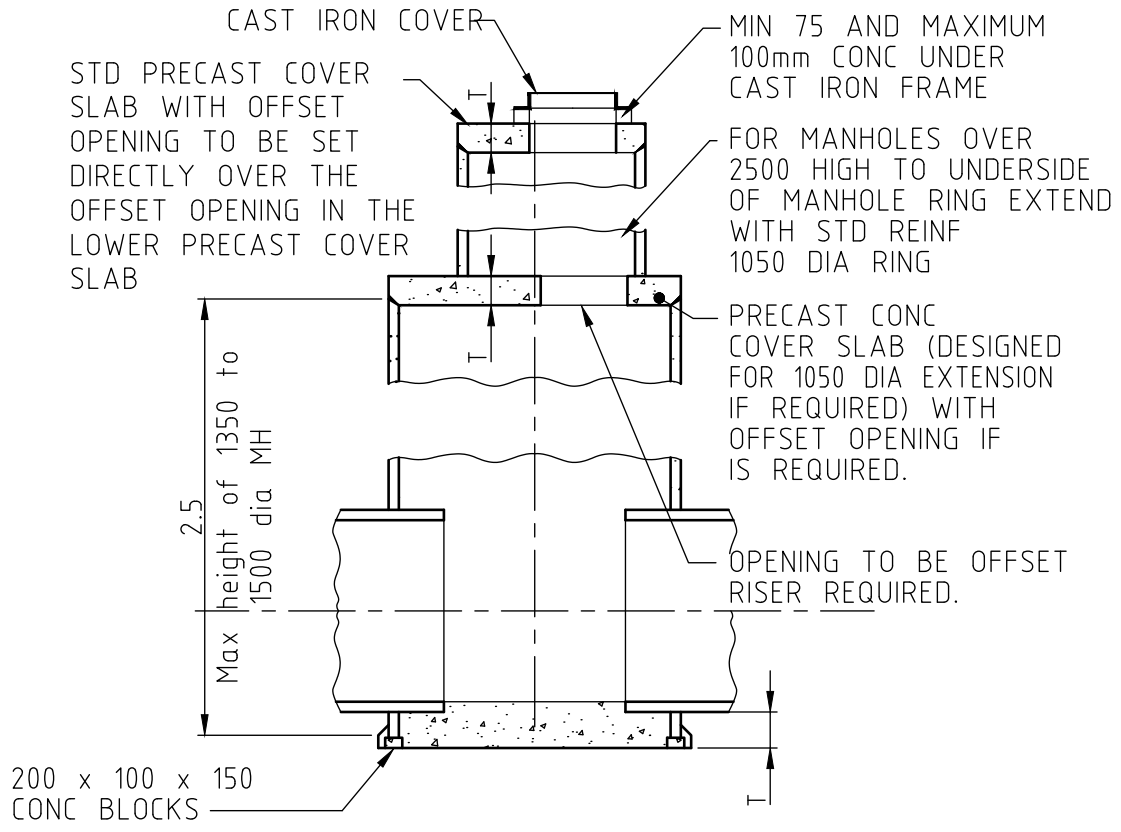

TYPICAL SECTION B-B
SEE DRAWING 511

<p>NELSON CITY COUNCIL</p> <p><i>[Signature]</i></p> <p>GROUP MANAGER INFRASTRUCTURE, NELSON</p>		<p>STANDARD STORMWATER MANHOLE - SECTIONS (2 OF 2)</p>	
<p>TASMAN DISTRICT COUNCIL</p> <p><i>[Signature]</i></p> <p>ENGINEERING SERVICES MANAGER, TASMAN</p>		<p>DATE</p> <p>01/07/19</p>	<p>NELSON - TASMAN LAND DEVELOPMENT MANUAL</p>
			<p>512</p>

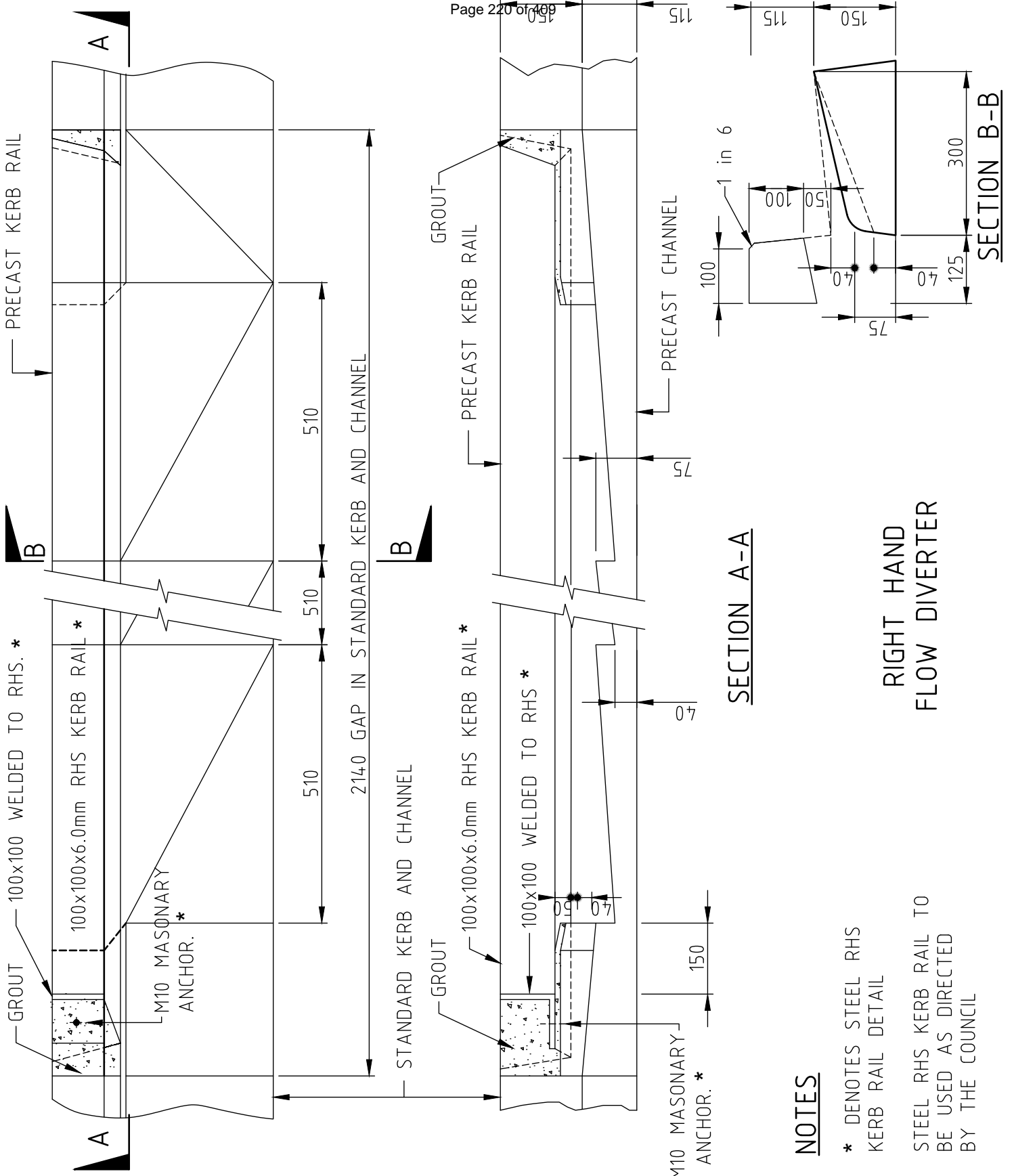

SECTION A-A

SECTION B-B

NOTES

1. * DENOTES STEEL RHS KERB RAIL DETAIL
2. STEEL RHS KERB RAIL TO BE USED AS DIRECTED BY THE COUNCIL

**RIGHT HAND
FLOW DIVERTER**

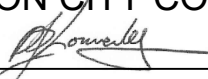
NELSON CITY COUNCIL

 GROUP MANAGER INFRASTRUCTURE, NELSON

**FLOW DIVERTER
(1 OF 2)**

TASMAN DISTRICT COUNCIL

 ENGINEERING SERVICES MANAGER, TASMAN

DATE
01/07/19

NELSON - TASMAN
LAND DEVELOPMENT MANUAL

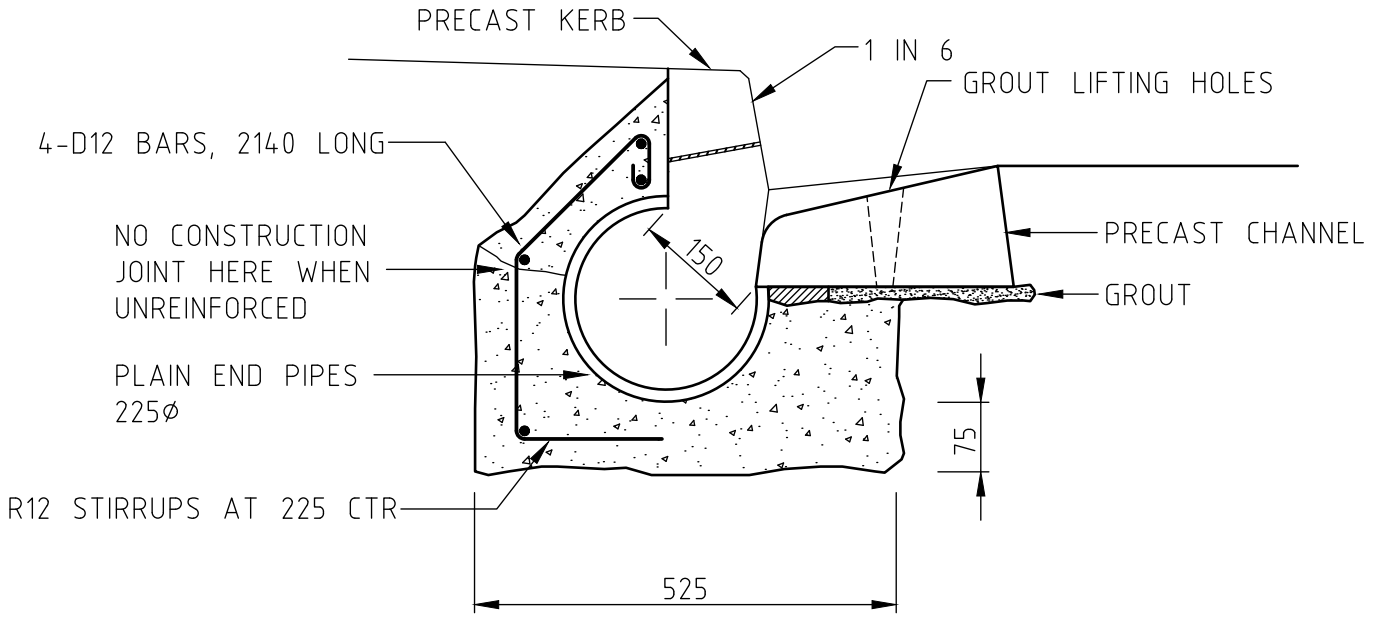

513

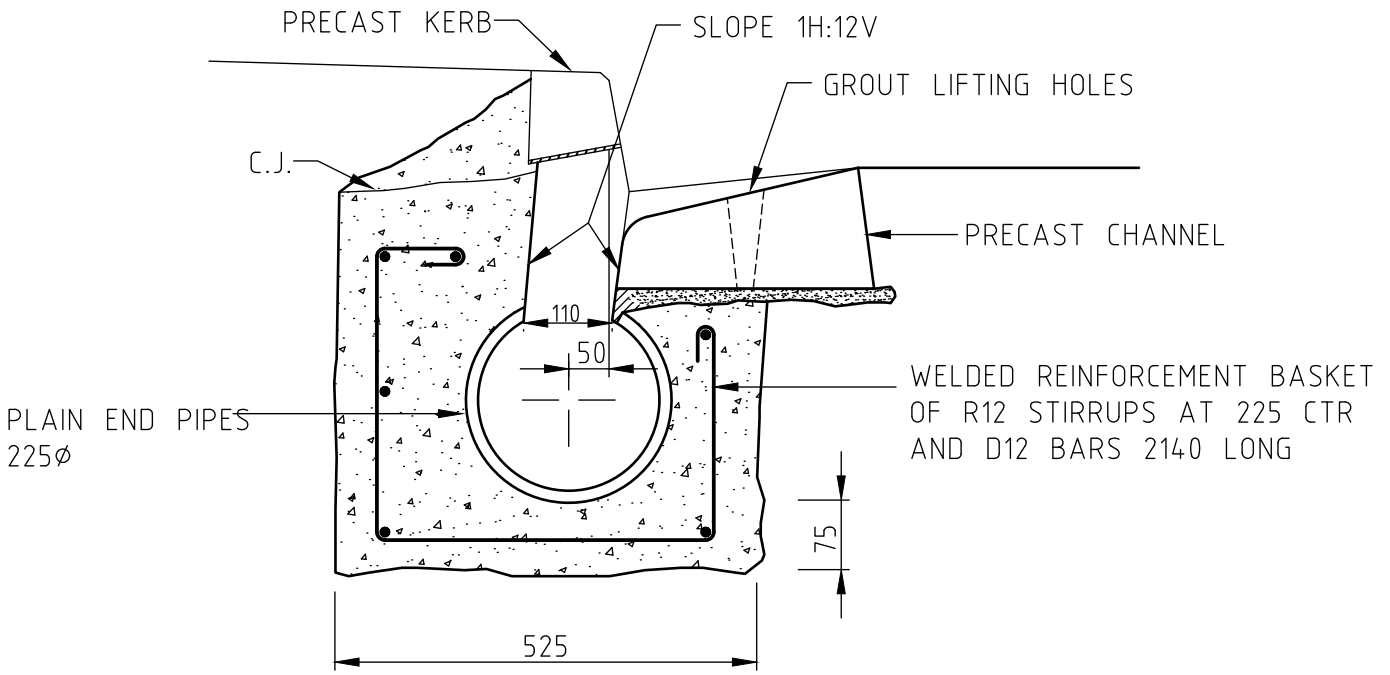

SPECIAL SHALLOW SECTION OF FLOW DIVERTER

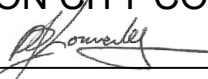

STANDARD INTAKE SECTION OF FLOW DIVERTER

<p>NELSON CITY COUNCIL</p>  <p>GROUP MANAGER INFRASTRUCTURE, NELSON</p>	<p>INTAKE SECTION ON FLOW DIVERTER (2 OF 2)</p>		
<p>TASMAN DISTRICT COUNCIL</p>  <p>ENGINEERING SERVICES MANAGER, TASMAN</p>	<p>DATE</p> <p>01/07/19</p>	<p>NELSON - TASMAN LAND DEVELOPMENT MANUAL</p>	<p>514</p>

CAST INSITU OR
PRECAST KERB ENTRY UNIT

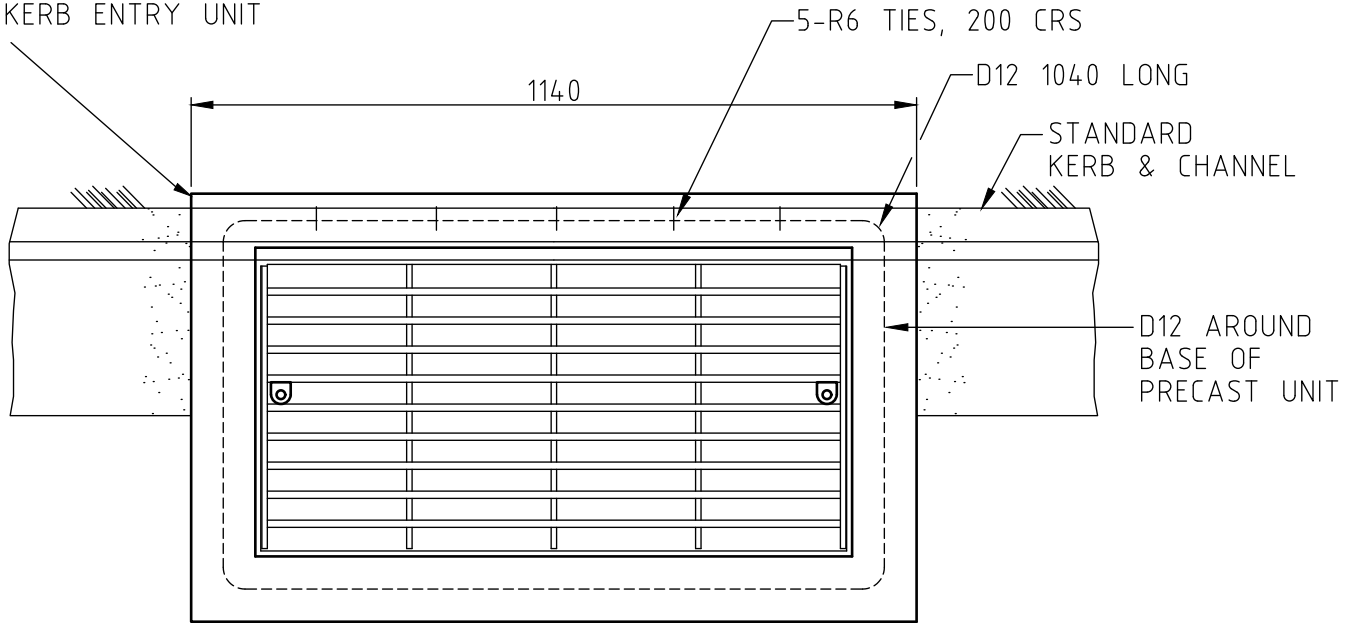

PLAN

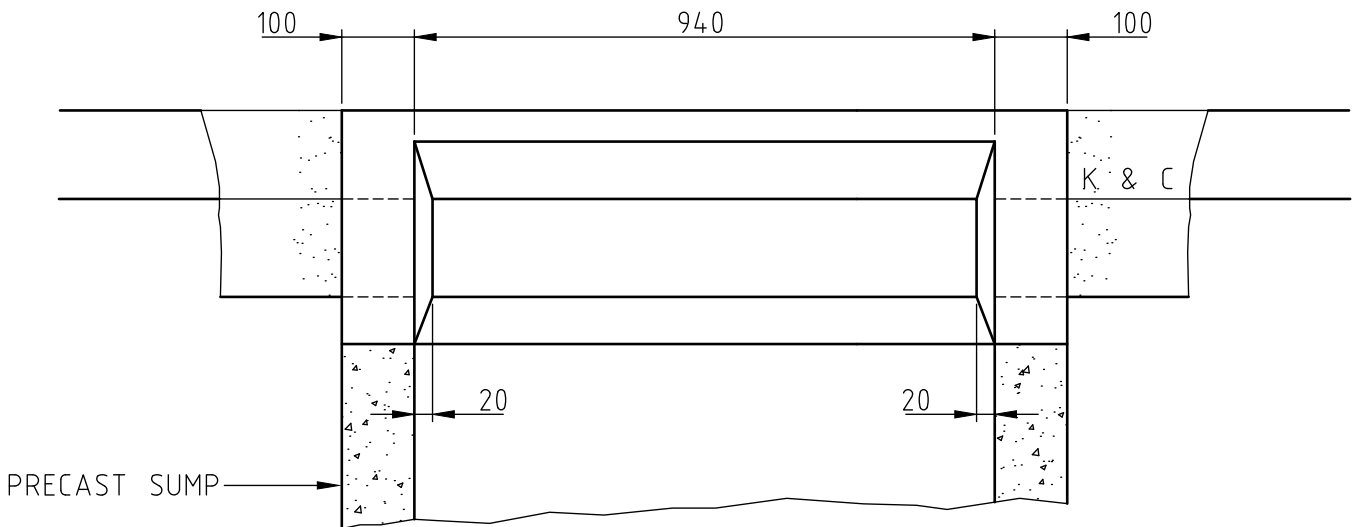

ELEVATION

GRATE AND FRAME NOT SHOWN

NOTES

1. SEE SHEET DRAWING 518 FOR DETAILS OF STD GRATING AND FRAME
2. INSITU CONCRETE TO BE 27.5 MPa AFTER 28 DAYS
3. NO REINFORCING REQUIRED FOR CAST INSITU BACK ENTRY UNIT
4. WHERE SUMP IS CONCRETED TO INTERCEPT K & C AT DISTINCT GRADE THE ENTRY UNIT SHALL BE INCLINED ON THE INSITU PAD EXTENDED OVER THE SUMP WALL WIDTH

NELSON CITY COUNCIL

[Signature]
GROUP MANAGER INFRASTRUCTURE, NELSON

**BACK ENTRY SUMP IN STANDARD KERB
& CHANNEL - PLAN & ELEVATION (1 OF 2)**

TASMAN DISTRICT COUNCIL

[Signature]
ENGINEERING SERVICES MANAGER, TASMAN

DATE
01/07/19

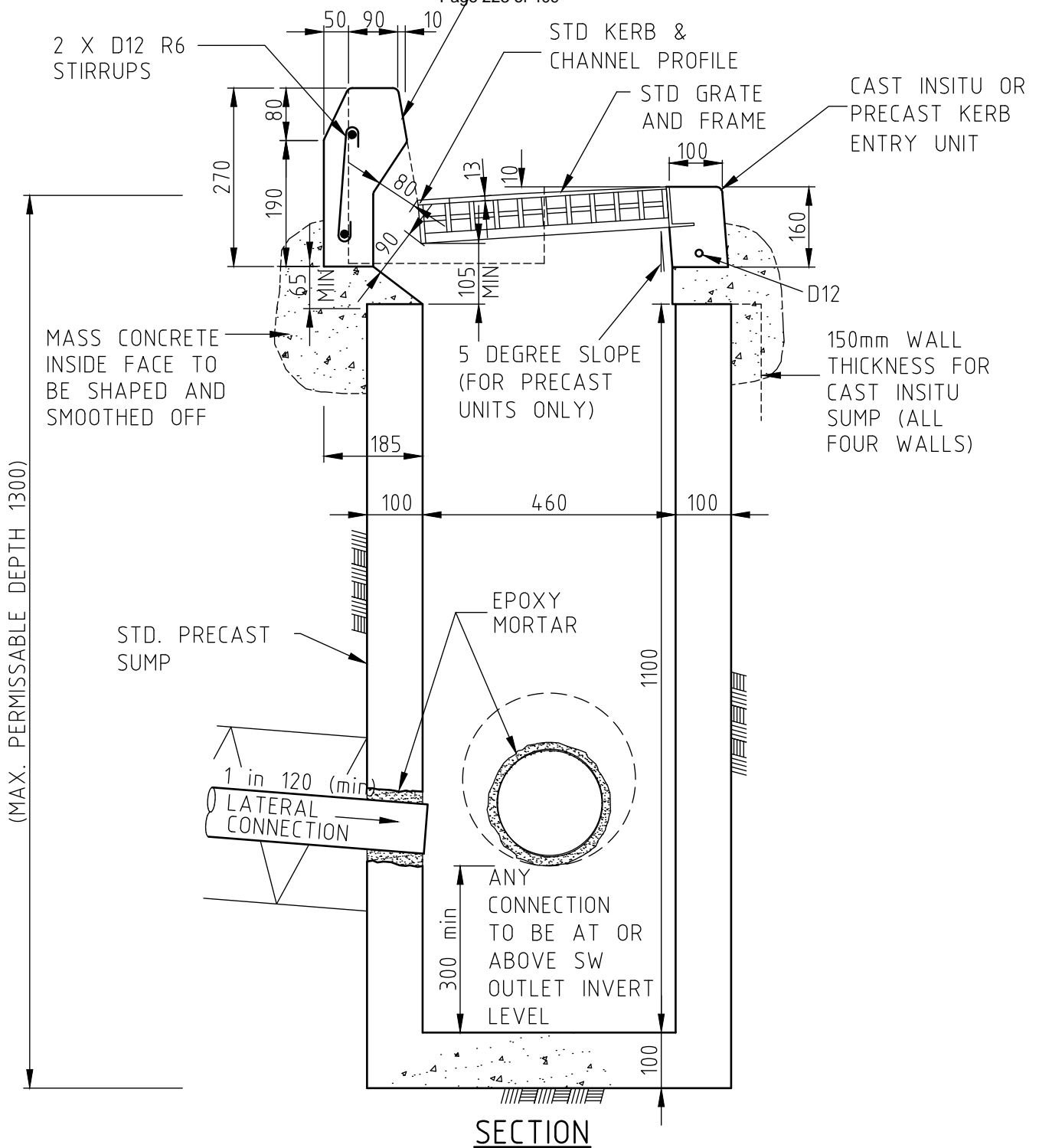

NELSON - TASMAN
LAND DEVELOPMENT MANUAL

515

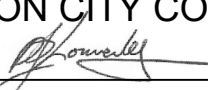

NOTES

1. SEE SHEET DRAWING 518 FOR DETAILS OF STD GRATING AND FRAME
2. INSITU CONCRETE TO BE 27.5 MPa AFTER 28 DAYS
3. NO REINFORCING REQUIRED FOR CAST INSITU BACK ENTRY UNIT
4. WHERE SUMP IS CONCRETED TO INTERCEPT K & C AT DISTINCT GRADE THE ENTRY UNIT SHALL BE INCLINED ON THE INSITU PAD EXTENDED OVER THE SUMP WALL WIDTH

NELSON CITY COUNCIL  GROUP MANAGER INFRASTRUCTURE, NELSON		BACK ENTRY SUMP IN STANDARD KERB & CHANNEL - SECTION (2 OF 2)	
TASMAN DISTRICT COUNCIL  ENGINEERING SERVICES MANAGER, TASMAN	DATE 01/07/19	NELSON - TASMAN LAND DEVELOPMENT MANUAL	516

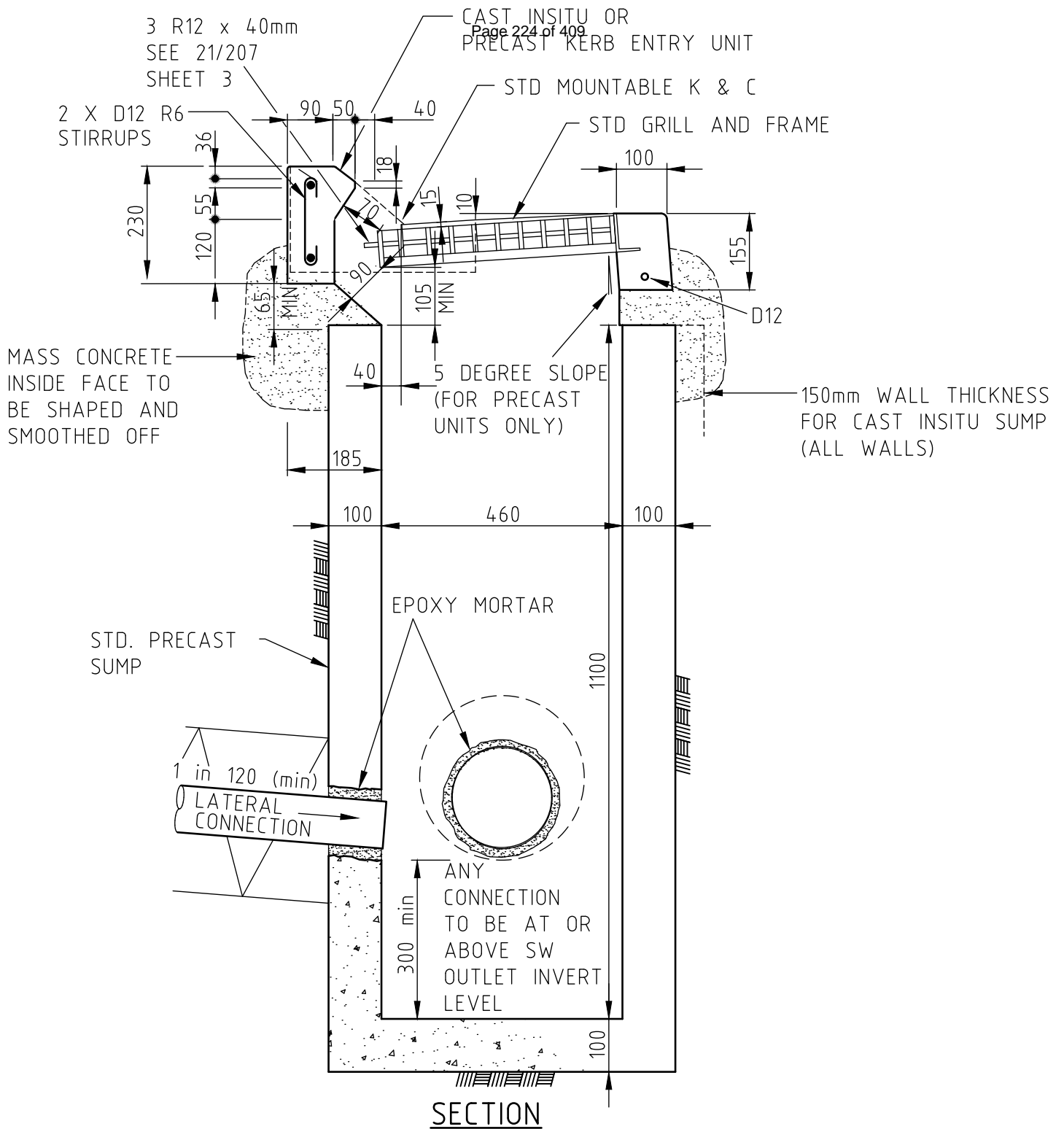

NOTES

1. SEE SHEET DRAWING 518 FOR DETAILS OF STD GRATING AND FRAME
2. INSITU CONCRETE TO BE 27.5 MPa AFTER 28 DAYS
3. NO REINFORCING REQUIRED FOR CAST INSITU BACK ENTRY UNIT
4. WHERE SUMP IS CONCRETED TO INTERCEPT K & C AT DISTINCT GRADE THE ENTRY UNIT SHALL BE INCLINED ON THE INSITU PAD EXTENDED OVER THE SUMP WALL WIDTH

<p>NELSON CITY COUNCIL</p> <p><i>[Signature]</i></p> <p>GROUP MANAGER INFRASTRUCTURE, NELSON</p>	<p>BACK ENTRY SUMP IN STANDARD MOUNTABLE KERB & CHANNEL</p>		
<p>TASMAN DISTRICT COUNCIL</p> <p><i>[Signature]</i></p> <p>ENGINEERING SERVICES MANAGER, TASMAN</p>	<p>DATE</p> <p>01/07/19</p>	<p>NELSON - TASMAN LAND DEVELOPMENT MANUAL</p>	<p>517</p>

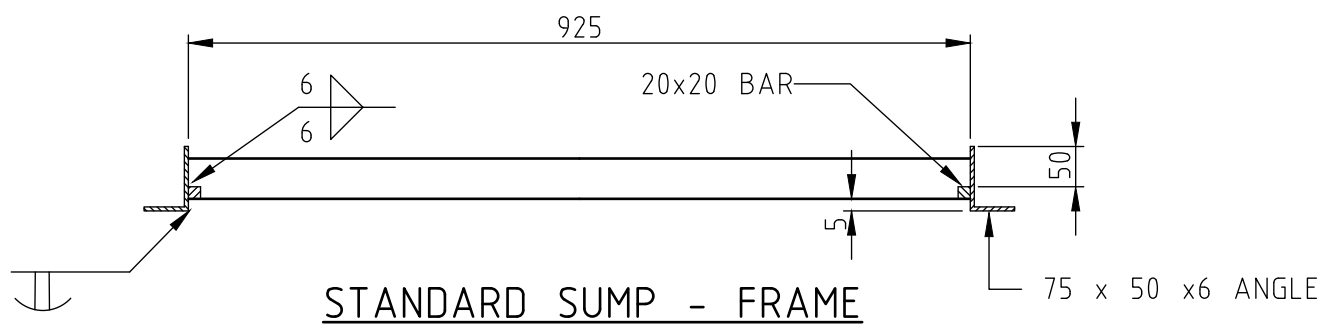
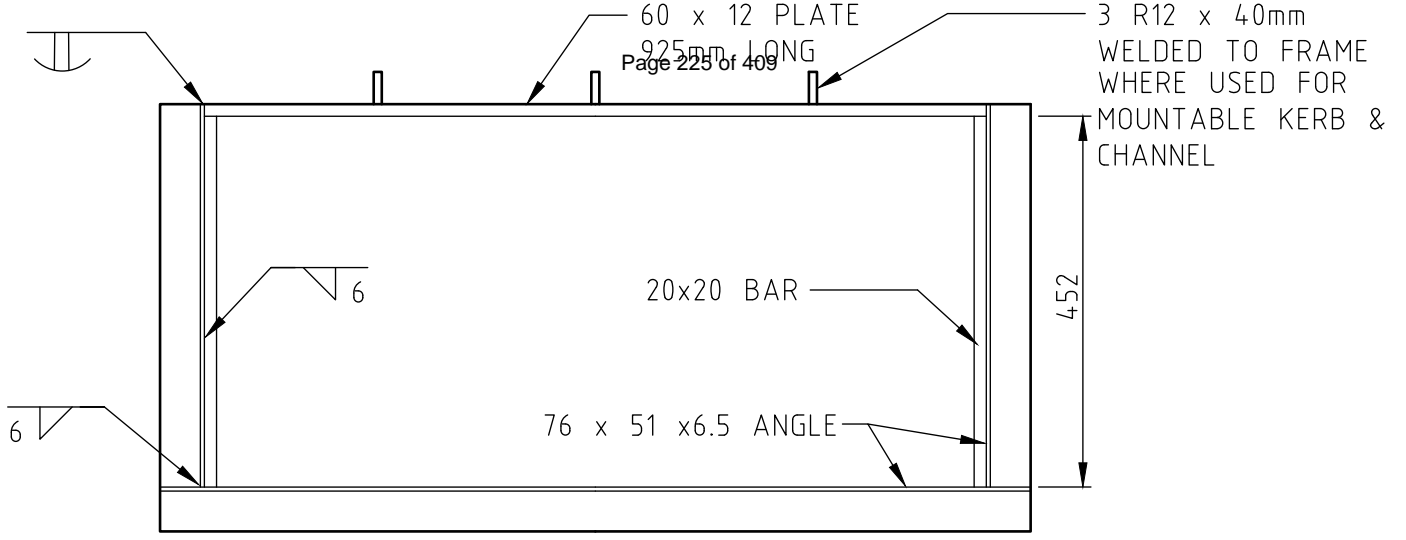

STANDARD SUMP - FRAME

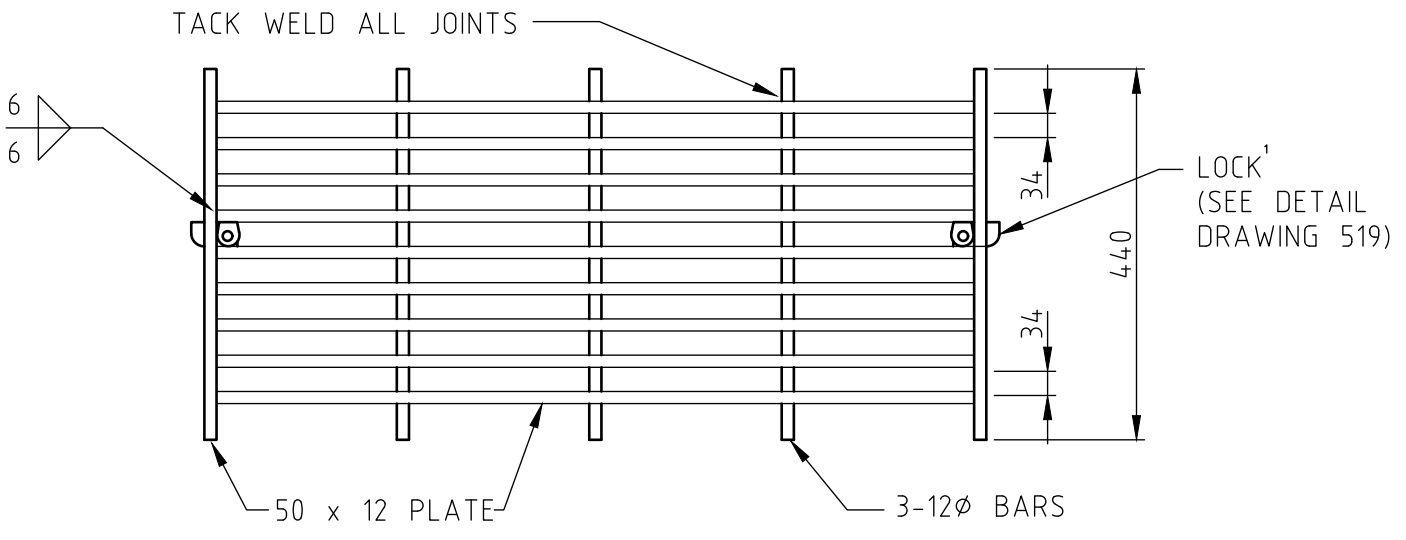

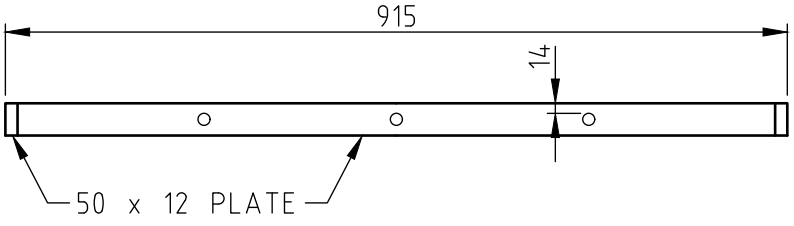

TACK WELD ALL JOINTS

LOCK¹
(SEE DETAIL DRAWING 519)

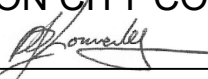

STANDARD SUMP - GRATING

NOTE
FRAME AND GRATE TO BE MILD STEEL

NELSON CITY COUNCIL  GROUP MANAGER INFRASTRUCTURE, NELSON		STANDARD SUMP FRAME & GRATE (1 OF 2)	
TASMAN DISTRICT COUNCIL  ENGINEERING SERVICES MANAGER, TASMAN		DATE 01/07/19	NELSON - TASMAN LAND DEVELOPMENT MANUAL
			518

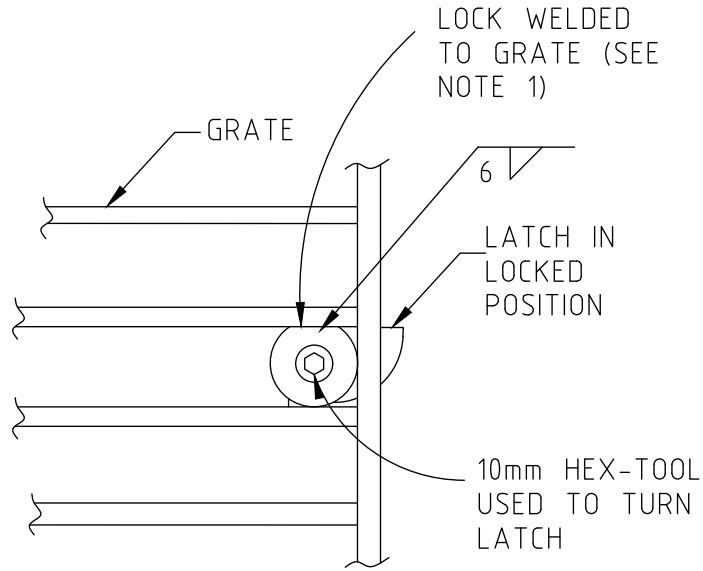

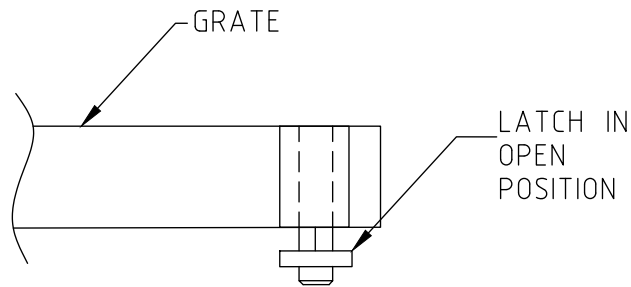

LOCK - PLAN VIEW



LOCK - ELEVATION

NOTES

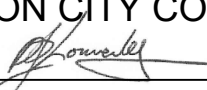
1. A LOCKING MECHANISM MUST BE INCORPORATED WITH ALL STANDARD SUMP GRATES. AN EXAMPLE OF A COUNCIL APPROVED LOCK IS THE "LOCK ASSEMBLY FOR USE WITH A GRATE" AS SHOWN ON THE NZ INTELLECTUAL PROPERTY OFFICE WEBSITE, CERTIFICATE OF REGISTRATION OF DESIGN NUMBER 418820. LOCKS OTHER THAN DETAILED ABOVE, MUST BE APPROVED BY COUNCIL BEFORE USE.
2. MARINE GREASE SHALL BE APPLIED TO ALL INTERNAL MOVING PARTS AFTER THE LOCK HAS BEEN FIXED TO THE GRATE

NELSON CITY COUNCIL  GROUP MANAGER INFRASTRUCTURE, NELSON		STANDARD SUMP - LOCK & TONGUE MECHANISM DETAIL (2 OF 2)	
TASMAN DISTRICT COUNCIL  ENGINEERING SERVICES MANAGER, TASMAN	DATE 01/07/19	NELSON - TASMAN LAND DEVELOPMENT MANUAL	519

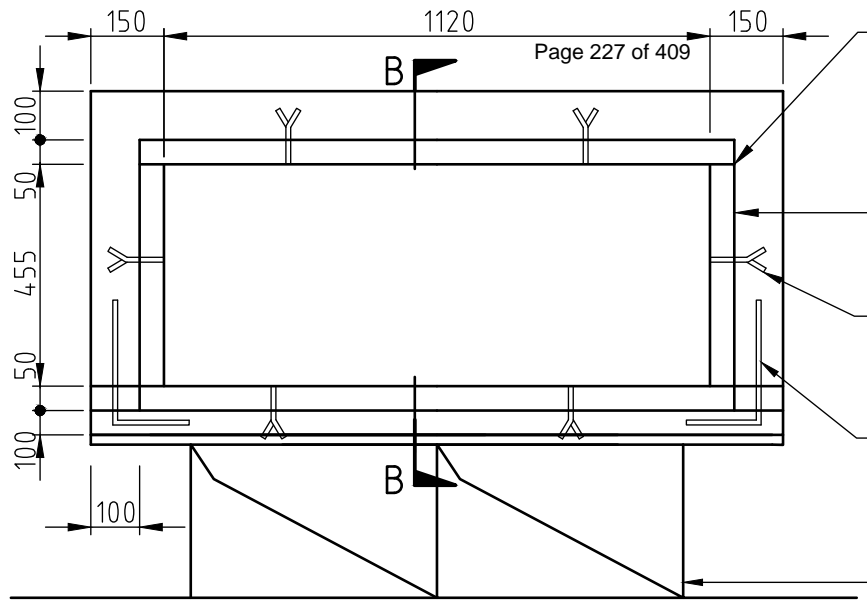

PLAN OF SUMP

- SHOP WELD STEEL FRAME
- 50x50 ANGLE SUPPORT FRAMING
- RAGGED END CONNECTOR :-
1 EACH END
2 EACH SIDE
- D12, 400 LONG SET 200 INTO EACH RAIL AND SUMP
- PRECAST FRONT KERB RAIL
- SHAPE CONCRETE ENTRANCE TO FLOW DIVERTER AND SUMP THROAT INSITU

REBATE SO THAT PLATE IS BELOW CONCRETE SURROUND
 EXTEND SUMP WALLS TO BERM OR FOOTPATH LEVEL

SEE DETAIL 1 (DRAWING 521)

SEE DETAIL 2 (DRAWING 521)

THROAT FLOAT-FINISH INSITU, TO GIVE MINIMUM THROAT OPENING HEIGHT OF 125mm

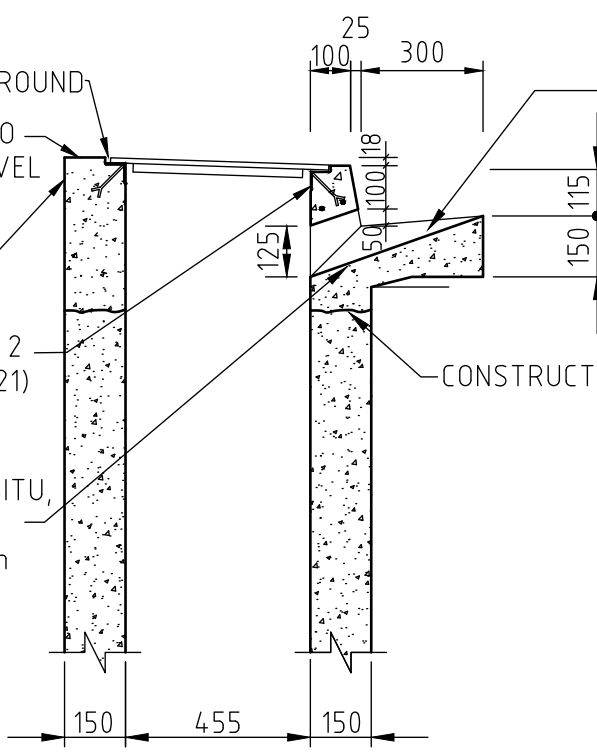

ENTRANCE SHAPED BY HAND INSITU. FLOW DIVERTER REQUIRED ON HILLSIDE KERBS ONLY

CONSTRUCTION JOINT

SECTION B-B

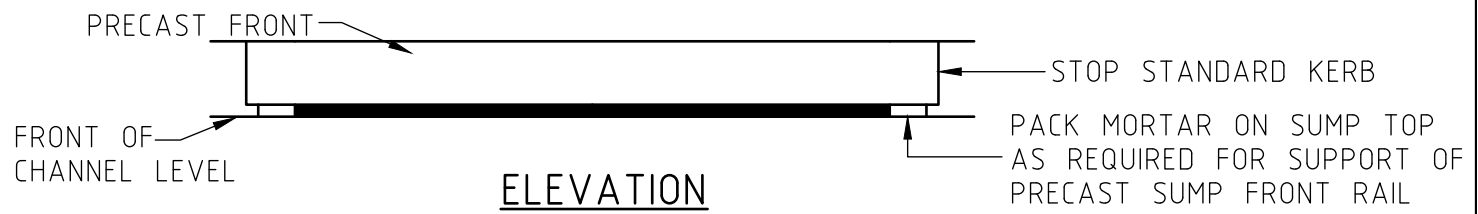

ELEVATION

NOTE

ALTERNATIVELY FOR VEHICLE LOADING 150mm THICK REINFORCED CONCRETE COVER SLAB WITH A PICTON TOP CAST IN MAY BE USED. THE REINFORCEMENT SHALL BE TO A SPECIFIC DESIGN.

NELSON CITY COUNCIL GROUP MANAGER INFRASTRUCTURE, NELSON	<h2 style="margin: 0;">BERM SUMP (1 OF 2)</h2>
--	--

TASMAN DISTRICT COUNCIL ENGINEERING SERVICES MANAGER, TASMAN	DATE 01/07/19	NELSON - TASMAN LAND DEVELOPMENT MANUAL	<h1 style="margin: 0;">520</h1>
--	-------------------------	--	---------------------------------

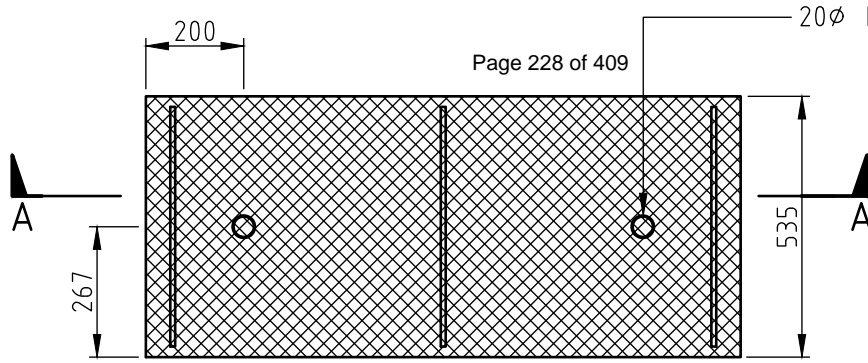

PLAN OF 6mm CHEQUER PLATE

NOTE

USE 2400x1200x6mm
CHEQUER PLATE SHEET
CUT 4 SHEETS 535x1200
CUT 30 RAGGED ENDS
100x40 EACH

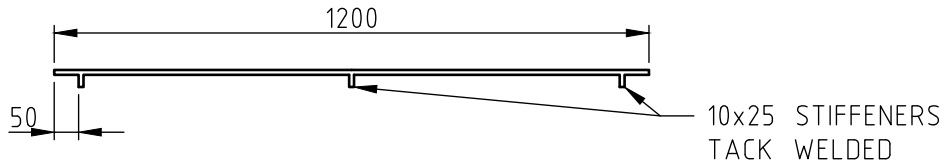

SECTION A-A

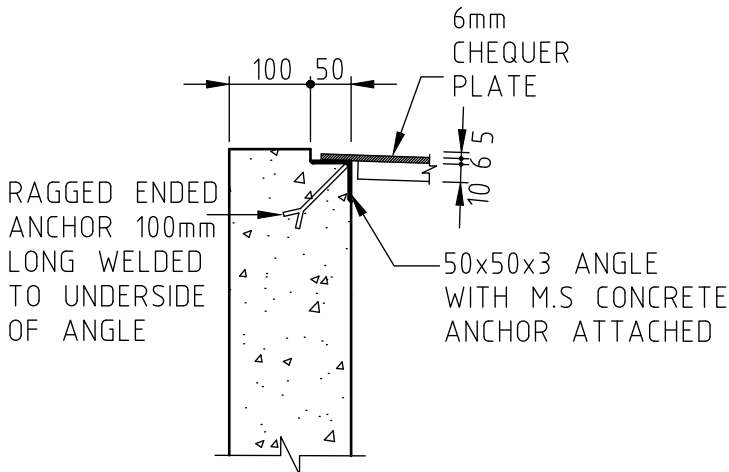

DETAIL 1

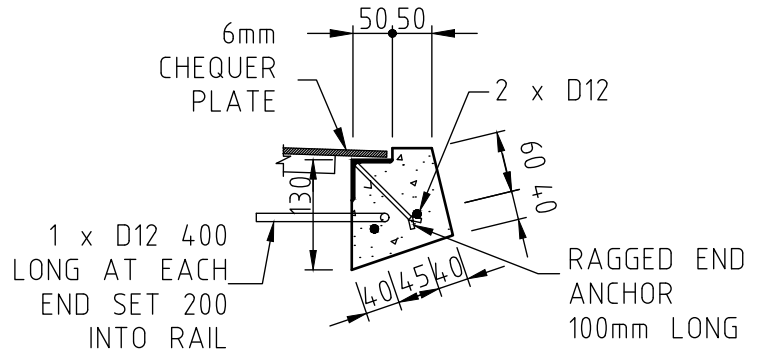

DETAIL 2

STANDARD COUNCIL SUMP

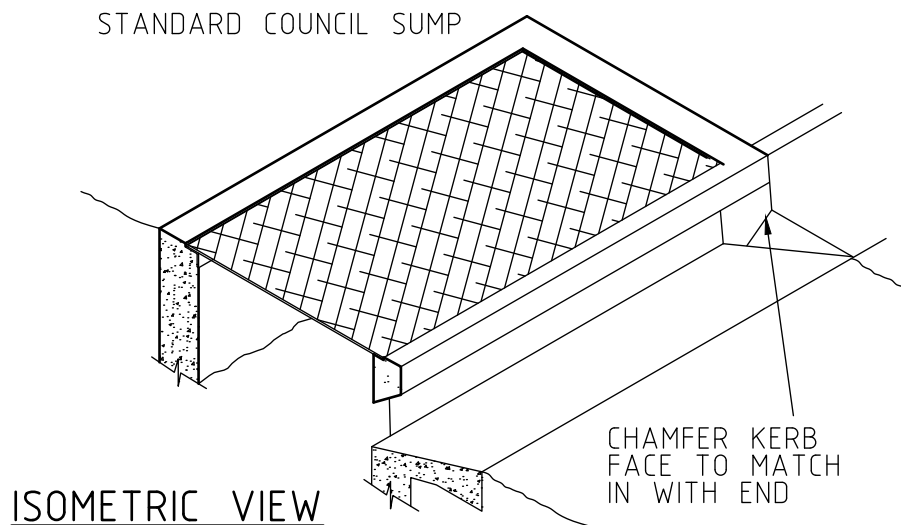

ISOMETRIC VIEW

NELSON CITY COUNCIL

[Signature]

GROUP MANAGER INFRASTRUCTURE, NELSON

**BERM SUMP - DETAILS
(2 OF 2)**

TASMAN DISTRICT COUNCIL

[Signature]

ENGINEERING SERVICES MANAGER, TASMAN

DATE

01/07/19

NELSON - TASMAN
LAND DEVELOPMENT MANUAL

521

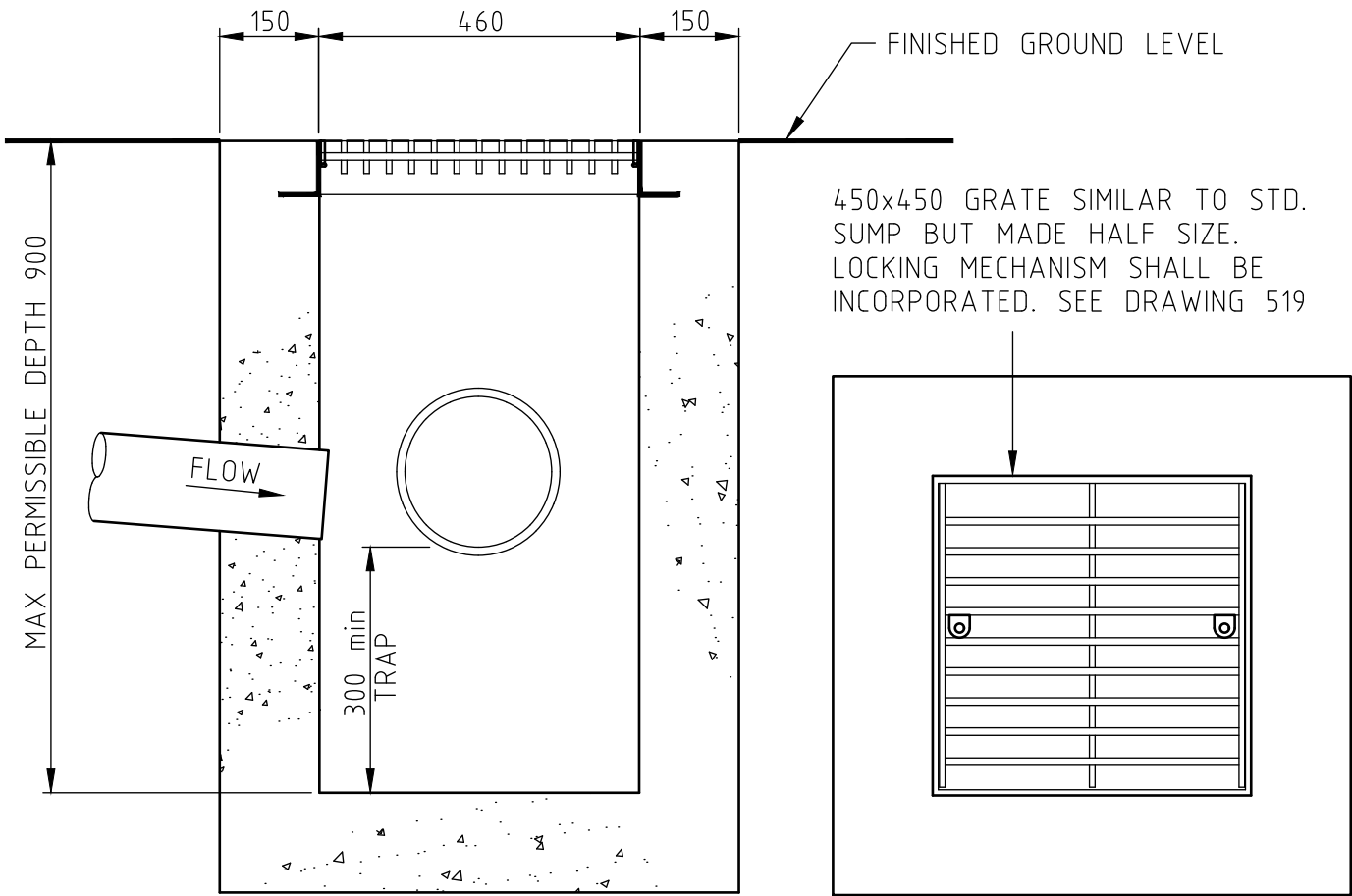

SECTION

PLAN

NOTE

WHERE PIPE DEPTH REQUIRES SUMP DEPTH IN EXCESS OF 900mm A STANDARD 940 x 460 mm SUMP SHALL BE PROVIDED.

NELSON CITY COUNCIL

[Signature]

GROUP MANAGER INFRASTRUCTURE, NELSON

YARD SUMP

TASMAN DISTRICT COUNCIL

[Signature]

ENGINEERING SERVICES MANAGER, TASMAN

DATE

01/07/19

NELSON - TASMAN
LAND DEVELOPMENT MANUAL

522

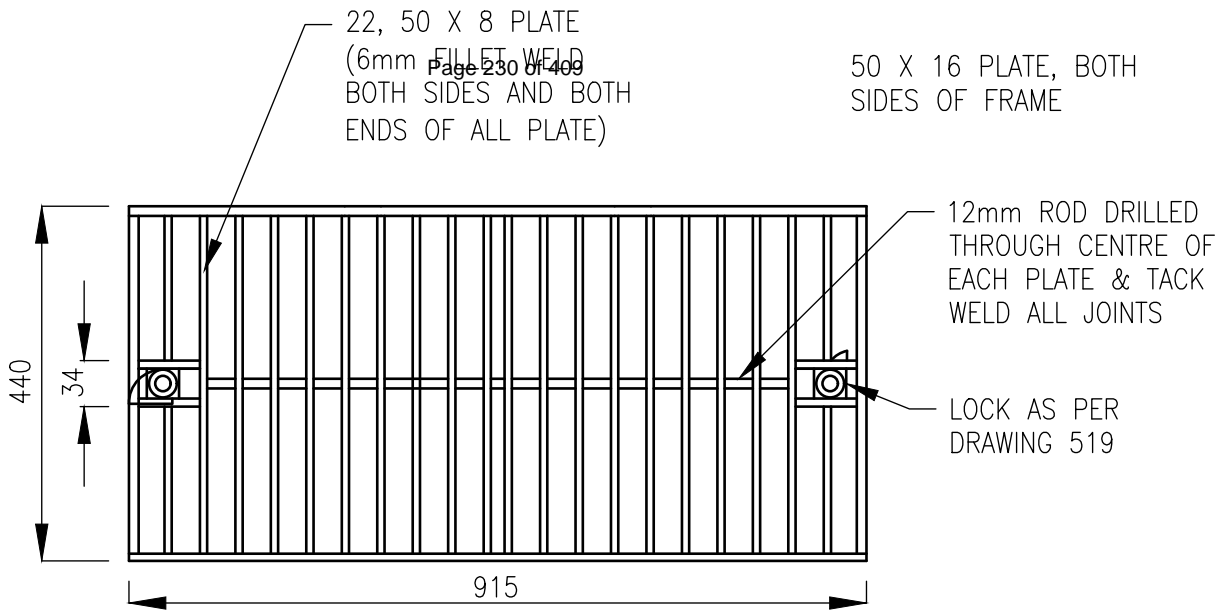

GRATE

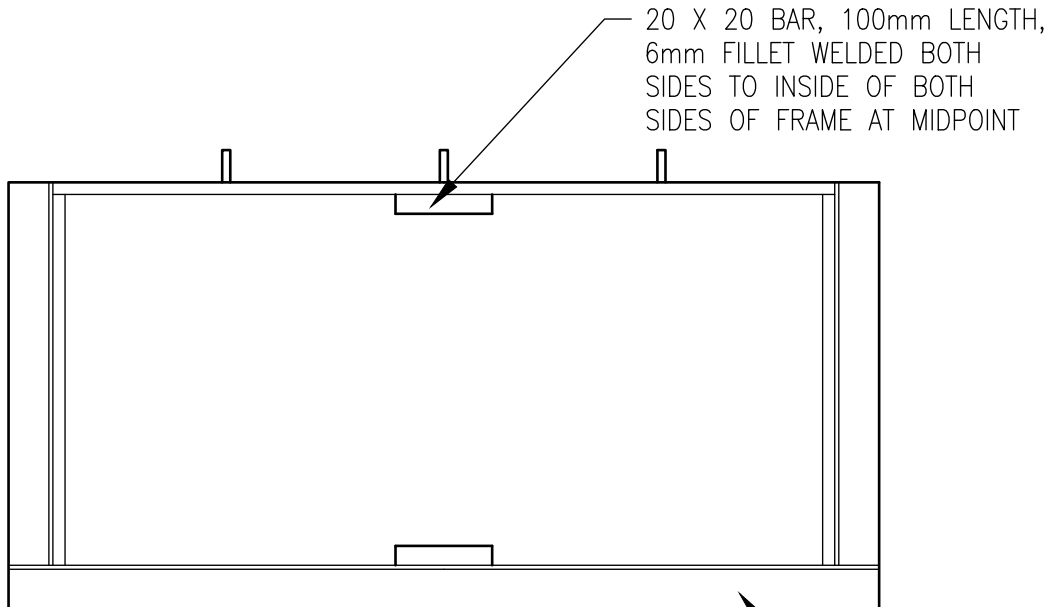

FRAME

FRAME AS PER
DRAWING 518

NOTES

1. LOCATION OF CYCLE FRIENDLY SUMP GRATE AT COUNCIL'S DISCRETION
2. GRATE TO BE MILD STEEL
3. LOCKING MECHANISM SHALL BE INCORPORATED, SEE DRAWING 519
4. DRAWING NOT TO SCALE

NELSON CITY COUNCIL

[Signature]
GROUP MANAGER INFRASTRUCTURE, NELSON

CYCLE FRIENDLY SUMP GRATE

TASMAN DISTRICT COUNCIL

[Signature]
ENGINEERING SERVICES MANAGER, TASMAN

DATE

01/07/19

NELSON - TASMAN
LAND DEVELOPMENT MANUAL

523

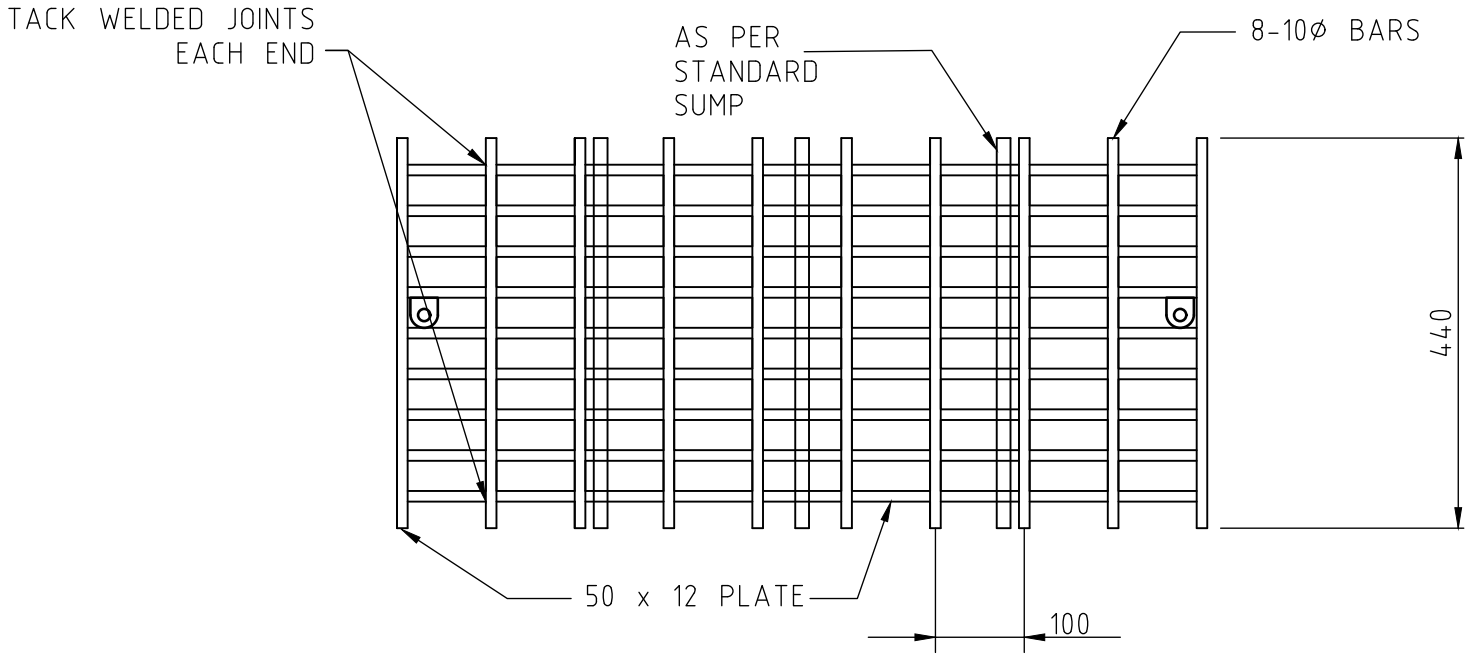

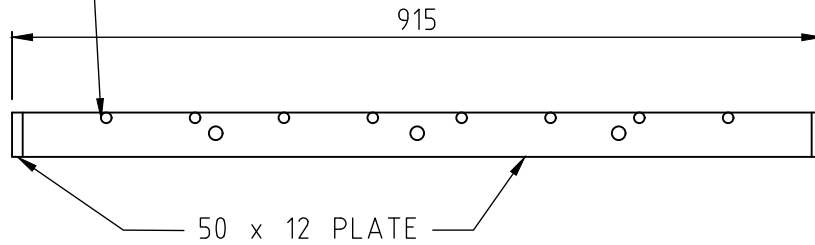

GRIND MAX 10mm DEEP INTO LONGITUDINAL PLATES. TOP OF LATERAL BARS TO BE FLUSH WITH TOP OF LONGITUDINAL PLATES



CYCLE FRIENDLY SUMP - GRATING

NOTES

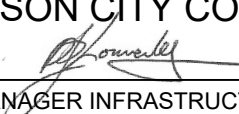
1. LOCATION OF CYCLE FRIENDLY SUMP GRATE AT COUNCIL'S DISCRETION
2. THE SUMP GRATE IS A STANDARD SUMP GRATE AS PER DRAWING 518, WITH THE ADDITION OF LATERAL BARS
3. FRAME AND GRATE TO BE MILD STEEL

<p>NELSON CITY COUNCIL</p>  <p>GROUP MANAGER INFRASTRUCTURE, NELSON</p>	<p>CYCLE FRIENDLY SUMP GRATE MODIFICATION OF STANDARD SUMP GRATE</p>		
<p>TASMAN DISTRICT COUNCIL</p>  <p>ENGINEERING SERVICES MANAGER, TASMAN</p>	<p>DATE 01/07/19</p>	<p>NELSON - TASMAN LAND DEVELOPMENT MANUAL</p>	<p>524</p>

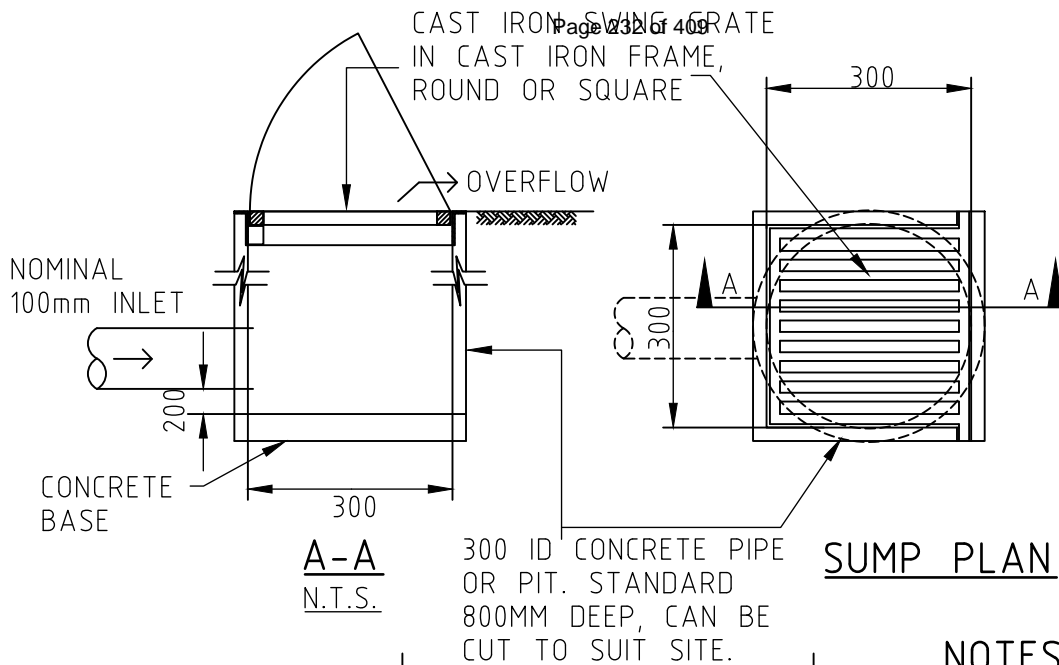

NOTES:

1. FINISHED FLOOR LEVEL MUST NOT BE LESS THAN 150mm HIGHER THAN LID LEVEL OF SUMP
2. SUMP IN ROADWAY MAY BE PERMITTED WHERE NOT POSSIBLE TO POSITION IN DRIVEWAY OR BERM

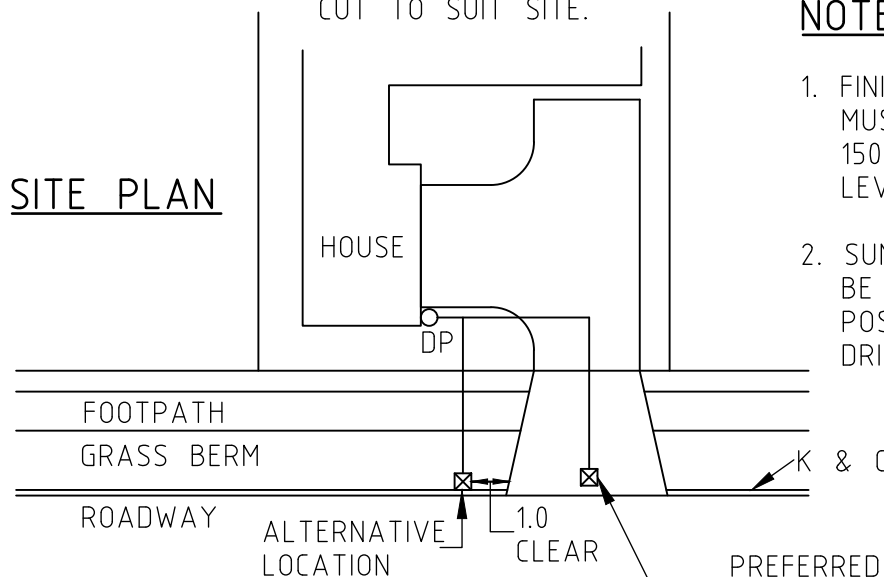

PREFERRED LOCATION OF SUMP IN VEHICLE CUTDOWN (ONLY WHEN FOOTPATH IS OFFSET FROM KERB)

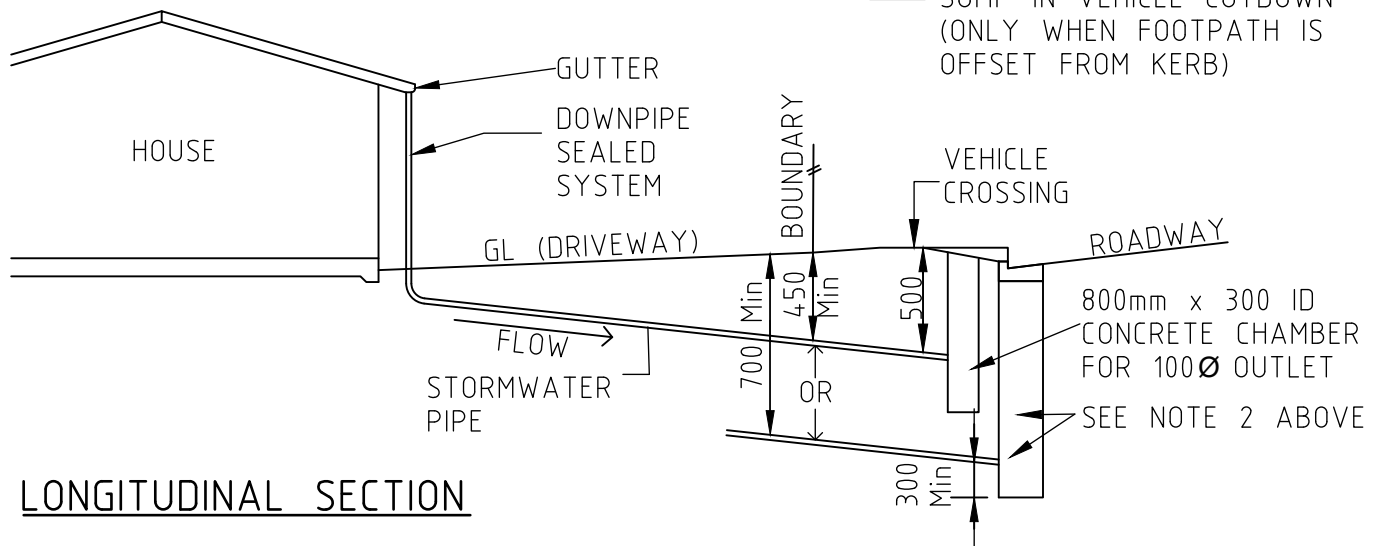

LONGITUDINAL SECTION

NELSON CITY COUNCIL GROUP MANAGER INFRASTRUCTURE, NELSON		INFILL BUBBLE - UP SUMP (SEALED HOUSE DOWNPIPE CONNECTION ONLY)	
TASMAN DISTRICT COUNCIL ENGINEERING SERVICES MANAGER, TASMAN	DATE 01/07/19	NELSON - TASMAN LAND DEVELOPMENT MANUAL	525

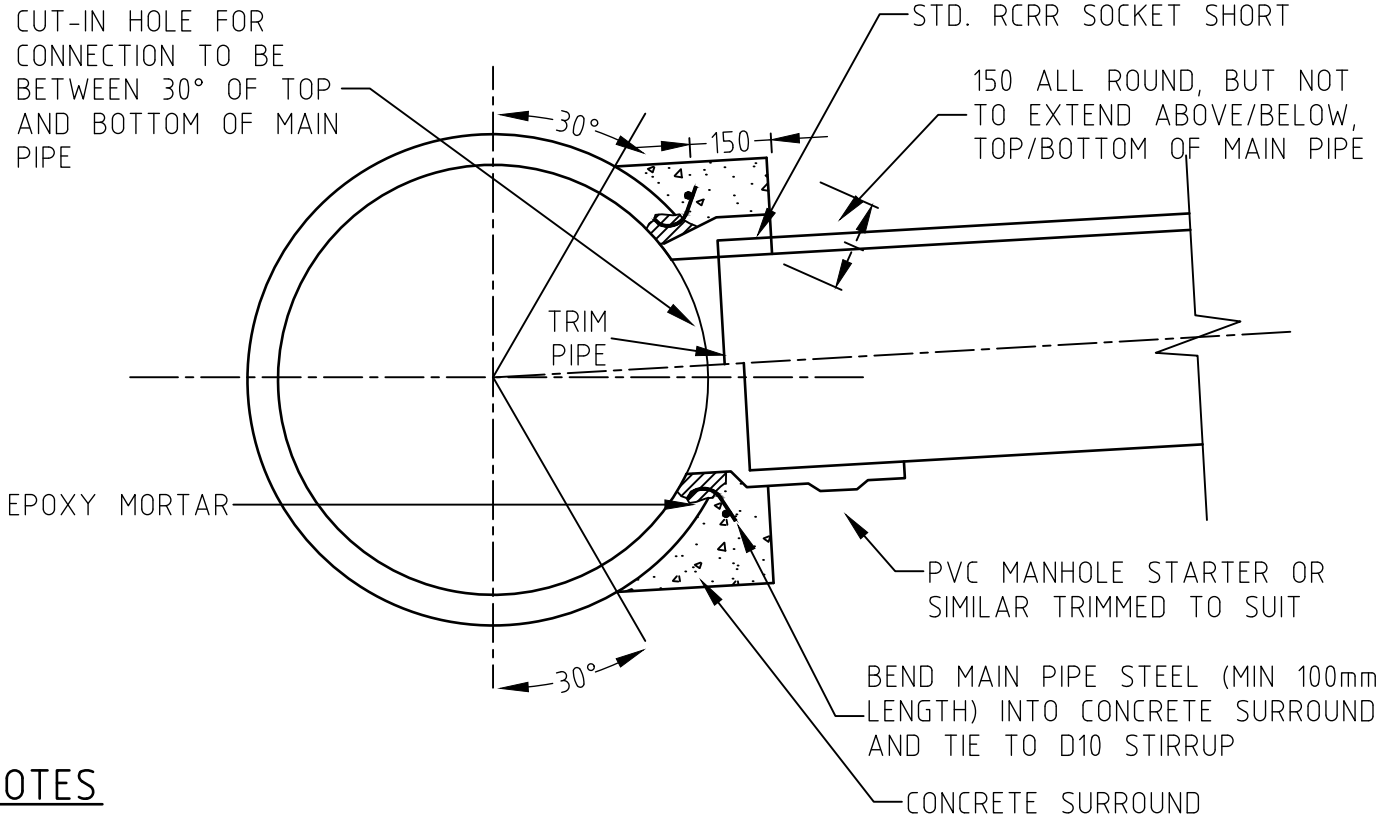

NOTES

1. SPECIAL DESIGN REQUIRED FOR: MAIN PIPES OTHER THAN REINFORCED CONCRETE, MORE THAN ONE CONNECTION PER MAIN.
2. DIRECT CONNECTIONS OF THIS TYPE ARE NOT PERMITTED ON PLASTIC MAINS.
3. OUTSIDE EDGE OF MAIN PIPE CUT-IN HOLE SHALL BE NOT LESS THAN 300mm FROM COLLAR OR END OF PIPE.
4. MAXIMUM DIAMETER OF CUT-IN HOLE SHALL BE LESS THAN TWO THIRDS OF THE INTERNAL DIAMETER OF MAIN PIPE.
5. EPOXY MORTAR SHALL BE APPLIED STRICTLY ACCORDING TO THE MANUFACTURER'S RECOMMENDATION AND SHALL BE FULLY CURED BEFORE THE SURROUND IS POURED AND THE SIDELINE LAID.
6. MAIN PIPE SURFACE SHALL BE ROUGHENED AND GROUT COATED BEFORE CONCRETE SURROUND IS POURED.
7. DIRECT CONNECTIONS MUST BE APPROVED BY THE ENGINEER, AND NORMALLY SHALL ONLY BE USED WHERE THE SIDELINE IS LESS THAN 10m LONG, AND ACCESS FOR CLEANING THE SIDELINE IS EASILY OBTAINABLE AT THE UPSTREAM END. THAT IS THE SIDELINE SHALL TERMINATE WITH A MANHOLE, LHCE OR SUMP.
8. DIAMETER OF SIDELINE PIPE SHALL BE LESS THAN HALF THE INTERNAL DIAMETER OF THE MAIN PIPE.

SQUARE RADIAL DIRECT CONNECTIONS

NOMINAL SIDELINE DIAMETER	MINIMUM MAIN PIPE DIAMETER
100	225
150	375
200	450
225/250	525
300	675
375	825
450	975
525	1050
600/675	1350
750	1600
825/900	1800
975	1950
1050	2100

<p>NELSON CITY COUNCIL</p> <p><i>[Signature]</i></p> <p>GROUP MANAGER INFRASTRUCTURE, NELSON</p>	<p>DIRECT CONNECTIONS TO STORMWATER PIPES</p>		
<p>TASMAN DISTRICT COUNCIL</p> <p><i>[Signature]</i></p> <p>ENGINEERING SERVICES MANAGER, TASMAN</p>	<p>DATE</p> <p>01/07/19</p>	<p>NELSON - TASMAN LAND DEVELOPMENT MANUAL</p>	<p>526</p>

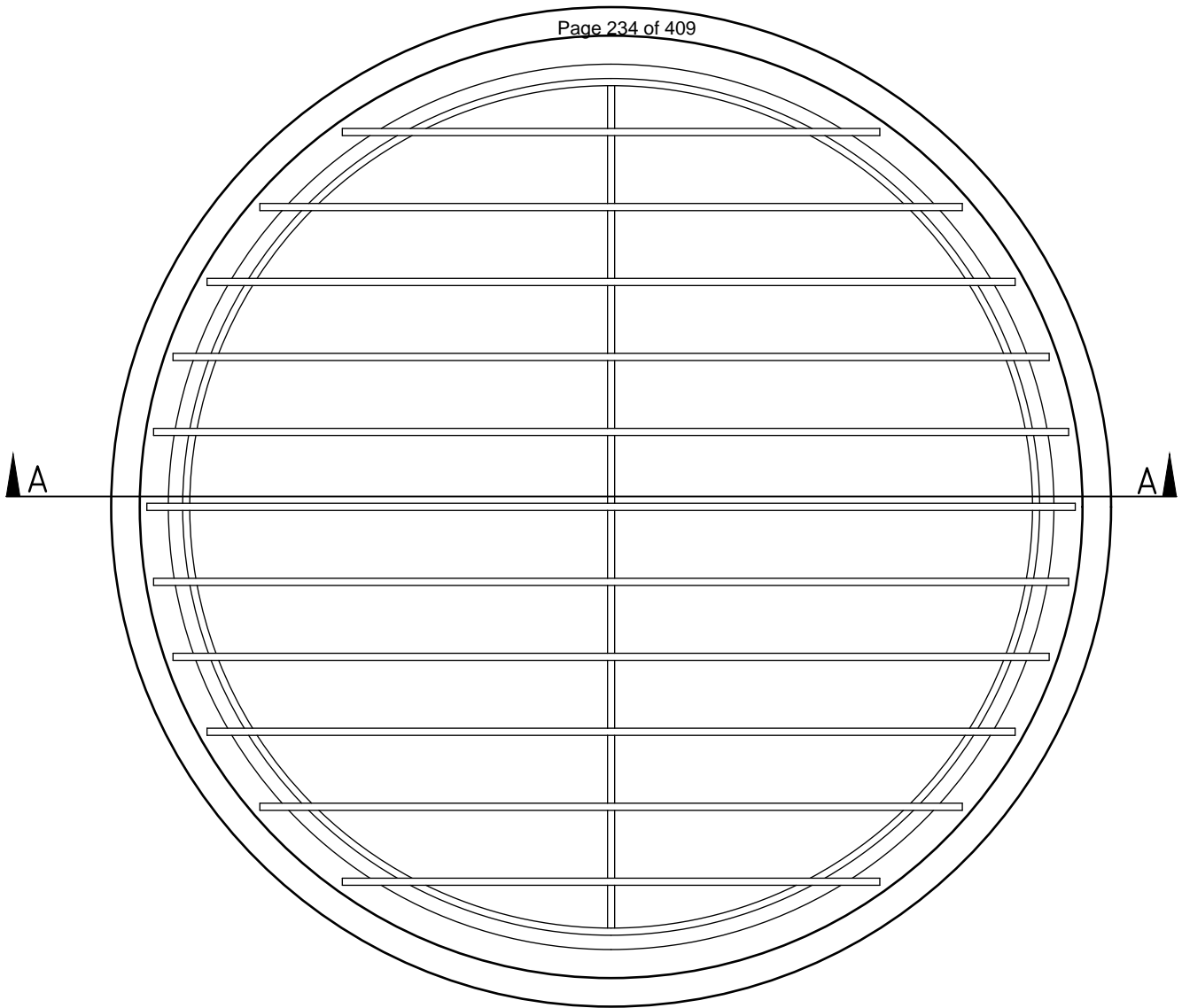

PLAN

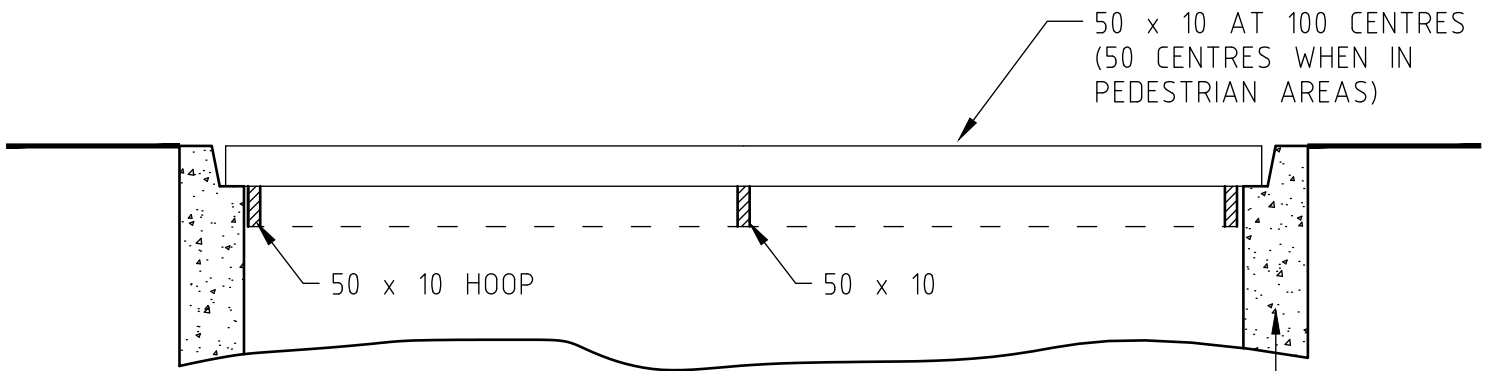

A-A

NOTE

1. DETAILS SHOWING THE FIXING DOWN OF THE GRILL TO THE MANHOLE LINER SHALL BE DETERMINED AT THE TIME OF DESIGN.

NELSON CITY COUNCIL

[Signature]
 GROUP MANAGER INFRASTRUCTURE, NELSON

DEBRIS TRAP GRILL

TASMAN DISTRICT COUNCIL

[Signature]
 ENGINEERING SERVICES MANAGER, TASMAN

DATE

01/07/19

NELSON - TASMAN
LAND DEVELOPMENT MANUAL

527



Chapter 6

Wastewater

TABLE OF CONTENTS

CHAPTER 6	WASTEWATER	1
INTRODUCTION		1
6	PURPOSE	1
6.1	Performance Outcomes	1
6.2	Referenced Documents	1
6.2.1	Regional Plan Requirements	1
6.2.2	Building Consent	1
6.2.3	External Standards	2
STANDARDS		3
6.3	Reticulation Design	3
	Mandatory Matters	3
6.3.1	General	3
6.3.2	Connections	4
6.3.3	Trade Waste	4
	Good Practice	5
6.3.4	General	5
6.3.5	Stormwater	5
6.4	Layout and Alignment of Reticulation	5
	Mandatory Matters	5
6.4.1	General	5
6.4.2	Reticulation in Roads	5
6.4.3	Reticulation through Private Property	6
6.4.4	Easements for Wastewater Reticulation	6
6.4.5	Crossing other services	6
	Good Practice	6
6.4.6	Alignment of Reticulation	6
6.5	Pipe Design	7
6.5.1	Pressure Reticulation Pipe Material	7
6.5.2	Calculation of Flow	7
6.5.3	Area/Zoning Coefficients	7
6.5.4	Pipe Size for Gravity Sewer	8
6.5.5	Reuse of Existing Service Connections	8
6.5.6	Disconnections	9
6.5.7	Grades and Velocities	9
6.5.8	Pipe Cover	9
	Good Practice	11
6.5.9	Gravity Pipe Material	11
6.5.10	Calculation of Flow	11
6.5.11	Wastewater Area/Zoning Coefficients	12
6.5.12	Grades and Velocities	12
6.5.13	Pipe Cover	12
6.6	Seismic Design and Liquefaction	12
	Mandatory Matters	12

6.6.1	General	12
	Good Practice.....	13
6.6.2	General	13
6.7	Access points	13
	Mandatory Matters	13
6.7.1	Concrete Manholes.....	13
6.7.2	Thermoplastic Manholes.....	14
6.7.3	Rodding Points (Lamphole Cleaning Eyes)	14
6.7.4	Inspection 'T'	15
	Good Practice.....	15
6.7.5	Concrete Manholes.....	15
6.8	Pumping Stations.....	15
	Mandatory Matters	15
6.8.1	Pump Station Design	15
6.8.2	Access and Services.....	16
6.8.3	Electrical Equipment	17
6.8.4	Private Pumping Stations.....	18
6.8.5	Wastewater Pressure Rising Mains	18
6.8.6	Commissioning	18
	Good Practice.....	19
6.8.7	General	19
6.9	Reticulation Construction and Installation.....	19
6.9.1	Trenching	19
	Mandatory Matters	19
6.9.2	Trench Width.....	19
6.9.3	Base of Excavation	19
6.9.4	Trench Support	19
6.9.5	Dewatering	20
6.9.6	Metal Bedding	20
6.9.7	Pipe Embedment	20
6.9.8	Installation of Geotextiles.....	21
6.9.9	Water-stops and Trench Groundwater	21
6.9.10	Pipe Installation.....	21
	Good Practice.....	23
6.9.11	General	23
6.9.12	Water-stops and trench groundwater	23
6.10	Trenchless Technology	23
	Mandatory Matters	23
6.10.1	General	24
	Good Practice.....	25
6.10.2	General	25
6.11	Manhole Construction	26
	Mandatory Matters	26
6.11.1	Concrete Manholes.....	26
6.11.2	Installation of Thermoplastic Manholes	26
6.12	Tracer Tape.....	27
	Mandatory Matters	27
6.12.1	Tape Location, Tape Type and Tape Installation	27
6.12.2	Tracer Wire	27
6.12.3	Testing	27

6.13 Valve painting	27
Good Practice.....	28
6.13.1 General	28
6.14 Testing	28
Mandatory Matters	28
6.14.1 General	28
6.14.2 Air or Pressure Testing (for Non-Pressure Pipelines)	28
6.14.3 Hydrostatic Test – NZS 4404:2010, Appendix C, C2. 2 ‘Hydrostatic test’	28
6.14.4 Pressure Pipelines	29
6.14.5 Closed-circuit Television Inspection (CCTV)	29
6.14.6 Low Pressure Sewerage Pumping Systems.....	29
6.14.7 Low Pressure Pump Station Non-Residential Zoning (Industrial and Commercial)	29
6.14.8 Testing – General	30

LIST OF TABLES

Table 6-1 Wastewater Standards	2
Table 6-2 Wastewater Area/Zoning Coefficients.....	8
Table 6-3 Minimum Velocity and Grade Requirements	9
Table 6-4 Minimum Cover	10
Table 6-5 Pipe Stiffness Required for uPVC Pipe for Gravity Applications	11
Table 6-6 Water Stop Spacings	21

CHAPTER 6 WASTEWATER

INTRODUCTION

6 PURPOSE

The purpose of this section is to outline Council's requirements for the provision of wastewater reticulation. The Standards aim to provide for the collection and disposal of wastewater to a Council-owned treatment and disposal facility. The reticulation must address health and safety, water quality and whole-of-life efficiency and effectiveness, regardless of the size and scale of development.

6.1 Performance Outcomes

Performance outcomes for wastewater network assets sought by these standards are set out below. They are subject to the objectives, policies and rules of the Nelson and Tasman RMPs:

- a) Wastewater reticulation that ensures human health and safety;
- b) Connectivity to or compatibility with existing networks;
- c) Reticulation that allows for future development within the catchment or adjoining catchments;
- d) Reticulation that provides individual connection for all newly created allotments;
- e) Reticulation that is affordable, including maintenance and operations, replacement and renewal costs of the whole-of-life of the system;
- f) Accessibility for maintenance and repair works, with a minimum of disruption;
- g) A system that avoids ingress and egress from stormwater drainage.

All performance outcomes are also subject to the applicable RMP objectives and policies and appropriate wastewater supply bylaws, which take precedence over the requirements of the Nelson Tasman Land development Manual (NTLDM).

6.2 Referenced Documents

6.2.1 Regional Plan Requirements

The standards set out in this chapter address matters that are specific to Council asset creation or activities that may have an impact on an asset. They are subject to the respective Nelson and Tasman RMPs. Key sections of the Plans that may be relevant to wastewater management asset design and construction are subdivision and discharge provisions.

6.2.2 Building Consent

As well as the requirements of the NTLDM, the Building Act and NZ Building Code (NZBC) requirements also apply to individual connections to Council's wastewater reticulation. A building consent application is required and is to be supported with the appropriate plans and specifications (Section 45 of the Building Act 2004). These must demonstrate compliance with the performance requirements of NZBC clause G13 ("foul water").

The information required includes, but is not limited to, the size, fall (gradient) and setting out of the proposed drainage, details of access points for maintenance, provision for ventilation and proximity to any buildings.

6.2.3 External Standards

Unless otherwise specified within the standards of this document, wastewater networks will be designed and constructed in a manner consistent with the standards set out in Table 6-1. Where an Act or National Standard document is referenced, this will be the current version including any associated amendments.

Table 6-1 Wastewater Standards

Standard	Comment
AS/NZS 1260	PVC-U Pipes and fittings for drain, waste and vent applications
AS/NZS 2032	Installation of PVC pipe systems
AS/NZS 2566	Buried flexible pipelines – Structural design and Installation
AS/NZS 4158	Thermal-bonded polymeric coatings on valves and fittings for water industry purposes
AS/NZS 4998	Bolted unrestrained mechanical couplings for waterworks purposes
AS/NZS 2280	Ductile iron pipes and fittings
AS/NZS 4441	Oriented PVC (PVC-O) pipes for pressure applications
NZS 4442	Welded steel pipes and fittings for water, sewage and medium pressure
AS/NZS 1477	PVC Pipes and fittings for pressure applications
AS 1646	Elastomeric seals for water works purposes
AS/NZS 4058	Pre-cast concrete pipes (pressure and non-pressure)
AS/NZS 3725	Design for installation of buried concrete pipes
AS/NZS 4130	Polyethylene (PE) pipes for pressure applications
AS/NZS 5065	Polyethylene and polypropylene pipes and fittings for drainage and sewerage applications
BS 3412	PE materials for moulding and extrusion
AS/NZS 2033	Installation of polyethylene pipe systems
AS 3572	Glass filament reinforced plastics
AS 3996	Access covers and grates
NZS 7643	Code of Practice for the installation of unplasticized PVC pipe systems
NZS 3109	Concrete construction
NZS 3121	Water and aggregate for concrete
NZS 4404	Land development and subdivision infrastructure
AS/NZS 1547	On-site domestic-wastewater management
AS/NZS 1546	
www.astt.com. au	Australian Society of Trenchless Technology

Standard	Comment
Ministry of Business, Innovation & Employment	NZ Building Code - G13, G14 and B2
Water New Zealand	NZ Infiltration and Inflow Control Manual New Zealand Pipe Inspection Manual 3rd edition
Bylaw	Nelson City Council and Tasman District Council Wastewater Bylaw (current at the time of development)

STANDARDS

6.3 Reticulation Design

This section sets out Council's expectations for general design standards for wastewater reticulation, including private connections, trade waste and reticulation layout.

Mandatory Matters

Council requires the following standards to be met in the design of the wastewater supply reticulation.

6.3.1 General

- 6.3.1.1 Wastewater disposal will be provided to every lot by means of a connection to a reticulated wastewater system.
- 6.3.1.2 All systems will be designed to accommodate the flow from upstream of the subdivision or development and will be of sufficient capacity to provide for maximum flow from possible future development.
- 6.3.1.3 The Designer will eliminate retention of wastewater in piped systems and potential for wastewater to become anaerobic and produce gases by:
 - a) making use of adequate grades for self-cleansing and slime control;
 - b) avoiding use of wastewater pumping stations where possible;
 - c) ensuring adequate ventilation of stale wastewater; and
 - d) avoiding any unnecessary turbulence at junctions and changes in grades, particularly where rising mains enter the gravity system at drop junctions.
- 6.3.1.4 In specific circumstances, individual lot low-flow pressure pumping systems that comply with Council's requirements will be permitted.
- 6.3.1.5 Under no circumstances will wastewater reticulation be connected to stormwater reticulation or drains.
- 6.3.1.6 Wastewater reticulation will be provided for the full length of each new road/street, unless approved otherwise by Council.
- 6.3.1.7 Under no circumstances will glue joints be permitted to be used in jointing straight lengths of pipe.

6.3.2 Connections

- 6.3.2.1 Council responsibility does not extend to private connections within the lot, private pumping systems and rising mains, which remain the responsibility of the users they serve.
- 6.3.2.2 No new reticulation is to be connected to Council existing operational reticulation unless the new reticulation has been checked and is free of all debris materials.
- 6.3.2.3 In all subdivisions, a 100mm minimum diameter wastewater connection will be provided to at least 1.0m inside the boundary of every lot with an inspection tee installed on the road side of the boundary - before it connects to the private sewer lateral.
- 6.3.2.4 Wastewater laterals, pipes and end caps will be painted red (stormwater will be painted green), see SD611 for the inspection tee at the boundary.
- 6.3.2.5 The end of each lateral will be marked by a 75mm x 25mm ground-treated marker stake suitably identified and partly painted red.
- 6.3.2.6 Pipes will be laid to achieve a minimum cover of 600mm at the boundary and be deep enough to provide gravity service from the building site.
- 6.3.2.7 Each connection will be adequate to serve the lot and to have a self-cleansing velocity flowing full.
- 6.3.2.8 The minimum lid level of any gully trap for all new dwellings will not be less than 150mm above the lid level of the manhole on the public wastewater sewer immediately upstream of the lateral connection.
- 6.3.2.9 To be classified as public wastewater, reticulation must be inspected, approved and designated as such by Council.

6.3.3 Trade Waste

- 6.3.3.1 Any proposal to discharge contaminated stormwater to the wastewater network will require a Trade Waste application.
- 6.3.3.2 To ensure uncontaminated stormwater does not enter the wastewater system, any area being served by the silt and oil trap must be roofed and have a low bund around the perimeter with a minimum height of at least 50mm.
- 6.3.3.3 For premises where food is prepared, a grease trap will be provided. The grease trap will meet the requirements of the New Zealand Building Code G13 acceptable solution 2 type in ground grease trap.
- 6.3.3.4 An application to Council for a Trade Waste approval will be required. Building consents are required for all works together with a monitoring programme.
- 6.3.3.5 In respect of Trade Waste, Council will be notified if the premises changes discharge practices.

Good Practice

The following matters provide additional direction and guidance in the design of the wastewater supply reticulation.

6.3.4 General

- 6.3.4.1 Increased use of an existing wastewater reticulation may require upgrading of a downstream-reticulation to prevent surcharging of the network.
- 6.3.4.2 Ventilation of reticulation manholes and pumping stations may be required.
- 6.3.4.3 In certain circumstances glue joints may be permitted on fittings with the written approval of the Engineer.
- 6.3.4.4 In some locations, a gravity connection may not be possible and the discharge may have to be pumped to the wastewater reticulation. This will require specific design showing the pumping system discharging into a chamber before entering the gravity connection point and approval via a building consent.

6.3.5 Stormwater

- 6.3.5.1 To prevent stormwater from entering the wastewater system, an appropriate mechanically or electronically operated wastewater diversion system may be required.

6.4 Layout and Alignment of Reticulation

This section sets out Council's expectations for the location of wastewater services and includes standards that relate to wastewater in road reserve, private property, easements and the crossing of other services.

Mandatory Matters

Council requires the following standards to be met in the layout and location of wastewater reticulation:

6.4.1 General

- 6.4.1.1 Wastewater reticulation will be aligned within public areas such as roads wherever possible.

6.4.2 Reticulation in Roads

- 6.4.2.1 Wastewater reticulation in roads will be aligned parallel to kerb lines within the carriageway to ensure that they do not clash with other services or occupy the full carriageway width.
- 6.4.2.2 Wastewater manholes will not be located adjacent to kerb and channel or at low points in the finished ground surface to minimise the possibility of surface water infiltration into the wastewater system.
- 6.4.2.3 Adequate clearance from other services and kerb lines will be maintained to allow for:
 - a) Excavation on existing services;
 - b) The future relaying of the drains; and

- c) The provision of additional future services.

6.4.2.4 In curved roads, reticulation will generally follow the road alignment in straight lines on such alignment that the reticulation does not occupy the full carriageway width.

6.4.3 Reticulation through Private Property

6.4.3.1 The catchment area to be served by public wastewater reticulation aligned through private property will be kept to an absolute minimum.

6.4.3.2 In planning the layout of wastewater reticulation through private property consideration will be given to preserving access to the pipelines for:

- a) Maintenance purposes;
- b) Preserving the route for relaying the reticulation in the future; and
- c) Avoiding likely positions for buildings, garages, carports and retaining walls.

6.4.3.3 Where, as part of a subdivision or development, existing and/or proposed public wastewater reticulation will be located in private property, an easement will be required in favour of the Council.

6.4.4 Easements for Wastewater Reticulation

6.4.4.1 The width of easement will be central on the centre line of the reticulation and calculated as the general easement width of 3m, plus the diameter of the pipe and the pipe depth of the excavation. (Or at the discretion of the Engineering Manager)

6.4.4.2 The standard wording required on the Easement Document will be:

“Memorandum Easement in Gross will be provided in favour of the respective Council to convey sewage in a pipe and to provide unrestricted access along the line of the pipe for maintenance and renewal work.”

6.4.5 Crossing other services

6.4.5.1 Diagonal crossing of other services, including kerb lines and boundaries or fence lines, at acute angles less than 45 degrees will be avoided wherever possible.

Good Practice

The following matters provide additional direction and guidance in the layout and location of wastewater reticulation:

6.4.6 Alignment of Reticulation

6.4.6.1 The preferred alignments of Wastewater reticulation on private property is:

- a) Within rights-of-way (RoWs) or driveways;
- b) Outside probable building envelopes (northern side of dwelling);
- c) Clear of fence lines and kerb lines;
- d) Adjacent to boundaries; and/or
- e) Parallel to boundaries.

6.5 Pipe Design

This section sets out Council's requirements for design of wastewater supply reticulation pipes.

Mandatory Matters

Council requires the following standards to be met in the design of all pipe work that makes up the wastewater reticulation:

6.5.1 Pressure Reticulation Pipe Material

- 6.5.1.1 All public pressure wastewater reticulation will be PE 100 pipes complying with AS/NZS4130. All pressure reticulation should be subject to specific design for cyclic dynamic stresses (fatigue), in selection of pipe pressure class and complying with PIPA Technical Guidelines: POP010A Polyethylene Pipes – Design for dynamic stresses; and POP010B Fusion Fittings for use with Polyethylene Pressure Pipes – Design for Dynamic Stresses.
- 6.5.1.2 For pressure sewer rising mains, the design will consider GRB to AS 3571.1, or PVC-O to AS/NZS4441. These products are not subject to or highly resistant to fatigue and are commonly used internationally for this purpose.

6.5.2 Calculation of Flow

- 6.5.2.1 The parameters for calculating the design flow from residential catchments are:
- Average dry weather flow (ADWF) = 225 litres per day per person;
 - Number of people per dwelling = 2.5;
 - Dry weather diurnal peaking factor (PF) = 2;
 - Dilution/infiltration factor for wet weather = 3;
 - Therefore, the peak wet weather flow (PWWF) is equivalent to 6 times the ADWF;
 - Flows should be based upon an 18-hour day.

6.5.3 Area/Zoning Coefficients

- 6.5.3.1 For catchments of mixed zones or where the number of potential dwellings is not known, wastewater flows will be calculated using the area/zoning coefficients given below in Table 6-2. The 'area' is that area within a zone comprising lots, roadways, esplanade reserves and neighbourhood parks. Major reserves will be excluded.
- 6.5.3.2 Where more than one zone contributes to the wastewater reticulation to be designed, the wastewater discharge from each zone will be calculated using the individual zone area multiplied by the appropriate discharge per hectare as for the total catchment area (not the individual zone area).
- 6.5.3.3 The total catchment discharge is the sum of the individual zone discharges as calculated above.

Table 6-2 Wastewater Area/Zoning Coefficients

Sewage Discharge Coefficients (Litres Per Second Per Hectare)					
Residential Zone	Total Catchment Area (hectares)				
	0 to 2	Over 2 to 8	Over 8 to 80	Over 80 to 200	Over 200
Low Density	0.81	0.69	0.58	0.45	0.32
Normal/Standard Density	0.94	0.81	0.68	0.53	0.38
High Density	1.08	0.96	0.84	0.65	0.47

Note: The catchment area is defined as the total gravity catchment upstream of the point being considered.

6.5.4 Pipe Size for Gravity Sewer

- 6.5.4.1 The minimum permissible diameter for new wastewater reticulation aligned in the road reserve will be 150mm.
- 6.5.4.2 The minimum permissible diameter for all other new wastewater reticulation is 150mm except as detailed below.
- 6.5.4.3 When an Infill Subdivision, Development, or Cross Lease Subdivision (hereinafter referred to as Infill Development) occurs in an area served by an existing 100mm diameter wastewater drain, it will be upgraded to 150mm diameter to the lesser requirement as follows:
- From the point in the wastewater reticulation where there are a maximum of five residential units being served by the 100mm diameter wastewater drain downstream until the reticulation is at least 150mm diameter;
 - From the point of connection of the property being developed downstream until the reticulation is at least 150mm diameter;
 - Where 100mm diameter - wastewater reticulation is required to be upgraded to 150mm diameter or where it is proposed to lay 100mm diameter wastewater reticulation, an Engineering Drawing including the longitudinal section will be provided.
- 6.5.4.4 Where infill development results in the existing private drain becoming public wastewater reticulation, the existing pipe will be:
- Pressure and CCTV tested to prove that it is sound to the satisfaction of the Engineering Manager where it is 150mm or larger, or re-laid;
 - Surface opening access points will be required at every change in direction or change in grade. In general, the minimum access point will be a rodding point but inspection bends, mini-manholes or standard 1050mm diameter manholes may be required in appropriate circumstances.

6.5.5 Reuse of Existing Service Connections

- 6.5.5.1 A proposal to reuse an existing service will only be approved if the service is of adequate size and condition and one of the following conditions applies:

- a) It can be established that the service is less than 40 years old and Pressure and CCTV tested to prove that it is sound to the satisfaction of the Engineering Manager and has adequate surface opening access points along its length
- b) The service is to continue supplying the same building that it was originally intended for, and no others;

6.5.5.2 This policy applies only to the Council portion of the wastewater lateral ie. from the reticulation up to the Boundary inspection.

6.5.6 Disconnections

6.5.6.1 Redundant services will be disconnected from the Wastewater reticulation by Council's approved contractor at the main reticulation.

6.5.6.2 The service fitting lateral will be removed or plugged at the connection to the Wastewater reticulation. All cost associated with the disconnection will be recovered by Council from the landowner requiring the disconnection.

6.5.7 Grades and Velocities

6.5.7.1 All wastewater reticulation will be designed to utilise velocity and flow characteristics to improve hydraulic performance and minimise settlement of solids and future maintenance costs.

6.5.7.2 The same roughness factor will be adopted for all pipe materials to account for sewer slimes, grit deposits and other in situ variables such as construction performance and pipeline deterioration with age.

Table 6-3 Minimum Velocity and Grade Requirements

Internal Diameter	Residential Units Served	Minimum Grade	Minimum Velocity Flowing Full
150mm	1–5	1.25% - 1-in-80	1.0m/s
150mm	6–10	1.00% - 1-in-100	0.9m/s
150mm	11–19	0.80% - 1-in-125	0.8m/s
150mm	20–150	0.67% - 1-in-150	0.75m/s
>150mm	Specific design	Specific design	0.75m/s

Note:

Data presented in Table 6-3 approximates a pipe roughness equivalent to $k_s = 1.5\text{mm}$ for the "Colebrook White" formula or "rough concrete" for the Mears Water Flow Calculator.

6.5.7.3 Submission of catchment flow plans and calculations will be required on submission of the design plans for all reticulation serving more than 150 residential (or equivalent) units, or where the minimum grades and flows do not comply with Table 6-3.

6.5.8 Pipe Cover

6.5.8.1 Generally shallow wastewater reticulation, less than 1.2m in depth, will be avoided. Shallow wastewater reticulation limits the area which may be adequately serviced and limits the surcharge capacity in the case of blockage before overflow occurs.

6.5.8.2 Pipe systems will be designed to ensure the minimum cover over the barrel as set out in Table 6-4.

Table 6-4 Minimum Cover

Location of Drain	Minimum Cover for All Pipes
Areas subject to highway traffic loading eg. within road carriageway	750mm
Areas subject to light traffic loading outside road, eg ROWs, driveways, carparks and berms	600mm

6.5.8.3 Minimum cover may be reduced providing the reticulation is concrete encased for concrete pipes and concrete capped for PE/PVC and subject to the Councils' approval.

6.5.8.4 Where reticulation with inadequate cover requires concrete protection, this will be constructed in compliance with a specific design to the Engineering Manager's approval.

6.5.8.5 To avoid reflective cracking of pavements and differential settlement, concrete protection will not be permitted to penetrate the basecourse or pavement construction.

6.5.8.6 No concrete protection will be placed around the reticulation until the line has been inspected and approved by the Council. Reticulation testing will be undertaken after the concrete protection has been completed.

6.5.8.7 Reduced cover on reticulation may be approved without additional concrete protection providing the appropriate class of pipe is specified and cover is according to the pipe manufacturer's specification.

6.5.8.8 Wastewater reticulation will be no deeper than 2.5m below finished ground levels.

Good Practice

The following matters provide additional direction and guidance in the design of all pipe work that makes up the wastewater reticulation:

6.5.9 Gravity Pipe Material

6.5.9.1 Wastewater gravity sewers should be rubber ring jointed uPVC pipes and fittings complying with AS/NZS 1260 and laid in 6.0m lengths. Pipe stiffness should be in accordance with Table 6-5. (‘Sandwich Construction PVC pipes are not approved for use).

6.5.9.2 PE (polyethylene) pipe complying with AS/NZS 5065 may be used in specific circumstances (eg. for sleeving or relining existing wastewater gravity sewers) with the approval of the Engineering Manager. PE wastewater pipes will be black with white liner.

6.5.10 Calculation of Flow

6.5.10.1 In the majority of cases 150mm diameter reticulation wastewater reticulation may be provided without calculation provided that the Council can be satisfied that not more than 150 sections (or residential equivalent) will be served by this reticulation and that the reticulation is laid to the approved gradient as per Table 6-3.

6.5.10.2 The design flow comprises domestic wastewater, industrial wastewater and infiltration of stormwater.

Table 6-5 Pipe Stiffness Required for uPVC Pipe for Gravity Applications

uPVC Pipe	Public Wastewater Reticulation	Private Wastewater Drains
DN 100mm	SN 10	SN 6
DN 150mm	SN 8	SN 4
DN 175mm and larger	SN 8	SN 4
depths greater than 2.5m	Specific design to AS/NZS2566 design method	
wheel loads > 96 kN	Specific design to AS/NZS2566 design method	

6.5.11 Wastewater Area/Zoning Coefficients

6.5.11.1 In reference to Table 6-2 (Wastewater Area/Zoning Coefficients), the following matters apply:

- a) Several trunk gravity mains discharging into one pump station should be considered as separate catchments;
- b) Discharge rates from pump stations may be accumulated but their catchment areas should not be accumulated; and
- c) Industrial and commercial areas should be treated as Residential Normal Density unless a greater rate of discharge is known.

6.5.12 Grades and Velocities

6.5.12.1 Where velocity limits (Table 6-3) cannot be complied with, additional works may be required in order to obtain satisfactory operation of the system.

6.5.12.2 The recommended minimum grade for a 100mm wastewater sewer is 1-in-60, which allows for improved hydraulics and minimises future maintenance cost on the line. Flatter grades, not less than 1-in-120, may be permitted where steeper grades are not practical, and only with the written approval of the Engineering Manager.

6.5.13 Pipe Cover

6.5.13.1 Reticulation required at a depth greater than 2.5m (Table 6-5), will require the written approval of the Engineering Manager, and to the specific design criteria, approved by the pipe manufacturer.

6.6 Seismic Design and Liquefaction

This section outlines additional design consideration to address earthquake damage risk and liquefaction.

Mandatory Matters

Council requires the following standards to be met in reticulation design that addresses seismic and liquefaction risks:

6.6.1 General

- 6.6.1.1 All pipes and structures will be designed with adequate flexibility and provisions to minimise risk of damage during earthquakes.
- 6.6.1.2 Specially designed flexible joints will be provided at all junctions between pipes and rigid structures (such as reservoirs, pump stations, bridges, and buildings) in natural or made ground.
- 6.6.1.3 In liquefiable or lateral spread prone areas, a geotechnical investigation will be required. The geotechnical investigation will need to assess the potential of the ground to liquefy under seismic loading and assess the likely effects of liquefaction or lateral spread on buried infrastructure. The potential effect of large scale changes in grade and reduced levels of gravity

pipes, and structures, from seismic induced ground movement will be required. The assessment will be conducted in accordance with New Zealand Geotechnical Society guidance: Guideline for the identification, assessment and mitigation of liquefaction hazards.

Good Practice

The following matters provide additional direction and guidance in reticulation design that addresses seismic and liquefaction risks:

6.6.2 General

- 6.6.2.1 Historical experience in New Zealand earthquake events suggests that suitable pipe options, in seismically active areas, may include rubber ring joint PVC pipes, or PE pipes.
- 6.6.2.2 Piped infrastructure is not generally designed for a particular seismic event but rather for optimum resilience under seismic loading.

6.7 Access points

This section outlines standards for the design of manholes, rodding points and inspection points.

Mandatory Matters

Council requires the following standards to be met in the design and location of access points within the wastewater reticulation:

6.7.1 Concrete Manholes

- 6.7.1.1 Manholes will conform to SD601 to SD607 unless other detailed drawings are approved by Council.
- 6.7.1.2 Manholes must be designed to resist uplift especially in areas where high ground water is experienced.
- 6.7.1.3 Where there is a likelihood of groundwater accumulating around the manhole and where drainage of the wastewater trench, as per SD61e is unable to be provided, an approved prefabricated plastic manhole such as the Smart Pit™ will all be installed, see section 6.7.2.
- 6.7.1.4 Manholes are to be located in the road carriageway, preferably at the centreline of the road but no closer than 2.0m to kerb and channel, to minimise inflow from stormwater flowing down the road/street. Manholes maybe permitted on the grass berm or footpath provided that the fall is towards the road kerb and channel.
- 6.7.1.5 Manholes will be required in the following locations:
 - a) At least every 100m of pipe run (ie to ensure there is no greater than 100m of pipe length between manholes);
 - b) At change of pipe diameter grade and direction;
 - c) At junctions of main reticulation;
 - d) At least 2.0m away from adjacent kerb and channel; and

- e) Manholes are to be located clear of traffic lanes.

Note: For hillside situations, see also 6.7.3.

- 6.7.1.6 A uniform and continuous fall will be provided along the invert of the channels through the manhole of not less than 50mm between the invert of the inlet pipe and the invert of the outlet pipe.
- 6.7.1.7 The opening of a manhole (other than a mini-manhole) will have a minimum clear opening diameter of 600mm.
- 6.7.1.8 Access covers and frames for standard 1050 diameter manholes or larger will be heavy duty ductile iron manhole covers and frames with Class E strength classification to AS 3996 and complying with SD605 and SD606. Hinged lids will be aligned to close (if open) when driven over by a passing vehicle.
- 6.7.1.9 Manhole rungs or ladders will not be installed in manholes.
- 6.7.1.10 Shallow mini-manholes will be in accordance with the requirements set out on SD603 and SD604 or a proprietary PVC or polypropylene moulded product approved by Council.

6.7.2 Thermoplastic Manholes

- 6.7.2.1 The Council permits the use of thermoplastic manholes in place of concrete manholes subject to the following:
- The manholes must be designed, tested and approved to BS EN 13598-2 'Plastics piping systems for non-pressure underground drainage and sewerage. Plasticised poly (vinyl chloride) (PVC-U), polypropylene (PP) and polyethylene (PE). Specifications for manholes and inspection chambers in traffic areas and deep underground installations; and,
 - The manholes must be installed to the manufacturer's recommendations.

6.7.3 Rodding Points (Lamphole Cleaning Eyes)

- 6.7.3.1 Rodding points will be used in the following circumstances:
- Installed on straight pipe on straight grades;
 - At a maximum spacing of 50m;
 - At the head of a wastewater reticulation; and
 - At the top of steep banks where a standard manhole would be impractical.
- Note: buried preformed inspection bends maybe used in lieu of rodding points where a change in direction or grade is closer than 20m from a rodding point or manhole.
- 6.7.3.2 Vertical inspection pipework is to be 100mm diameter on a 100mm diameter rodding eye, on 150mm diameter and larger the vertical inspection pipework is to be 150mm diameter.
- 6.7.3.3 For details of rodding points see SD608, SD609 and SD610.
- 6.7.3.4 At the Engineering Manager's discretion one rodding point can be used before another manhole on hillside developments. This can be increased to two rodding points dependent on the grade of the pipelines.

6.7.4 Inspection 'T'

- 6.7.4.1 An Inspection 'T' as per SD611 will be installed on all private laterals within road reserve or as close as practical to the connection 'y' within private property. The inspection 'T' will be positioned 150mm from the road boundary.

Good Practice

The following matters provide additional direction and guidance in the design and location of access points within the wastewater reticulation:

6.7.5 Concrete Manholes

- 6.7.5.1 If manhole cover slabs other than "Humes" or "Hynds" pre-cast concrete cover slabs are to be used then the appropriate certification must be submitted to Council showing that the cover slabs will withstand loadings of 0.85HN (51kN).

6.8 Pumping Stations

This section outlines standards for the design of pumping stations but excludes Low Pressure pumping systems, see section 6.14.6).

Mandatory Matters

Council requires the following standards to be met in the use and design of wastewater pumping stations:

6.8.1 Pump Station Design

- 6.8.1.1 Pump stations will comply with Council's requirements and these specific designs are updated on a regular basis. Design will be dependent on a number of factors and should be discussed with the Council at an early stage.
- 6.8.1.2 Design of the pumping station will enable operation of the station in compliance with industry health and safety requirements having particular regard to safety from falling aspects on site.
- 6.8.1.3 Pumping stations will be of the wet-well type, fitted with approved types of submersible pumps that meet whole-of-life economies taking in capital cost, power consumption, likely parts and maintenance cost during design life.
- 6.8.1.4 Pumping stations will be located where occasional adverse effects of smell and/or noise will have minimum impact and not within 20m of an existing or potential residential dwelling.
- 6.8.1.5 Pump stations will not be located in low-lying areas with potential for surface flooding or Q100 flood inundation.
- 6.8.1.6 Sufficient duty pumping capacity will be available to handle the design flow rate from the catchment area that has been calculated for projected growth extending out to 25-years.
- 6.8.1.7 A minimum of two pumps on stainless steel guide rails with stainless steel lifting chains will be installed, with one acting as duty pump and the other on automatic standby. The duty sequence is to be alternate start on variable speed drives in accordance with Council's control system standards. The standby pump will be equal in capacity to the duty pump.

- 6.8.1.8 The wet well will be of sufficient volume and shape so as to limit the frequency of pump starts, allow cooling of pumps, minimise build-up of sludge and to minimise potential odours.
- 6.8.1.9 The dimensions of the wet-well will be such that under maximum flow conditions the number of starts for the pumps will not exceed the pump manufacturer's recommendations.
- 6.8.1.10 In Nelson City, a minimum of four hours on-site emergency storage, based on the design average dry weather flow volume measured above the overflow to storage, or high-level alarm level (measured by Multitrode or ultra-sonic level detector).
- 6.8.1.11 In the Tasman District, a minimum of ten hours on-site emergency storage is required, or six hours where approved by the Engineering Manager. This exception will consider environmental and cultural sensitivity. The storage design will be based on the design average dry weather flow volume measured above the overflow to storage, or high-level alarm level (measured by Multitrode or ultra-sonic level detector).
- 6.8.1.12 The storage facility will be self-draining and normally located in an underground approved structure within the site and covered with grassed topsoil or approved alternative top blending in with surroundings.
- 6.8.1.13 The storage structure will have a sealed access lid for inspections.
- 6.8.1.14 The wet well structures will be first priority for consideration of emergency storage volume by oversizing to minimise expensive underground structures and control features on site.
- 6.8.1.15 Wet wells will be provided with ventilation. An approved active fan assisted odour control system such as activated carbon odour control units will be constructed adjacent to the pump station to mitigate odours.
- 6.8.1.16 Ground floor levels will be at least 200mm above finished ground levels in order to exclude surface water entry.
- 6.8.1.17 All pump station site structures and the capacity of them will be designed for a minimum 50-year life complying with the building code. Note – these structures will need to comply with the Inundation Practice Note.
- 6.8.1.18 All pumping stations will be fitted with lids and internal safety frames. Outer safety frame supports need to be provided to allow for the removal of pumps.
- 6.8.1.19 All electrical systems need to be radio frequency neutral, isolated or complying with Central Government radio frequencies standards.
- 6.8.1.20 All storage chambers will be fitted with cleaning systems and pressure transducer level sensors connected to the telemetry network
- 6.8.1.21 All valve and emergency storage chambers will drain back to the wet well. The drains will be constructed with a water stop to prevent odour and hydrogen sulphate migration from the wet well and incoming reticulation.

6.8.2 Access and Services

- 6.8.2.1 A 25mm diameter water supply with a standard 20mm brass hose tap must be provided in the immediate vicinity of the pump station. This water source may be from the Council reticulation or a bore within the area where no Council reticulation exists.

- 6.8.2.2 This water supply will be fitted with an approved reduced pressure zone (RPZ) backflow preventer and - approved water meter/isolating valve assembly. A water meter is required.
- 6.8.2.3 Pumping stations and control buildings will be sited on a separate lot or a drainage or utility reserve. The lot is to be vested in Council and will have a sealed access road for maintenance vehicles. The site and buildings will comply with health and safety requirements and have appropriate lighting.
- 6.8.2.4 The site as a minimum must have screen planting on all common boundaries that will not exceed 2m in height on the South boundary.
- 6.8.2.5 The planting will not be within 1.5m of any chambers, cabinet, aerial or other structures associated with the facility.
- 6.8.2.6 The site must be fenced, encompassing the whole site, and there must be a lockable gate on the access.
- 6.8.2.7 The site must accommodate a means of lifting pumps and other heavy equipment, or alternatively access to enable mobile plant to perform. This task is to be provided on site without disruption to the public.
- 6.8.2.8 An approved flow meter will be installed on the outlet line from the pump station and connected to the telemetry system.

6.8.3 Electrical Equipment

- 6.8.3.1 An electrical pump control, alarm, and telemetry system is required on site. It will be assembled and installed in accordance with Council's standard specification.
- 6.8.3.2 An approved soundproof stainless-steel control cabinet is required to house electrical equipment. Cabinets are to be fitted with a lock keyed to Council's security system.
- 6.8.3.3 All electrical switch gear is to be located a minimum of 300mm above ground level. All electrical equipment is to be assembled and installed in accordance with these standards or the manufacturer's specifications.
- 6.8.3.4 All equipment including metering must comply with the requirements of the Network Utility operator and supplier (power).
- 6.8.3.5 Suitable alarm and system control interrogation and transmitting facilities will be provided to enable the pumping stations to be connected to Council's telemetry system.
- 6.8.3.6 Cable ducting from the pump station to the control cabinet must be sealed to protect against corrosive gasses travelling to the electrical switchboard.
- 6.8.3.7 Phase failure protection relays will be provided for all pump motors unless that protection is incorporated into the electronic control for Soft Start or Variable Speed Drive units.
- 6.8.3.8 Automatic control of the pump operation, together with a manual override facility is to be provided.
- 6.8.3.9 A standard three-phase industrial power connection will be supplied such that a portable generator can be connected when power failure occurs.

- 6.8.3.10 Suitable LED lighting will be provided for the pump station, cabinets and valve chambers with protective materials suited to the corrosive environment.
- 6.8.3.11 Details on pump/motor components and electrical control equipment will be incorporated into an Operation and Maintenance Instruction Manual.
- 6.8.3.12 The Manual will include as-built plans of the pump station including electrical wiring and operational schematic diagrams.
- 6.8.3.13 Electronic copies of the Manual will be supplied to Council on handover of the completed pump station and associated works.

6.8.4 Private Pumping Stations

- 6.8.4.1 Individual, private pump systems are permitted provided:
 - a) They meet the requirements of Appendix 1 (1.7 Services on Public Land) and the approved design;
 - b) Their construction meets the requirements of the NZ Building Code (a Building Consent will be required); and
 - c) The connection to the Council system is via an inspection chamber (This may require odour control) and a gravity pipe connection (pressurised pipelines must be located entirely on private property).
- 6.8.4.2 Private pumping stations must discharge to a chamber adjacent to the lot boundary. From this chamber, the effluent must gravitate in a 100mm (min) sewer lateral to the reticulation.

6.8.5 Wastewater Pressure Rising Mains

- 6.8.5.1 Wastewater rising mains will meet the requirements for the construction of water mains.
- 6.8.5.2 All pressure reticulation will be subject to specific design for cyclic dynamic stresses (fatigue), in selection of pipe pressure class. (Refer to Plastic Industry Pipe Association POP 101 and POP 010A and POP 010B). Refer also to materials selection in section 6.7.2.
- 6.8.5.3 The location of all pumping or pressure mains will be marked with an approved foil or wire banded tape, buried in the trench (see section 6.12).
- 6.8.5.4 All HDPE pumping mains must be coloured black with cream strip.

6.8.6 Commissioning

- 6.8.6.1 On completion of any pump station, and prior to handover to Council (residential only), a full commissioning test will be carried out on all components of the pump station. This commissioning will be in the presence of a representative of Council and of Council's operations and maintenance contractor.
- 6.8.6.2 It should be noted that Council requires, prior to the 224 certificate being issued, that Council has a full set of as-builts and a complete Operations and Maintenance manual for the operation of the development. This is to ensure that the Council maintenance contractor can operate the appropriate plant correctly. Operations and Maintenance manuals will be provided to Council in electronic format.

Good Practice

The following matters provide additional direction and guidance in the use and design of wastewater pumping stations that will be vested in Council ownership:

6.8.7 General

- 6.8.7.1 New pumping stations will only be accepted by Council when all other practical options have been ruled out (filling of sites is a normal practical option to gain the required gravity fall so that pump station sites can be avoided).
- 6.8.7.2 Other odour control devices may be approved on a case-by-case basis to be approved by Council.

6.9 Reticulation Construction and Installation

6.9.1 Trenching

This section sets out Council requirements for the construction and installation of wastewater reticulation.

Mandatory Matters

Council requires the following standards to be met in the construction and installation of wastewater reticulation using excavated trenches:

6.9.2 Trench Width

- 6.9.2.1 The minimum trench width will be 200mm wider than the external diameter of the collar of the pipe being laid.
- 6.9.2.2 The trench will be of sufficient width to permit with freedom the installation of all trench support and to allow the laying and jointing of pipes and placing of bedding and pipe surround materials.

6.9.3 Base of Excavation

- 6.9.3.1 No construction or work upon the excavation bottom will commence until the natural bottom of the excavation has been inspected and accepted by the DPA.
- 6.9.3.2 The foundation of the trench is to be checked for stability of the soil by the DPA.
- 6.9.3.3 In respect of trench floor bedding, the DPA will order the use of additional granular bedding material as specified in AS/NZS 3725 for concrete pipes, or AS/NZS 2566 for PVC and other flexible pipe systems.

6.9.4 Trench Support

- 6.9.4.1 The contractor will provide trench support to comply with the requirements of relevant New Zealand legislation.
- 6.9.4.2 The contractor will ensure that the sides of the trench are sufficiently supported so that cracking of the surrounding ground does not occur.

6.9.4.3 The contractor will comply with health and safety legislation.

6.9.5 Dewatering

6.9.5.1 Excavations will be kept free of water during construction.

6.9.5.2 In no circumstances will stormwater or ground water be allowed to drain into any existing wastewater reticulation and pipe ends will be plugged to prevent such ingress.

6.9.5.3 Discharge of stormwater or groundwater to existing stormwater drains or the pipes already laid will be permitted providing adequate silt traps prevent debris and suspended matter from entering drains.

6.9.5.4 Should deposits in existing stormwater drains or the pipes already laid occur as a result of the operations of the Developer or the contractor, such deposits will be cleared forthwith at the Developer's or the contractor's cost as the case may be.

6.9.5.5 The contractor or Developer will cause as little damage or interference to property or persons as possible in disposing of water from the works, and will be responsible for any damage or interference, which may be caused. This will include any damage to the structure of any road.

6.9.6 Metal Bedding

6.9.6.1 Metal bedding will be in accordance with SD614 and SD615. This includes bedding, haunch support and side support material as defined by NZS 2566 and AS/NZS 3725.

6.9.6.2 For concrete pipes, "Type H2" bedding in accordance with AS/NZS 3725 will be used.

6.9.6.3 The bedding material will be:

- a) In a sand environment – Saturated sand;
- b) For PVC and flexible pipes - NZTA M4 AP20, or as per AS/NZS 2566, Appendix G; and,
- c) For concrete pipes - NZTA M4 AP20, or as per AS/NZS 3725, Table 6.

6.9.6.4 Bedding compaction will be undertaken in accordance with AS/NZS 3725 for type H2 support.

6.9.6.5 The pipes will be laid and brought to true alignment and level before installing the metal haunching, side support and covering the pipes.

6.9.7 Pipe Embedment

6.9.7.1 The metal haunching and side support will be placed uniformly along and around the whole length of the pipe barrel, couplings and other appurtenances in a manner to ensure uniform density of side support (including haunch support) and overlay with no distortion, dislodgement or damage to the pipeline.

6.9.7.2 Following placement, the embedment material will be compacted in layers to uniformly support the pipe.

6.9.7.3 When choosing compaction equipment, the number of passes and the thickness of layer to be compacted, the material to be compacted and the pipe to be installed will be taken into account.

- 6.9.7.4 Compaction equipment or methods that produce horizontal or vertical earth pressures that may cause damage to, or excessive distortion of, the pipe will not be employed.
- 6.9.7.5 Metal haunching and side support will be compacted to the manufacturer's requirements and as a guide, a minimum Clegg Impact Value of 25 shall be achieved at any point on any haunching constructed of AP20 NZTA M4.

6.9.8 Installation of Geotextiles

- 6.9.8.1 Where there is a possibility of migration of fines between the native soil and the pipe surround soil, the DPA will require the metals to be protected by an approved geotextile filter fabric that overlaps by at least 300mm. The extent of this "geotextile wrapping" must be shown on the As-built plans.

6.9.9 Water-stops and Trench Groundwater

- 6.9.9.1 A specific design is needed where permeable bedding is used. Water-stops and trench drainage will be constructed to prevent unwanted movement of groundwater along the trench and pipe bedding, see SD613. All captured stormwater must be reticulated to the stormwater network, or at least an approved stormwater outlet.
- 6.9.9.2 Manholes will be considered to be water-stops provided they are constructed appropriately.
- 6.9.9.3 Where water stops are required, they must be provided at the intervals set out Table 6-6.

Table 6-6 Water Stop Spacings

Grade	Spacing
1 in 15 or steeper	12m
1 in 15	15m
1 in 25	30m
1 in 100	60m

- 6.9.9.4 Where necessary and practicable, trench drainage as per SD613 will be required to prevent groundwater infiltration at manhole connections.

Note: This will not be necessary where prefabricated plastic manholes such as the Smart Pit™ are used (see sections 6.7.2 and 6.11.2).

6.9.10 Pipe Installation

- 6.9.10.1 To help with future identification the end caps and inside of the end of all new wastewater laterals must be painted with red acrylic paint and marked with a 75mm x 25mm ground treated marker stake suitably identified and partly painted red. (Note: stormwater laterals are to be marked green).
- 6.9.10.2 A laser will be used by the contractor for fixing line and grade, for setting the pipes to line and level, and for jointing on all major pipe-laying work where possible.
- 6.9.10.3 The maximum deviation in level of pipe invert when laid will be 5mm from design level. The line must have a continual falling grade such that water cannot pond in any part of the pipeline.

- 6.9.10.4 The maximum horizontal deviation from a straight line will be 10mm.
- 6.9.10.5 Pipes will not be laid on bricks, blocks and wedges or other temporary or permanent supports except when concrete surround is to be placed.
- 6.9.10.6 Joints will be flexible and watertight.
- 6.9.10.7 Pipes will be kept clear of dirt or debris, and any pipes that contain such matter will be required to be cleaned out. Internal pipe walls will be kept clean and free of all dirt, rubbish and water. Spigots, sockets, rubber rings, etc, will be thoroughly cleaned before jointing.
- 6.9.10.8 No glue joints will be permitted.
- 6.9.10.9 No new reticulation is to be connected to Council's existing operational reticulation unless the new reticulation has been checked and is free of all debris materials.

Good Practice

The following matters provide additional direction and guidance in the construction and installation of wastewater reticulation using excavated trenches:

6.9.11 General

- 6.9.11.1 Generally, a plate compactor is to be run over the trench base to bind the surface and identify any obvious weak spots.
- 6.9.11.2 Where the bottom of an excavation is unable to provide a firm foundation with minimum bearing capacity of 50kPa (eg. clay soils that can easily be penetrated 40mm with a thumb or in sand or gravel that makes a footprint more than 10mm deep) at the required level without abrupt irregularities, engineering advice should be sought on how to provide a satisfactory foundation (see AS/NZS 2032:2006, clause 5.3.6).
- 6.9.11.3 Where trench support extends below the invert of the pipeline or structure, special precautions may be required including leaving part of the support in place, to ensure the foundation of the pipe or structure is not weakened.
- 6.9.11.4 Groundwater lowering may be permitted except where this practice may present a risk of subsidence. Resource consent may be required.
- 6.9.11.5 Concrete surround for concrete pipes.
- 6.9.11.6 For concrete pipes, the DPA may provide concrete surround following the written approval of the Engineering Manager, and to the following specifications:
- In areas subject to vehicle traffic where the cover of the pipe barrel is, or will be, less than that required for the class of pipe as specified by the pipe manufacturer; and
 - In areas other than those covered above, where the cover over the barrel of the pipe is or will be less than 300mm, irrespective of the type or class of pipe.
 - Flotation of the pipe during placement of concrete surround will be prevented. PVC pipes will not be concrete surrounded.

6.9.12 Water-stops and trench groundwater

- 6.9.12.1 Manholes can be considered to be water-stops provided they are constructed appropriately.
- 6.9.12.2 Where water stops are required, they should be provided at the intervals set out in Table 6-6.

6.10 Trenchless Technology

This section relates to the use of trenchless technology for the installation of wastewater reticulation.

Mandatory Matters

Council requires the following standards to be met in the use of trenchless technology for the installation of wastewater reticulation:

6.10.1 General

- 6.10.1.1 Trenchless technology will only be used in specific circumstances where approved by the Engineering Manager.
- 6.10.1.2 Pipes used for trenchless installation will have suitable mechanically restrained joints, specifically designed for trenchless application, which may include integral restraint, seal systems, or heat fusion welded joints.
- 6.10.1.3 Any trenchless technology and installation methodology will be chosen to be compatible with achieving the required gravity pipe gradient – refer to the manufacturer's and installer's recommendations.
- 6.10.1.4 The following details including location of access pits and exit points will be submitted to the Engineering Manager for approval:
- a) Clearances from services and obstructions; the depth at which the pipeline is to be laid to ensure minimum cover is maintained;
 - b) The pipe support and ground compaction;
 - c) How pipes will be protected from damage during construction;
 - d) Any assessed risk to abutting surface and underground structures; and
 - e) A clear methodology of how to deal with unknown obstructions and services.
- 6.10.1.5 Gouging or notching of the pipe will not exceed 10% of the pipe wall thickness for pressure pipe and 20% of the pipe wall thickness for gravity pipe. Pipe will not be bent to a radius less than 35 times the pipe OD for PE pipes or 600 times the pipe OD for PVC pipes.
- 6.10.1.6 The specified allowable load on the pipe will not be exceeded during pulling.
- 6.10.1.7 Where gouging or notching exceeds the above limits or if buckling of the pipe occurs, that length of pipe will be removed, and a new section welded in at the nearest join.
- 6.10.1.8 The contractor will over tow the pipe by one lineal metre for each length of pulled pipe that is the greater of one manhole length or 200m. The excess pipe length will be supplied to the DPA for a visual inspection.

Good Practice

The following matters provide additional direction and guidance in the use of trenchless technology for the installation of wastewater reticulation:

6.10.2 General

6.10.2.1 Trenchless technology may be preferable for alignments passing through or under:

- a) Environmentally sensitive areas;
- b) Built-up or congested areas to minimise disruption and reinstatement; Major road crossings;
- c) Significant vegetation;
- d) Vehicle crossings and areas with high quality paving surface;
- e) Where there is a large number of existing services (thorough investigation is required to verify the position of existing services).

6.10.2.2 For new pipes, trenchless installation methods may include:

- a) Horizontal directional drilling (HDD) (PVC with restraint joint/fusion welded PE);
- b) Uncased auger boring/pilot bore micro tunnelling/guided boring (PVC with restraint joint/fusion welded PE);
- c) Static pipe bursting (GRP/vitrified clay (VC)/reinforced concrete) (PVC with restraint joint/fusion welded PE).

6.10.2.3 For pipe rehabilitation/renovation, trenchless installation methods may include:

- a) Slip lining/grouting (PVC with restraint joint/fusion welded PE);
- b) Close fit slip lining (PVC with restraint joint/fusion welded PE);
- c) Static pipe bursting (PVC with restraint joint/fusion welded PE);
- d) Reaming/pipe eating/inline removal (PVC with restraint joint/fusion welded PE);
- e) Soil displacement/impact moleing (fusion welded PE);
- f) Cured in place pipe (thermoset resin with fabric tube).

6.10.2.4 Further information on trenchless technologies may be found in 'Trenchless technology for installation of cables and pipelines' (Stein), 'Trenchless technology – Pipeline and utility design, construction and renewal' (Najafi), and 'Guidelines for horizontal directional drilling, pipe bursting, micro-tunnelling and pipe jacking' (Australasian Society for Trenchless Technology).

6.11 Manhole Construction

The following standards relate to the installation of manholes.

Mandatory Matters

Council requires the following standards to be met in the installation of manholes:

6.11.1 Concrete Manholes

- 6.11.1.1 Manholes will be constructed in accordance with SD601 to SD607.
- 6.11.1.2 All concrete manholes will be made water tight by effective sealing of manhole section joints with mastic sealant and around pipe entries, where applicable, using epoxy mortar inside and out.
- 6.11.1.3 The connection of PVC pipes to concrete structures, such as manholes and sumps, will be with a purpose made PVC starter and finisher with a 'gritted' external surface.
- 6.11.1.4 The connection of PE pipes to concrete structures will be in accordance with SD607.
- 6.11.1.5 All PVC pipes entering or leaving a manhole will have one flexible joint within 200mm of the manhole.
- 6.11.1.6 All concrete pipes entering or leaving a manhole will have one flexible joint within 500mm of the manhole.
- 6.11.1.7 The channel through the manhole will be formed from in-situ concrete properly formed to grade and radius sweeps. The channel will be finished with a smooth, regular half circle invert with falls as specified in SD601 and SD603. Benching will be steel float finished to give a regular smooth surface.

6.11.2 Installation of Thermoplastic Manholes

- 6.11.2.1 In regard to thermoplastic manholes, installation will be to the supplier's requirements subject to the following conditions:
 - a) The ground is firm and stable;
 - b) The pipe size is small (ie. pipes up to and including diameter NB 225mm).
- 6.11.2.2 A manhole from thermoplastics will consist of a factory manufactured benched base, a vertical riser(s), a suitable transition, as necessary, from the base to the riser (eg. an adaptor), a cover slab, a throat, as necessary, from the cover slab to the lid at ground level, a frame and a cover. The components must be easy to assemble on site to form a watertight construction.
- 6.11.2.3 Manholes from thermoplastics will have a safety factor of at least two against flotation after backfilling (eg. weight of backfill over horizontal ring fins and cover slab).
- 6.11.2.4 All components of the manhole will be designed by the manufacturer for the expected site loading including vehicle loads of 51kN (0.85HN) where in trafficable areas. A manufacturer's certificate will be provided to this effect.
- 6.11.2.5 Depth to the invert of the outlet from the lid will not exceed 3.0m.

6.12 Tracer Tape

The following standards relate to the use and installation of tracer tape for pumping mains and gravity pressure mains.

Mandatory Matters

Council requires the following standards to be met in the installation of tracer tape:

6.12.1 Tape Location, Tape Type and Tape Installation

- 6.12.1.1 The location of all pumping mains and gravity pressure mains (swallows) will be marked with a foil tape buried in the trench.
- 6.12.1.2 The tape will be red, 50mm wide, and printed with “CAUTION PRESSURE SEWER MAIN BURIED BELOW” or similar message. All printing will be encased to avoid any rub-off.
- 6.12.1.3 The tape will be either a woven reinforced acid and alkali resistant polythene plastic with a solid aluminium foil core which will be visible from both sides.
- 6.12.1.4 The tape will be buried above the centre line of the pipe within 300mm to 400mm from the finished surface, refer SD702.
- 6.12.1.5 All joints in the tape (eg. roll ends, accidental breaks and at tees) will be made electrically conductive with purpose made splice clips installed to the specific manufacturer's instructions. Tying together of the tape ends is not acceptable as the polythene coating will prevent electrical conductivity.
- 6.12.1.6 The tape will be brought up inside the surface box risers at all manholes and air valves with a 300mm long tail so that pipe location equipment can be readily connected.

6.12.2 Tracer Wire

- 6.12.2.1 When a pumping main or swallow pipe is installed by a directional drilling technique or bored through the ground for a distance exceeding 20 metres a specific design for traceability is required.

6.12.3 Testing

- 6.12.3.1 The tracer tape or wire will be tested by the contractor for continuity using an electric pulse induction system. The test must be witnessed and approved by Council. The new pipeline will be tested between manholes, valves, etc where the tape is brought up inside the surface box risers. The test will only be undertaken when all work associated with laying the wastewater main is complete.

6.13 Valve painting

Valves will be painted as shown on SD616.

Good Practice

The following matters provide additional direction and guidance in the installation of tracer tape:

6.13.1 General

6.13.1.1 “Thor Tec™” tape is an acceptable product.

6.13.1.2 Alternatively, acceptable tape will be a durable sinusoidal stainless-steel wire encased in a polythene strip. “Waterwave” and “Wavelay” are acceptable products.

6.14 Testing

This section relates to the testing of wastewater reticulation.

Mandatory Matters

6.14.1 General

Council requires the following standards to be met in testing of wastewater reticulation prior to connection:

6.14.1.1 Connection to existing wastewater mains will not be made until all upstream work has been completed and inspected and approved by Council.

6.14.1.2 Specifically, this will include flushing and testing of all new pipework, manholes, and other wastewater facilities by the contractor and internal (CCTV) and external inspections by Council.

6.14.1.3 No contractor is permitted to access a live wastewater system without the written approval of the Engineering Manager.

6.14.1.4 Only Council’s approved maintenance contractor is permitted to undertake connections to Councils reticulation.

6.14.2 Air or Pressure Testing (for Non-Pressure Pipelines)

6.14.2.1 All non-pressure pipelines to be vested in Council ownership will pass one of the following air or water pressure tests:

Air Test – To NZS 4404:2010 Appendix C, C2. 1 ‘Low pressure air test’. For safety reasons, plugs must be well braced into position as the failure of a plug could result in serious injury.

6.14.3 Hydrostatic Test – NZS 4404:2010, Appendix C, C2. 2 ‘Hydrostatic test’

6.14.3.1 All manholes will be watertight and may require testing at the Council’s direction. The test involves plugging and filling the manhole with water (including time allowed for absorption for concrete manholes). During the test, the level of water in the manhole will not drop more than 5 mm in 10 minutes for concrete manholes. For thermoplastic manholes, the allowable make up water will be 0.5 litres/hour per metre length per metre diameter.

6.14.4 Pressure Pipelines

6.14.4.1 All pressure pipelines to be vested in Council ownership will pass the hydrostatic pressure test in NZS 4404:2010 Appendix C, C3 'Pressure pipelines – Field hydrostatic pressure testing'.

6.14.5 Closed-circuit Television Inspection (CCTV)

6.14.5.1 All pipelines to be vested in Council ownership will pass a closed-circuit television (CCTV) inspection, carried out at an appropriate time agreed by Council or at the completion of the works.

6.14.5.2 A professional operator with proof of experience in operating such devices will carry out the CCTV inspection using a pan and tilt camera, in accordance with the technical specifications of the NZ Pipe Inspection Manual (published by the New Zealand Water & Wastes Association).

6.14.5.3 The operator will 'pan-around' every joint and check every lateral connection and defect.

6.14.5.4 The video footage in DVD format, and the accompanying CCTV log sheets in electronic format for each wastewater sewer length (as per the template in the NZ Pipe Inspection Manual), showing the features and condition of all inspected manhole lengths, will be provided to Council. Video footage supplied without log sheets will not be accepted.

6.14.5.5 All pipelines will be free of debris and flushed within 24-hours prior to inspection.

6.14.5.6 Inspections of non-cleaned pipelines are not acceptable.

6.14.5.7 A pipeline will fail its inspection if:

- a) The pipe is horizontally misaligned or deformed by more than 5% of the pipe diameter;
- b) The pipe has visible dips or ponding of water;
- c) The pipe has visible defects, such as open or displaced joints, defective or protruding laterals, cracked barrels or similar defects;
- d) There is evidence of infiltration at joints or laterals.

6.14.6 Low Pressure Sewerage Pumping Systems

6.14.6.1 Pressure sewerage systems will be designed by a competent designer. Pressure pumping systems will meet Council's requirements. Note – in Nelson City area, specific approval from Nelson City Council will be required for this type of system

6.14.6.2 Designer and Pump Supplier to provide a PS2 and PS4 design approval on completion of installation.

6.14.6.3 The design of low pressure sewerage pumping stations (in Tasman District Council) will be guided by the Tasman District Council's Owner and Occupier's Manual and Council's installation instructions.

6.14.7 Low Pressure Pump Station Non-Residential Zoning (Industrial and Commercial)

6.14.7.1 At time of subdivision, the Developer is required to install all wastewater reticulation and an approved boundary kit (point of connection) for all proposed lots. The boundary kit is the demarcation point of the public reticulation.

- 6.14.7.2 The property owner is required to install an approved low-pressure pump station at the time of building consent. The pump station is required to be sized according to proposed building use.
- 6.14.7.3 The pumping station and the electrical operations box is to be installed in a location appropriate in relation to the building. The pumping station to be installed at a level approximately 100mm below the floor level of the building.
- 6.14.7.4 The property owner is responsible for providing power to this pump station.
- 6.14.7.5 The property owner is responsible for providing and maintaining all plumbing to the boundary kit (point of connection) and the operation of the pumping station.
- 6.14.7.6 The use and the operations of the pumping station shall follow Council “Owner and Occupier’s Manual”.

6.14.8 Testing – General

- 6.14.8.1 All gravity pipelines to be vested in Council ownership may be required to be tested for short term vertical deflection using an appropriate proving tool (“rigid prover”) and complying with AS/NZS 2566, Table 5.6, Section 6 and Appendix O – “Diametric Deflection Measurement”.
- 6.14.8.2 Other testing as considered appropriate may be required by Council to ensure Council’s future infrastructure will meet its projected life cycle. This will be discussed at the preconstruction meeting if new testing technology has become available since the approval of this document.

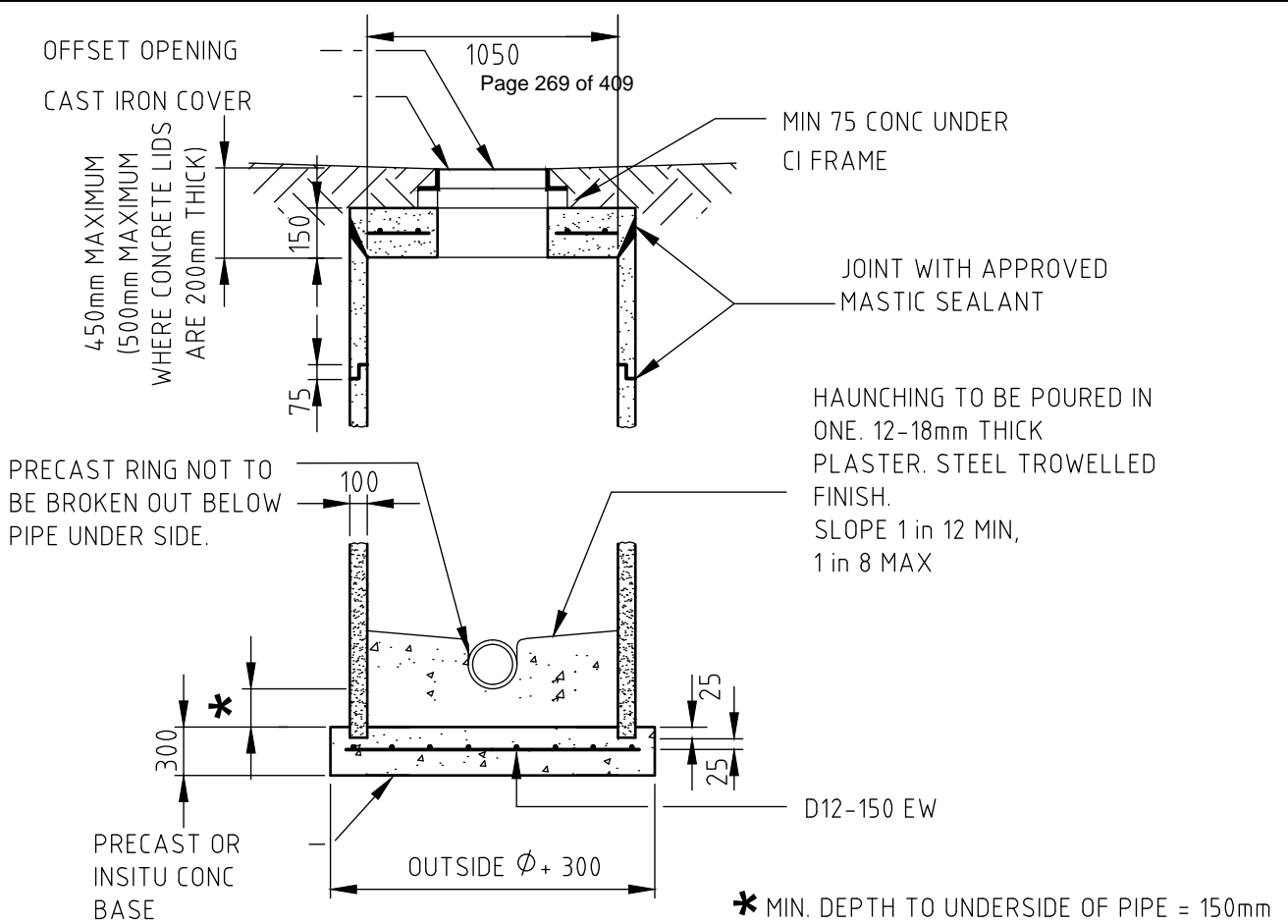

PRECAST MANHOLE DETAIL

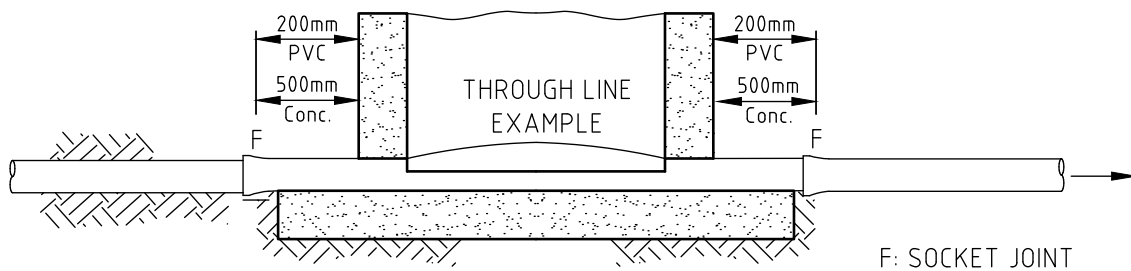

FLEXIBLE JOINTS AT MANHOLES

NOTES

1. ALL "INSITU" CONCRETE TO BE VIBRATED
2. CONCRETE CRUSHING STRENGTH TO BE 27.5 MPa AFTER 28 DAYS
3. MAX. SIZE OF PIPE TO BE 450 mm DIA FOR 1050mm MANHOLE
4. PRECAST CONCRETE MANHOLE RISERS SHALL COMPLY WITH THE REQUIREMENTS FOR CLASS 2 PRECAST CONCRETE PIPES TO AS/NZS 4058, 2007
MAXIMUM GRADIENT FOR HAUNCHING THROUGH MANHOLES SHALL BE 1 in 3
5. HYDROPHILLIC SEALANT SHALL BE USED WHERE THERE IS A HIGH GROUNDWATER LEVEL OR WHERE DRAINAGE OF THE TRENCH IS NOT POSSIBLE. THIS SHALL BE USED FOR ALL WASTEWATER MANHOLES, AS PER DRAWING 607 (UNLESS APPROVED OTHERWISE BY COUNCIL).
6. SEALANT TO BE ADEKA ULTRASEAL P-201, (or similar) WATER SWELLING ELASTIC SEALANT 10mm MIN. THICKNESS AROUND THE PIPE AT PUDDLE FLANGE CURED BEFORE PLACING EPOXY MORTAR IN LINEAR JOINT. MIN. COVER TO SEALANT FROM FREE EDGE OF INSITU CONCRETE IS 75mm

NELSON CITY COUNCIL

GROUP MANAGER INFRASTRUCTURE, NELSON

1050 ϕ PRECAST MANHOLE FOR PIPELINES
UP TO AND INCLUDING 450 ϕ (1 OF 2)

TASMAN DISTRICT COUNCIL

ENGINEERING SERVICES MANAGER, TASMAN

DATE

01/07/19

NELSON - TASMAN
LAND DEVELOPMENT MANUAL

601

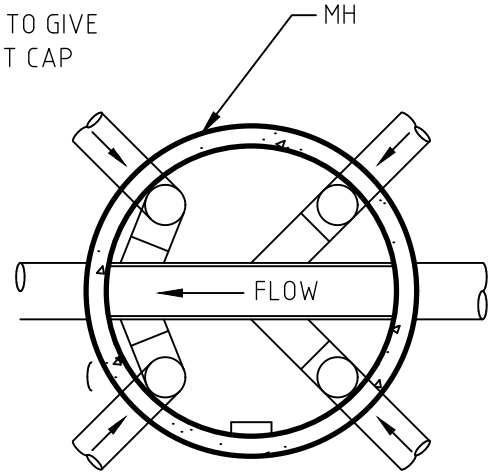
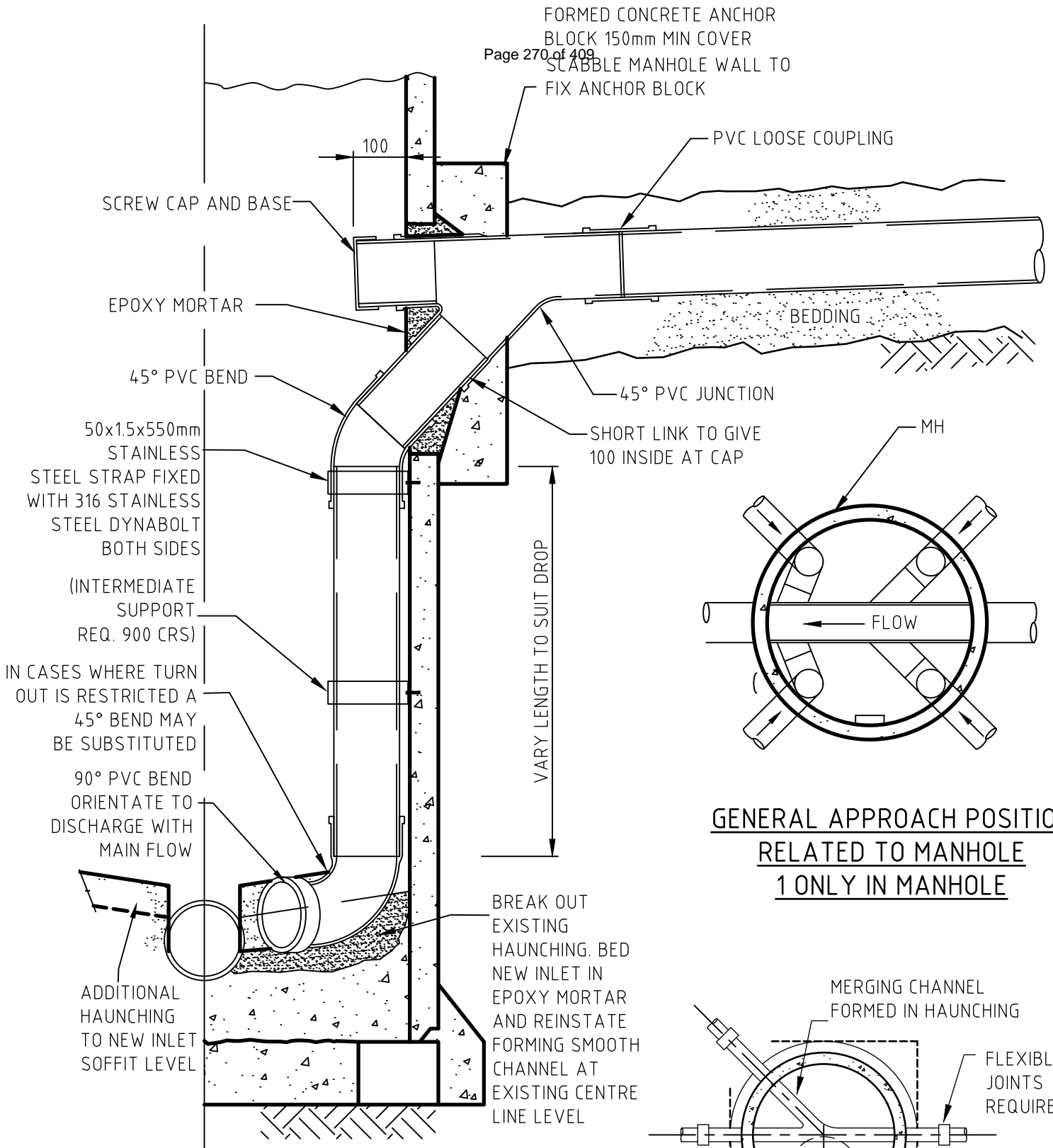

**GENERAL APPROACH POSITION
RELATED TO MANHOLE
1 ONLY IN MANHOLE**

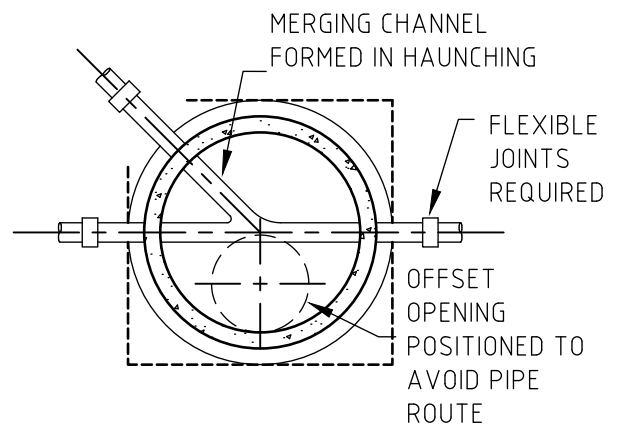

TYPICAL PLAN

**INTERNAL DROP MANHOLE
DETAIL PVC 150 φ**

TO BE USED IN SPECIAL CASES AT ENGINEERS
DIRECTION FOR EXISTING MANHOLES ONLY

<p>NELSON CITY COUNCIL <i>[Signature]</i> GROUP MANAGER INFRASTRUCTURE, NELSON</p>	<p>1050ø PRECAST MANHOLE FOR PIPELINES UP TO AND INCLUDING 450ø (2 OF 2)</p>		
<p>TASMAN DISTRICT COUNCIL <i>[Signature]</i> ENGINEERING SERVICES MANAGER, TASMAN</p>	<p>DATE 01/07/19</p>	<p>NELSON - TASMAN LAND DEVELOPMENT MANUAL</p>	<p>602</p>

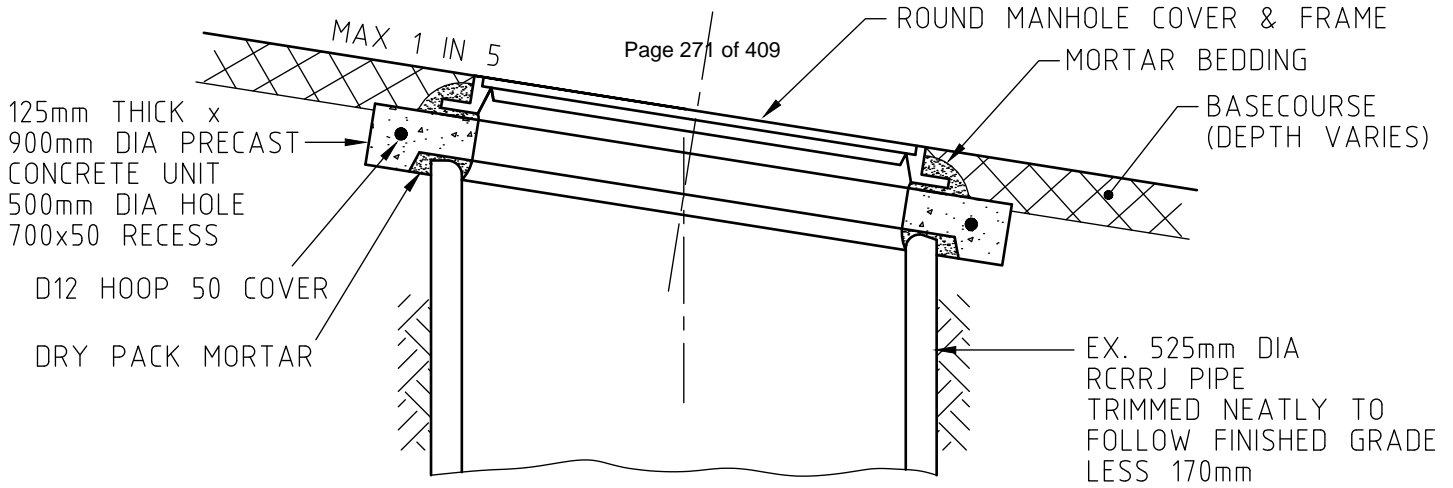

TOP FOR DRIVEWAYS OR R.O.W.

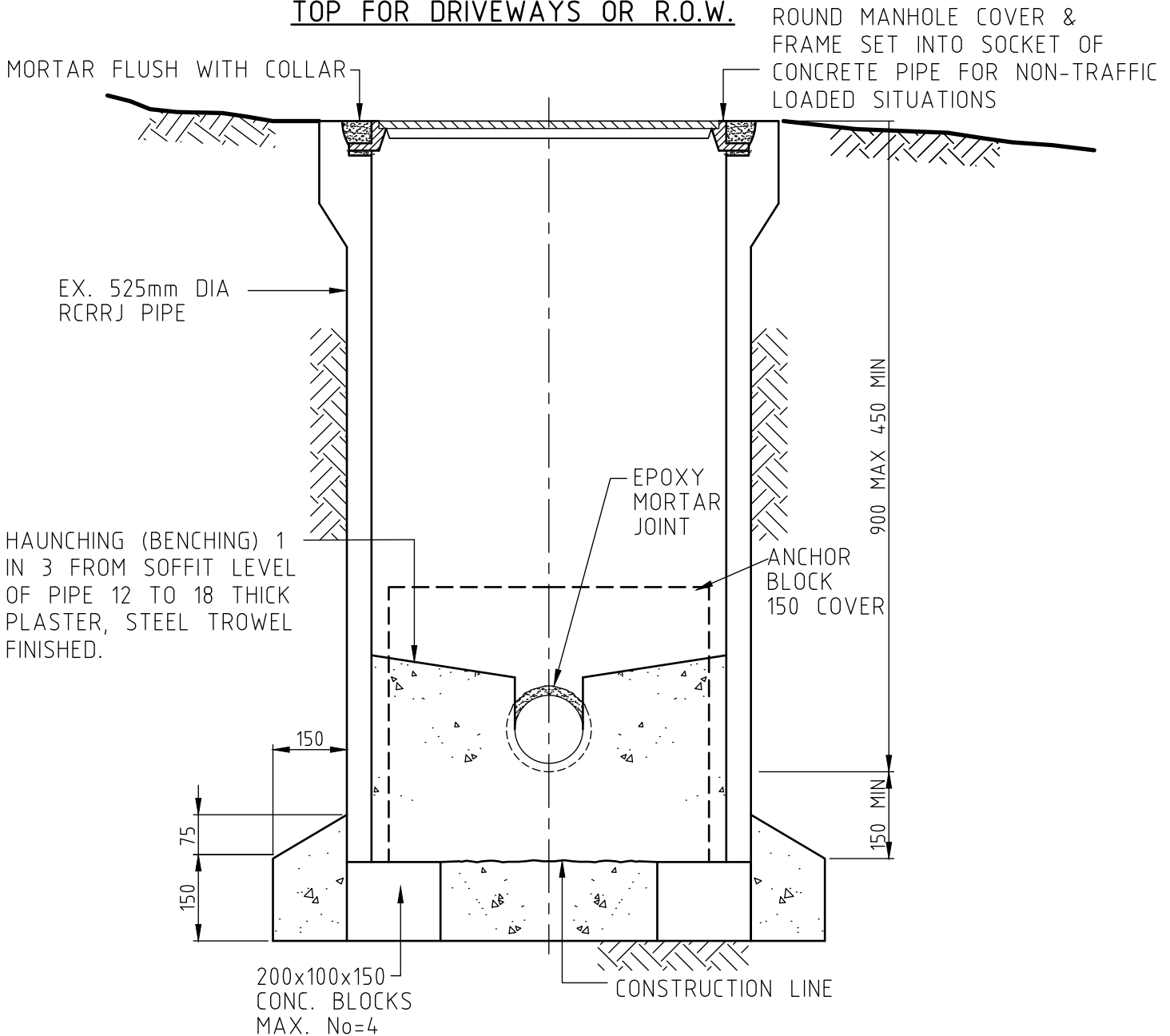

CAST INSITU BASE

NELSON CITY COUNCIL
[Signature]
GROUP MANAGER INFRASTRUCTURE, NELSON

SHALLOW MINI - MANHOLE
(1 OF 2)

TASMAN DISTRICT COUNCIL
[Signature]
ENGINEERING SERVICES MANAGER, TASMAN

DATE
01/07/19

NELSON - TASMAN
LAND DEVELOPMENT MANUAL

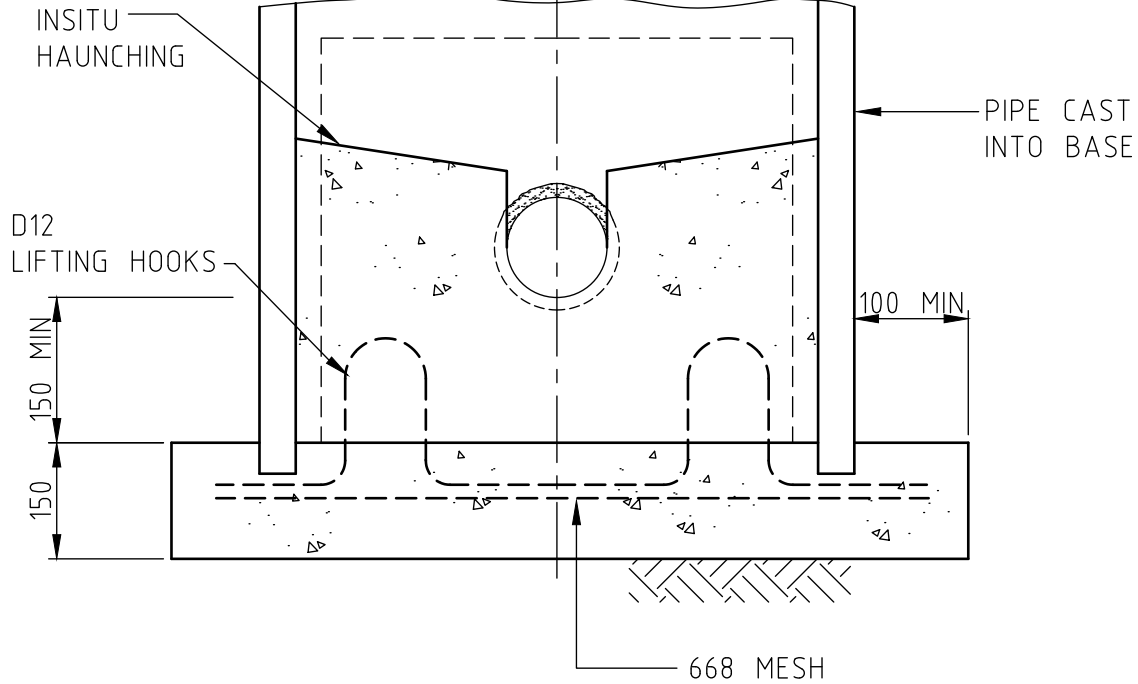

603



ALTERNATIVE PRECAST UNIT

NOTES

1. APPROVED PRE-FORMED PLASTIC INSPECTION CHAMBERS MAY BE USED AS MINI-MANHOLES FOR PIPE SIZES 100mm ϕ & 150mm ϕ SUITABLE FOR SEWER & STORMWATER SEWERS
2. MINI-MANHOLES ARE NOT TO BE ASSUMED TO REPLACE THE STANDARD MANHOLE
3. MINI-MANHOLES SHALL NOT BE USED IN AREAS SUBJECT TO VEHICULAR TRAFFIC, EXCEPT IN FORMED RESIDENTIAL DRIVEWAYS OR RIGHTS OF WAYS FOR LIGHT DOMESTIC VEHICLES
4. THE USE OF MINI-MANHOLES IS TO BE LIMITED, AND AT THE DISCRETION OF COUNCIL:
 - A) MANHOLES LESS THAN 1M DEEP
 - B) THE MAXIMUM PIPE SIZES OF 150mm ϕ FOR SEWERS & 225mm ϕ FOR STORMWATER DRAINS
 - C) MANHOLES AT THE HEAD OF A LINE
 - D) STRAIGHT THROUGH MANHOLES
 - E) CHANGES OF GRADE
5. CONCRETE MINI-MANHOLES AS DETAILED ARE NOT TO BE USED IN SEWERS AT:
 - A) JUNCTIONS
 - B) DEFLECTIONS GREATER THAN 45 DEGREES.
6. COVER & FRAME SHALL BE CAST IRON or DUCTILE IRON TO CLASS C STRENGTH TO AS3996 (CLASS & STANDARD TO BE STAMPED OF FRAME & LID)
7. COVER MUST HAVE 2 SEPARATE RECESSED SLOTS TO FACILITATE LIFTING & REMOVAL OF COVER, AND MUST BE WATER TIGHT TO PREVENT SW INGRESS
8. COVERS MUST HAVE ANTI-SKID PATTERN EMBOSSED ON TOP WITH THE WORDS WASTEWATER or STORMWATER. ALL FONT TO BE GOTHIC, 15mm HEIGHT RAISED 2.5mm
9. ANY OTHER WORDING, SUCH AS THE SUPPLIERS & MANUFACTURERS NAME, SHALL BE PLACED ON THE UNDERSIDE OF THE COVER (NOT ON THE TOP)

<p>NELSON CITY COUNCIL</p>  <p>GROUP MANAGER INFRASTRUCTURE, NELSON</p>	<p>SHALLOW MINI - MANHOLE</p> <p>(2 OF 2)</p>		
<p>TASMAN DISTRICT COUNCIL</p>  <p>ENGINEERING SERVICES MANAGER, TASMAN</p>	<p>DATE</p> <p>01/07/19</p>	<p>NELSON - TASMAN</p> <p>LAND DEVELOPMENT MANUAL</p>	<p>604</p>

NOTE:
STORMWATER
or WASTEWATER

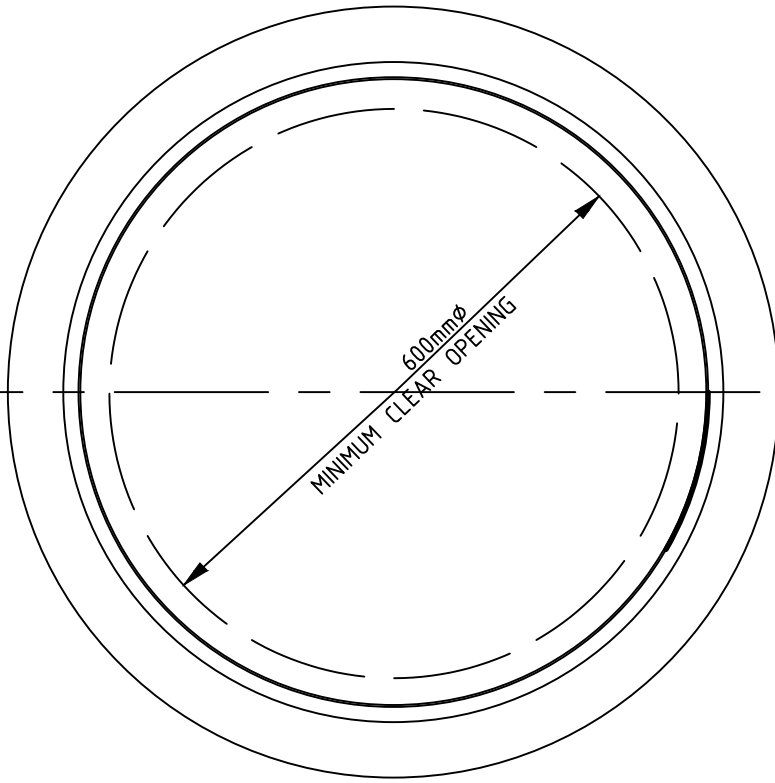

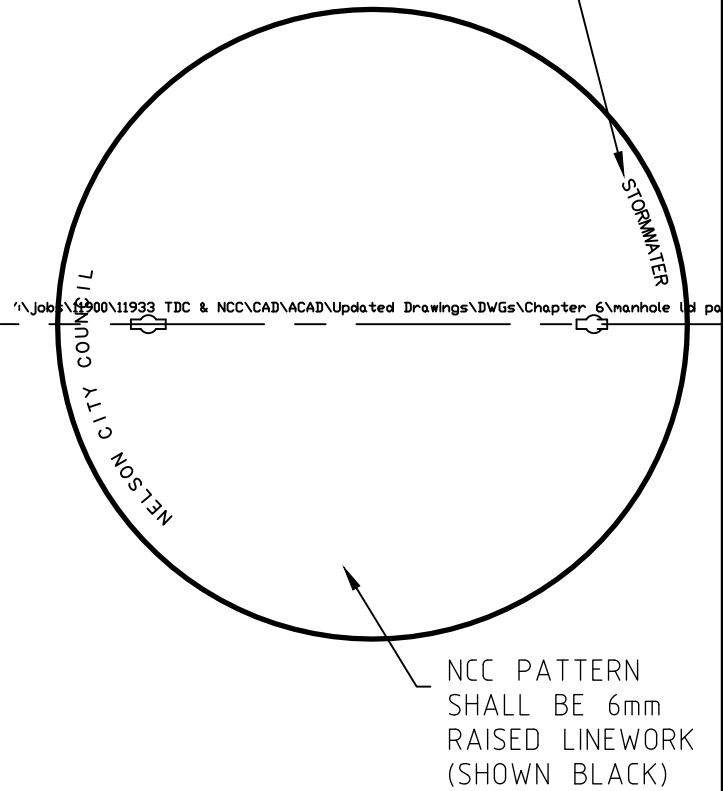

PLAN - COVER + FRAME
(PATTERN OMITTED)



PLAN - COVER
(WITH PATTERN SHOWN)

NOTES

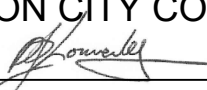
- FRAMES AND COVERS MUST HAVE THE FOLLOWING FEATURES AND BE APPROVED BY NCC:
 - DUCTILE IRON TO AS1831:2007
 - CERTIFIED TO MEET CLASS E (400kN) TO AS3996. THE CLASS STRENGTH IN KiloNewtons SHALL BE SHOWN ON THE TOPSIDE OF THE COVER
 - BE 'ANTI-ROCKING' (ie. MUST HAVE SPECIFIC FEATURES THAT PREVENT THE COVERS RATTLING OR MAKING NOISE WHEN DRIVEN OVER BY VEHICLES)
 - SEALED TO PREVENT INFILTRATION
 - FRAME AND COVER TO HAVE NON-CAPTIVE HINGE ALLOWING EASIER LIFTING OF THE COVER TO UPRIGHT POSITION, WITH THE ABILITY TO REMOVE THE COVER FROM THE FRAME
 - PARTIAL LOCKING MECHANISMS THAT PREVENT THE COVER OPENING UNDER SMALL SURGES OF BACK PRESSURE
 - COVERS MUST HAVE THE NCC PATTERN INCORPORATED ONTO THE COVER AS DETAILED IN THE PLAN ABOVE
- FRAME AND COVERS THAT MEET THE ABOVE CRITERIA AND WHICH HAVE ALREADY BEEN APPROVED BY NCC FOR USE IN NELSON CITY AREA ARE:
 - THE MAESTRO ROADWAY CLASS E 400kN FRAME AND COVER PRODUCED BY EJ

NELSON CITY COUNCIL  GROUP MANAGER INFRASTRUCTURE, NELSON		NCC STANDARD PATTERN FOR 600mmØ (NOMINAL) D.I. FRAME AND COVER	
TASMAN DISTRICT COUNCIL  ENGINEERING SERVICES MANAGER, TASMAN	DATE 01/07/19	NELSON - TASMAN LAND DEVELOPMENT MANUAL	605

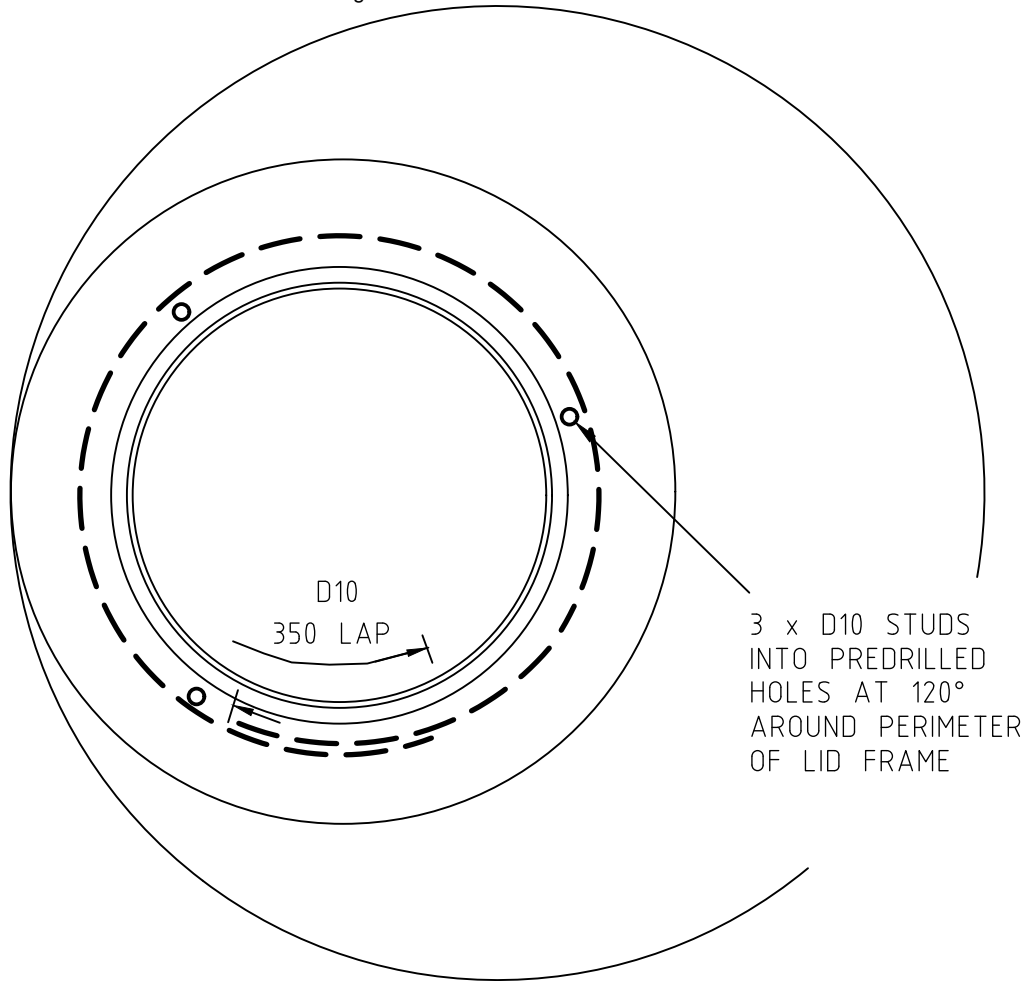

PLAN

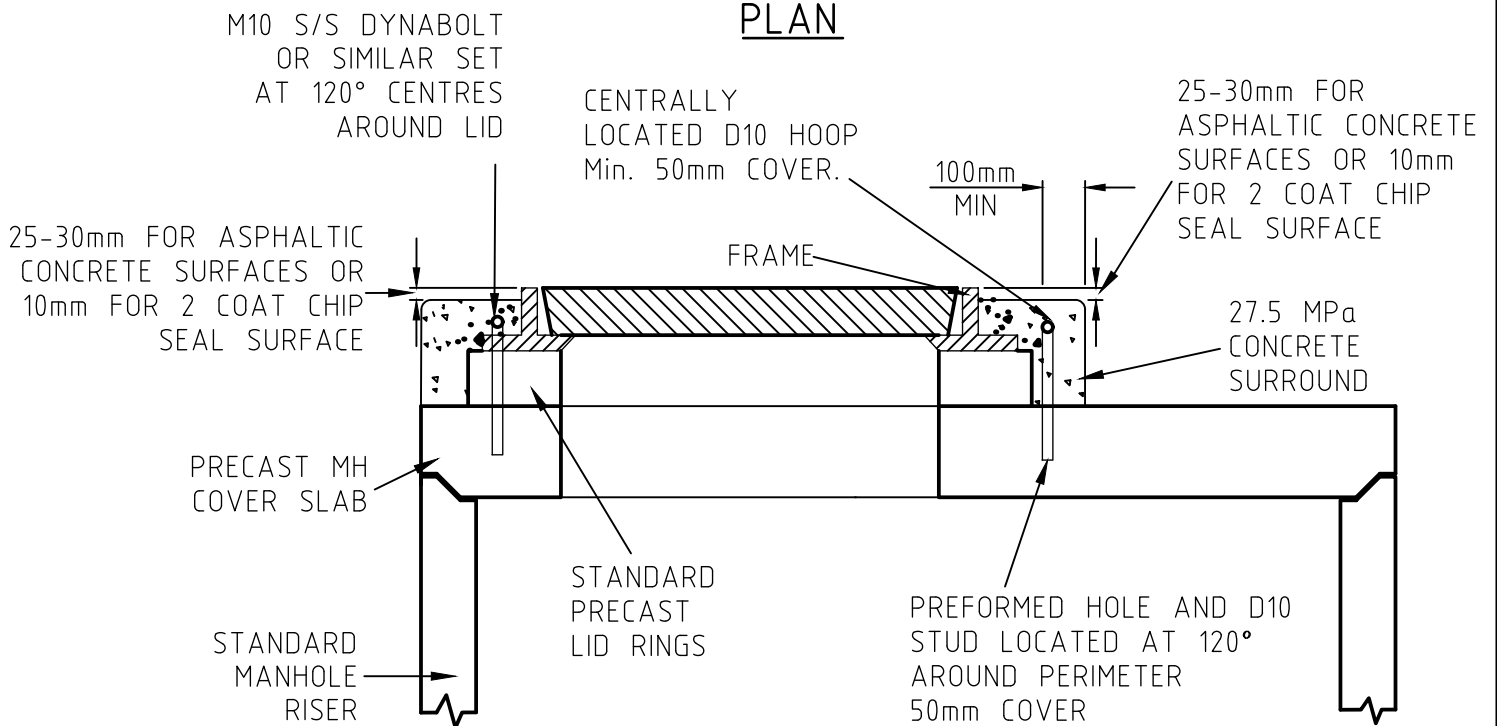

NELSON CITY COUNCIL

[Signature]
GROUP MANAGER INFRASTRUCTURE, NELSON

MANHOLE FRAME & COVER FIXING, DYNABOLT OR SIMILAR OR REINFORCING FRAME & CONCRETE

TASMAN DISTRICT COUNCIL

[Signature]
ENGINEERING SERVICES MANAGER, TASMAN

DATE
01/07/19

NELSON - TASMAN
LAND DEVELOPMENT MANUAL

606

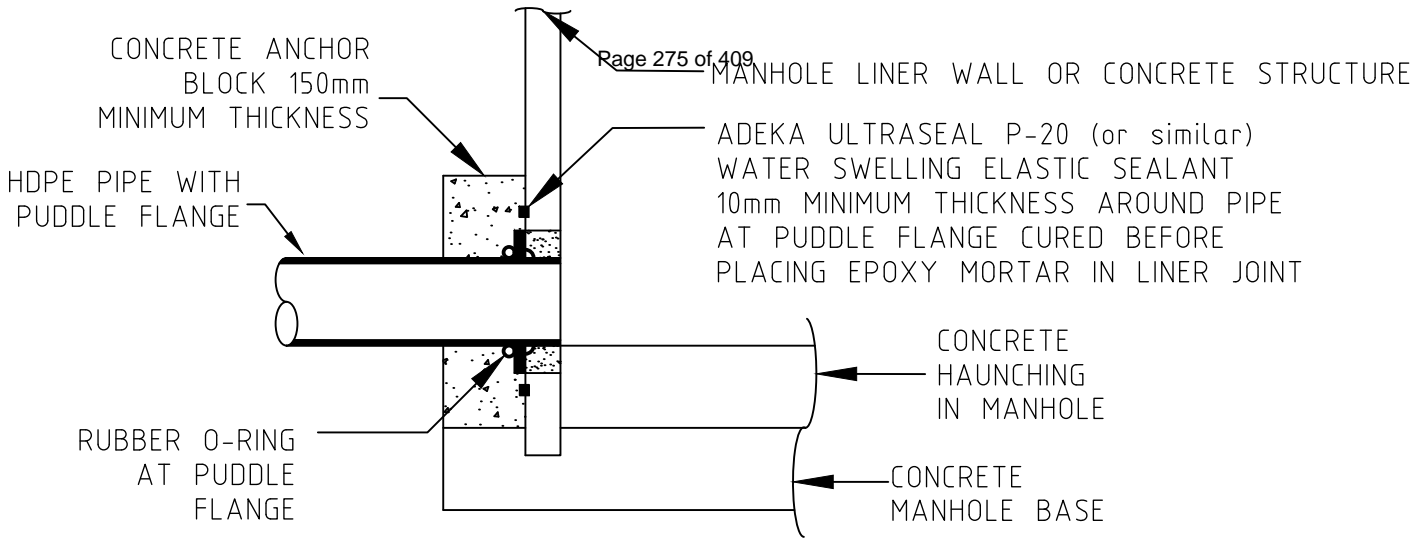

HDPE PIPES

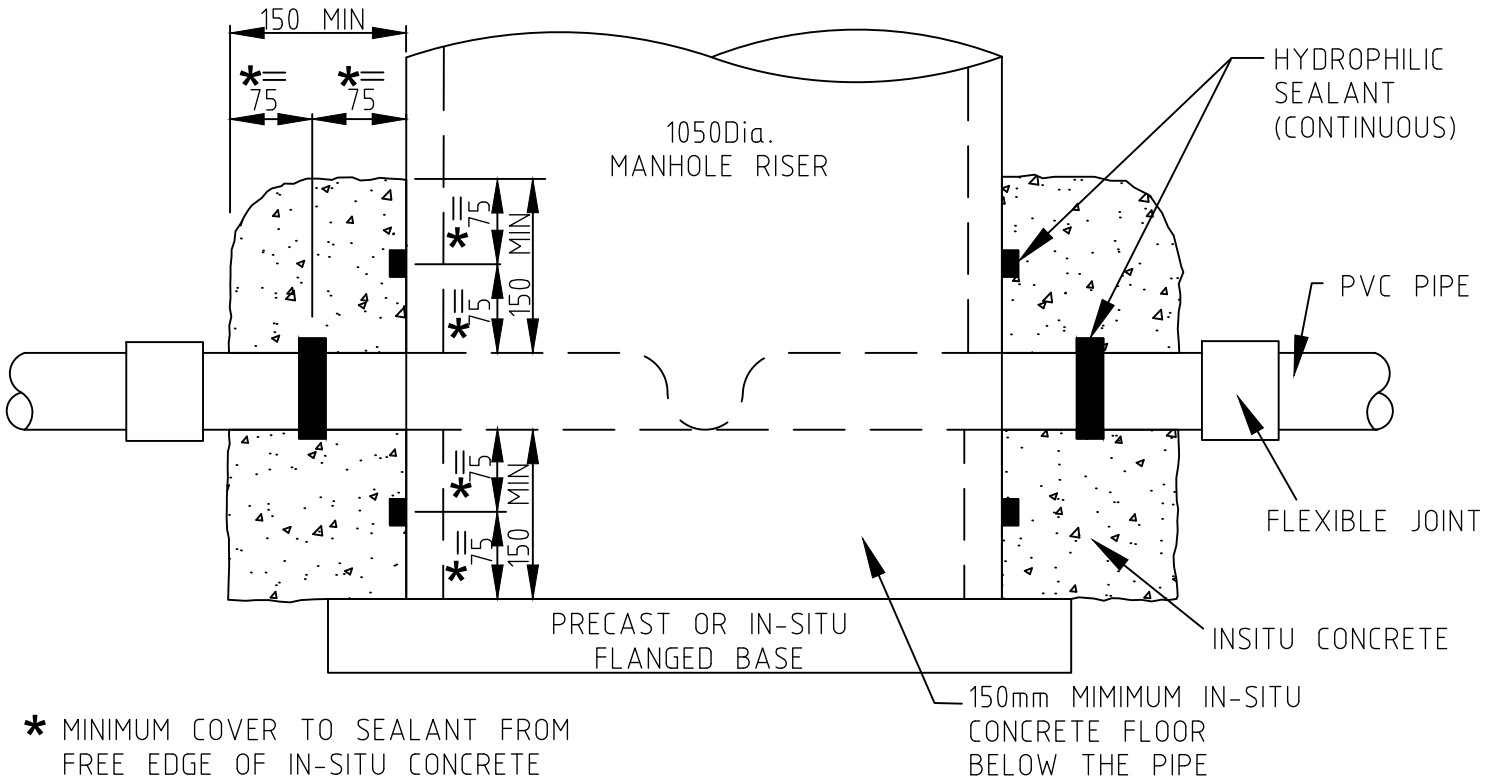

PVC PIPES

NOTES

1. HYDROPHILLIC SEALANT TO BE ADEKA ULTRASEAL P-201 (OR SIMILAR) WATER SWELLING ELASTIC SEALANT 10mm MIN. THICKNESS AROUND THE PIPE CURED BEFORE PLACING IN-SITU CONCRETE.
2. DETAIL APPLIES TO ALL WASTEWATER MANHOLES WHERE THE WASTEWATER PIPELINE MAY BE DEEPER THAN THE WATER TABLE &/OR WHERE TRENCH DRAINAGE (SEE DRAWING 613) IS NOT POSSIBLE WRAP EACH INCOMING & OUTGOING PIPE WITH HYDROPHILLIC SEALANT PRIOR TO CONCRETE POUR
3. HYDROSTATIC WATER TEST EACH SEALED MANHOLE PRIOR TO BACKFILLING MANHOLES
4. ALL WORKS TO BE INSPECTED BY COUNCIL PRIOR TO PLACING OF IN-SITU CONCRETE

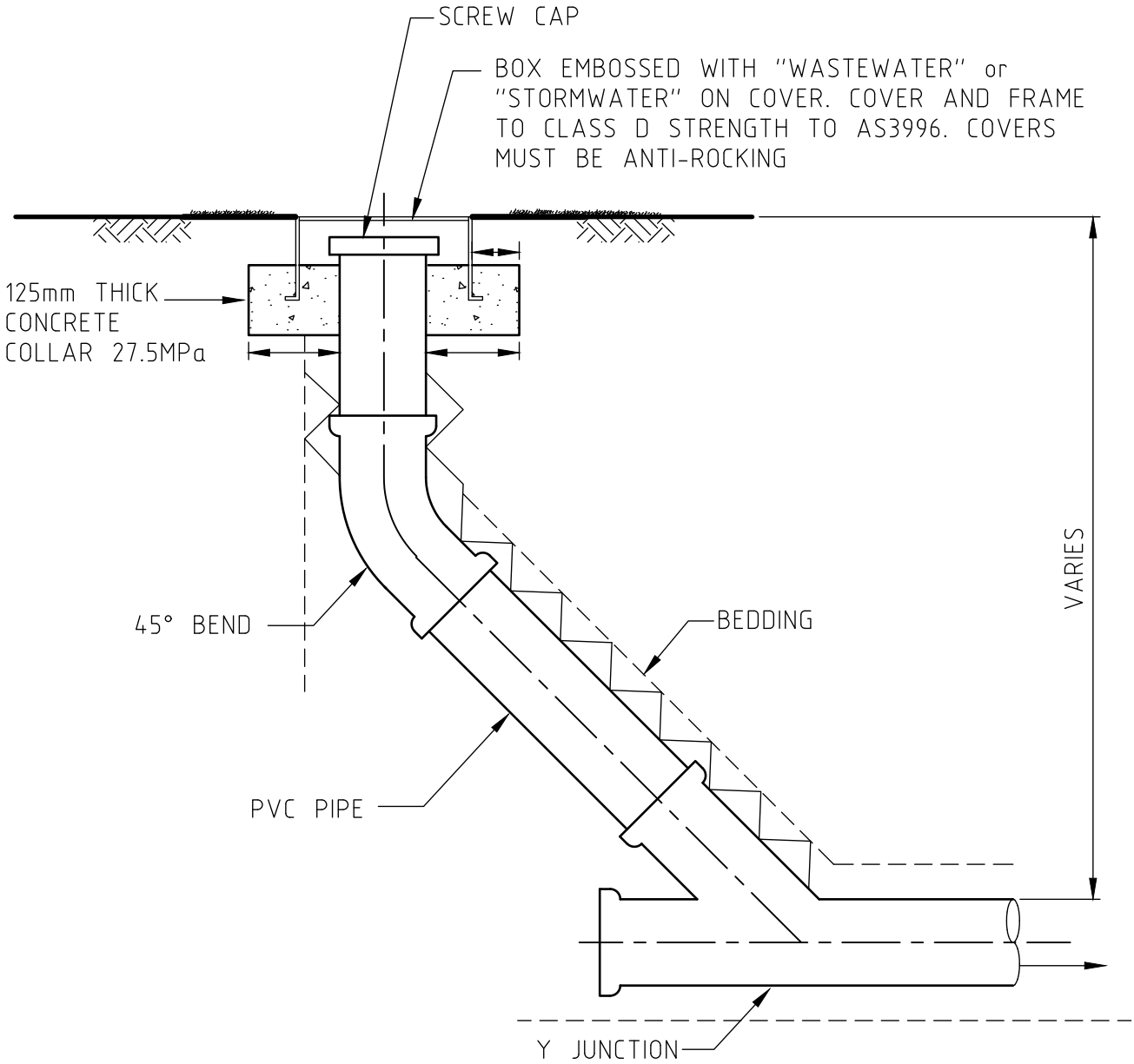

<p>NELSON CITY COUNCIL</p> <p><i>[Signature]</i></p> <p>GROUP MANAGER INFRASTRUCTURE, NELSON</p>		<p>WASTEWATER MANHOLE WATER TIGHTNESS & PIPE RESTRAINT FOR HDPE / PVC PIPES</p>	
<p>TASMAN DISTRICT COUNCIL</p> <p><i>[Signature]</i></p> <p>ENGINEERING SERVICES MANAGER, TASMAN</p>		<p>DATE</p> <p>01/07/19</p>	<p>NELSON - TASMAN</p> <p>LAND DEVELOPMENT MANUAL</p>
			<p>607</p>



FOR TRAFFIC LOADED RODING POINTS REFER TO DRAWING 610

NOTES

1. RODING POINTS MAY BE USED IN LIEU OF MANHOLES IN ANY OR ALL OF THE FOLLOWING CIRCUMSTANCES:
 - A) AT CHANGE OF DIRECTION OR GRADE. (BURIED, PRE-FORMED BENDS MAY BE USED IN LIEU OF RODING POINT WHERE THE CHANGE ON DIRECTION OR GRADE IS CLOSER THAN 20m FROM A RODING POINT OR MANHOLE
 - B) AT THE HEAD OF A WASTEWATER SYSTEM
 - C) AT THE TOP OF STEEP BANKS WHERE A STANDARD MANHOLE WOULD BE IMPRACTICAL

<p>NELSON CITY COUNCIL</p>  <p>GROUP MANAGER INFRASTRUCTURE, NELSON</p>	<p>RODING POINT (NON TRAFFIC LOADED)</p>		
<p>TASMAN DISTRICT COUNCIL</p>  <p>ENGINEERING SERVICES MANAGER, TASMAN</p>	<p>DATE</p> <p>01/07/19</p>	<p>NELSON - TASMAN LAND DEVELOPMENT MANUAL</p>	<p>608</p>

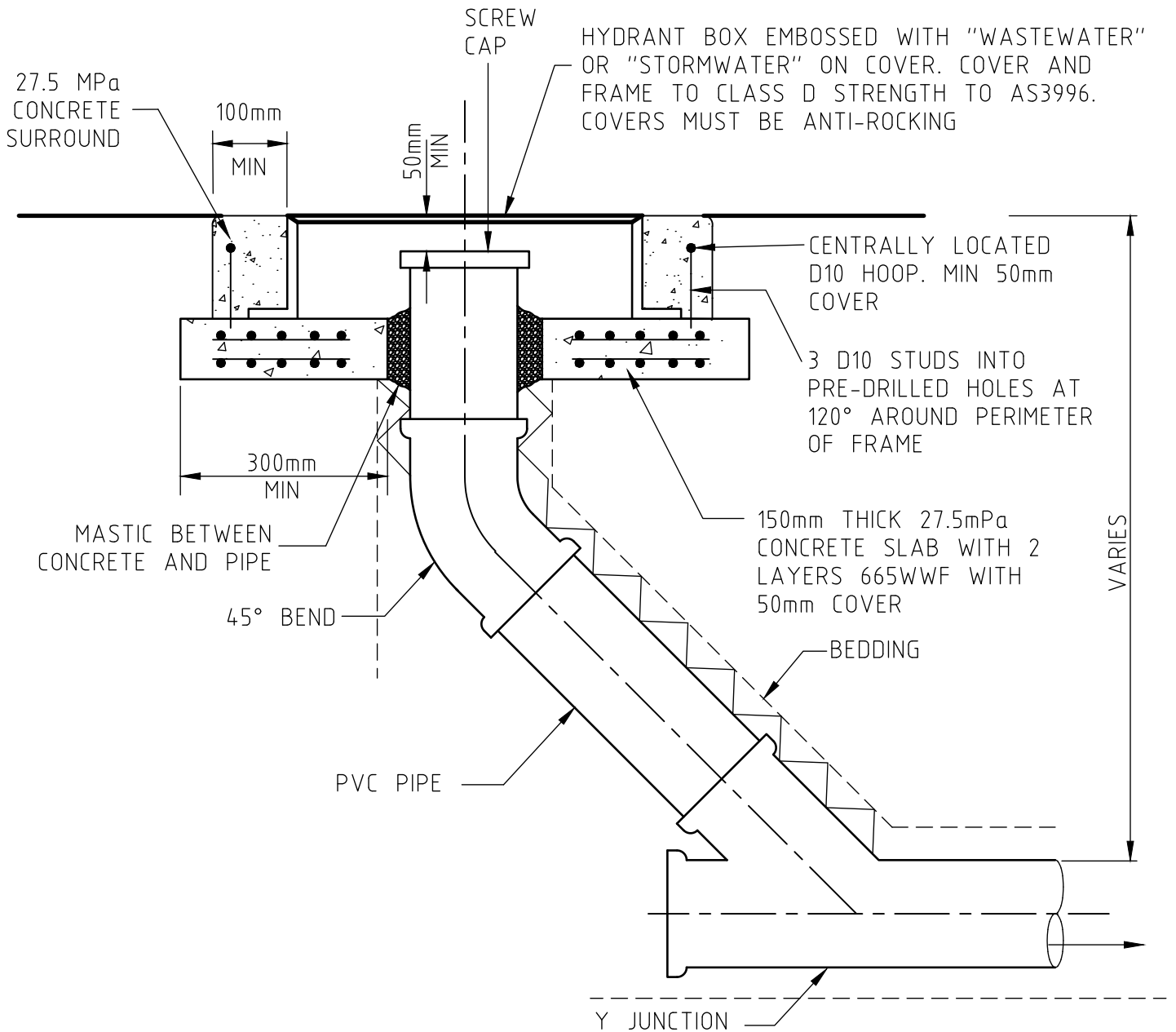

FOR NON TRAFFIC LOADED RODING POINTS REFER TO DRAWING 608

NOTES

1. RODING POINTS MAY BE USED IN LIEU OF MANHOLES IN ANY OR ALL OF THE FOLLOWING CIRCUMSTANCES:
 - A) AT CHANGE OF DIRECTION OR GRADE. (BURIED, PRE-FORMED BENDS MAY BE USED IN LIEU OF RODING POINT WHERE THE CHANGE ON DIRECTION OR GRADE IS CLOSER THAN 20m FROM A RODING POINT OR MANHOLE
 - B) AT THE HEAD OF A WASTEWATER SYSTEM
 - C) AT THE TOP OF STEEP BANKS WHERE A STANDARD MANHOLE WOULD BE IMPRACTICAL

<p>NELSON CITY COUNCIL</p> <p><i>[Signature]</i></p> <p>GROUP MANAGER INFRASTRUCTURE, NELSON</p>	<p>RODING POINT (TRAFFIC LOADED)</p>		
<p>TASMAN DISTRICT COUNCIL</p> <p><i>[Signature]</i></p> <p>ENGINEERING SERVICES MANAGER, TASMAN</p>	<p>DATE</p> <p>01/07/19</p>	<p>NELSON - TASMAN LAND DEVELOPMENT MANUAL</p>	<p>609</p>

SEWER

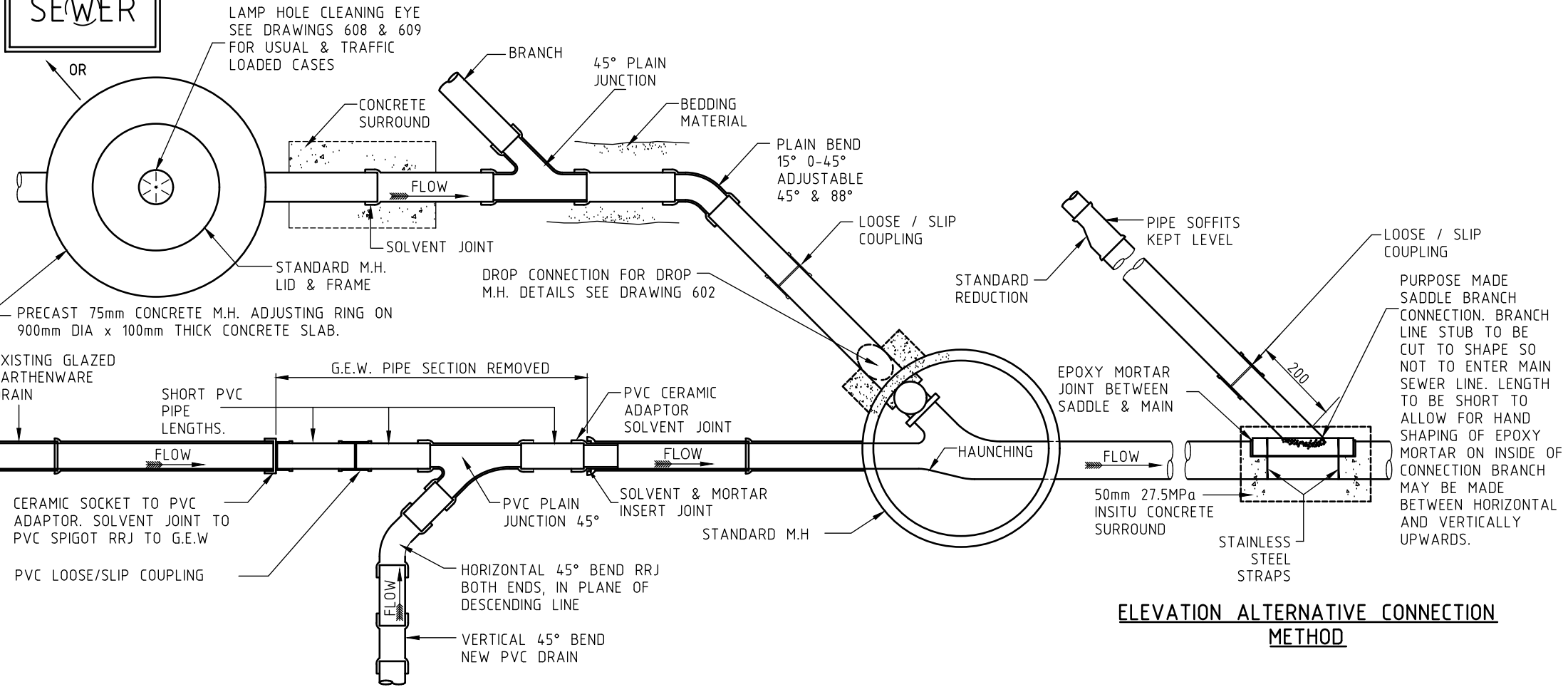

ELEVATION ALTERNATIVE CONNECTION METHOD

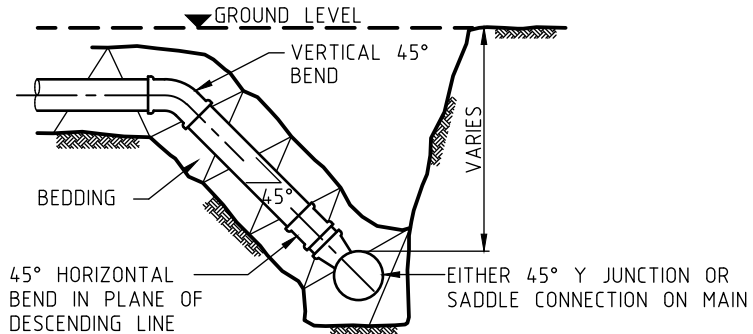

RAMPED CONNECTION ELEVATION

SCHEMATIC OF ELEMENTS USED IN PVC DRAIN CONSTRUCTION

PREFERRED CONNECTION METHOD

SIMILAR SYSTEM TO BE USED CONNECTING INTO EXISTING PVC PIPELINES.
PVC CONNECTIONS AS DETAILED TO BE USED IN NEW PVC DRAINS.

NELSON CITY COUNCIL GROUP MANAGER INFRASTRUCTURE, NELSON		STANDARD PVC PIPE DETAILS	
TASMAN DISTRICT COUNCIL ENGINEERING SERVICES MANAGER, TASMAN	DATE 01/07/19	NELSON - TASMAN LAND DEVELOPMENT MANUAL	610

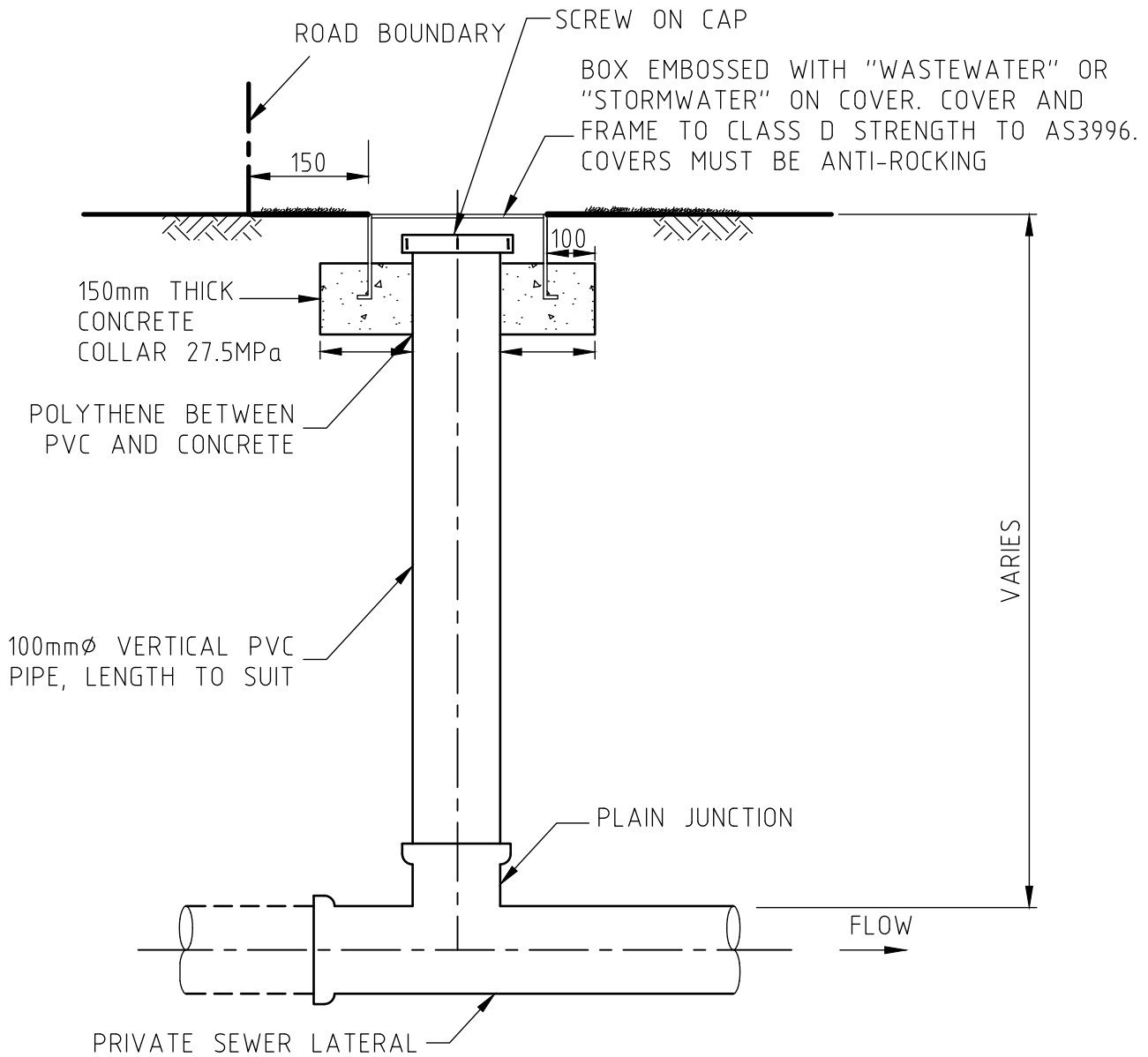

NOTES

1. IF USED IN AREAS SUBJECT TO VEHICULAR TRAFFIC, THEN USE A TRAFFIC LOADED LID DESIGN, AS PER DRAWING 609
2. INSPECTION TEES SHALL BE POSITIONED 150mm ON THE ROAD RESERVE SIDE OF THE BOUNDARY

<p>NELSON CITY COUNCIL</p> <p><i>[Signature]</i></p> <p>GROUP MANAGER INFRASTRUCTURE, NELSON</p>		<p>INSPECTION TEE</p>	
<p>TASMAN DISTRICT COUNCIL</p> <p><i>[Signature]</i></p> <p>ENGINEERING SERVICES MANAGER, TASMAN</p>	<p>DATE</p> <p>01/07/19</p>	<p>NELSON - TASMAN</p> <p>LAND DEVELOPMENT MANUAL</p>	<p>611</p>

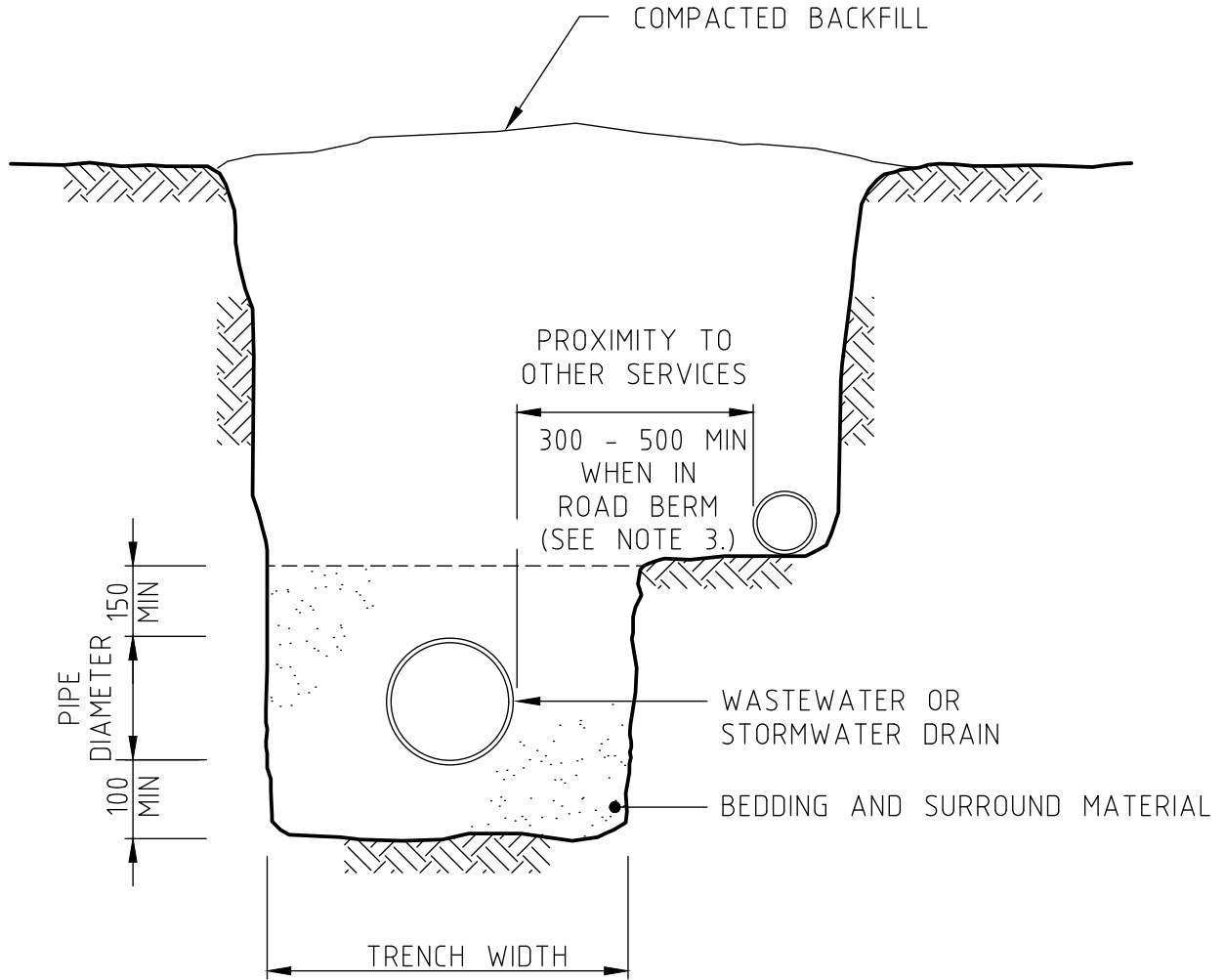

NOTES

1. SEE DRAWING 614 FOR TRENCH WIDTHS
2. THE TRENCH WIDTH SHALL BE THE MINIMUM NECESSARY TO ADEQUATELY AND SAFELY LAY THE PIPE AND TO COMPACT THE SIDE SUPPORT ZONE
3. A MINIMUM HORIZONTAL SEPARATION OF 300mm MAY BE USED WHERE 500mm IS NOT PRACTICAL

<p>NELSON CITY COUNCIL</p> <p><i>[Signature]</i></p> <p>GROUP MANAGER INFRASTRUCTURE, NELSON</p>	<p>DRAINAGE SHARED TRENCH CLEARANCES</p>		
<p>TASMAN DISTRICT COUNCIL</p> <p><i>[Signature]</i></p> <p>ENGINEERING SERVICES MANAGER, TASMAN</p>	<p>DATE</p> <p>01/07/19</p>	<p>NELSON - TASMAN</p> <p>LAND DEVELOPMENT MANUAL</p>	<p>612</p>

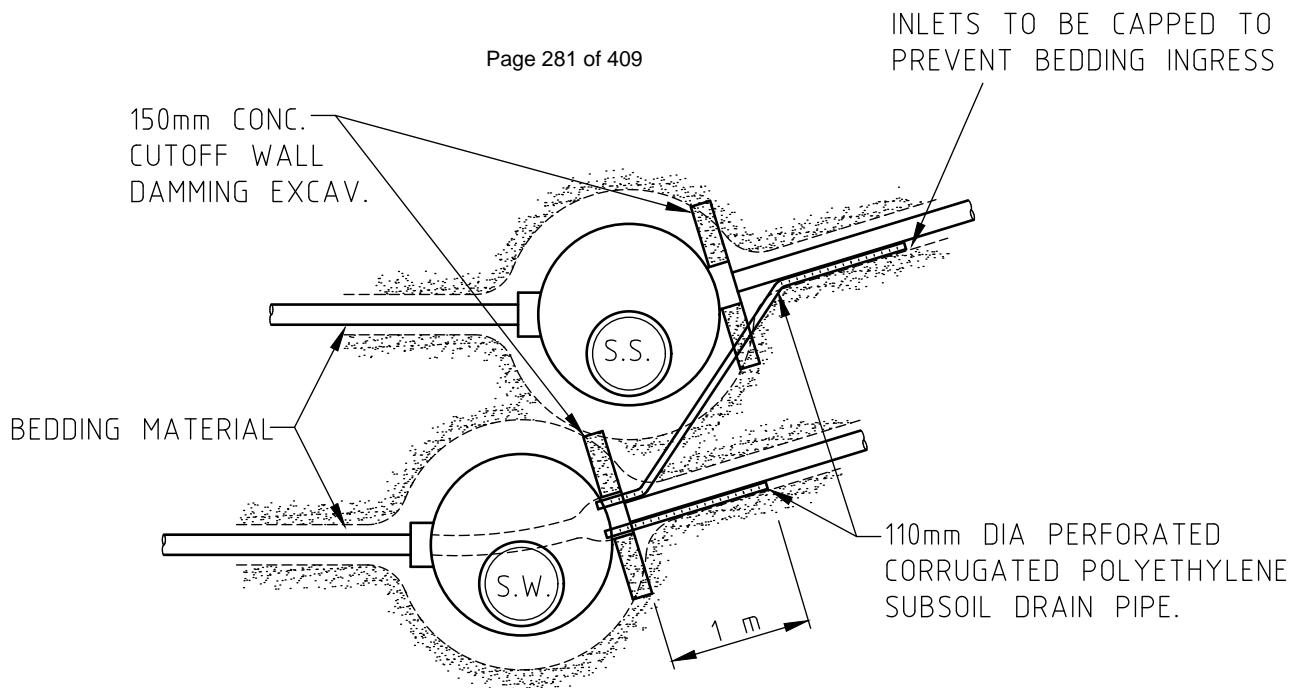

PLAN

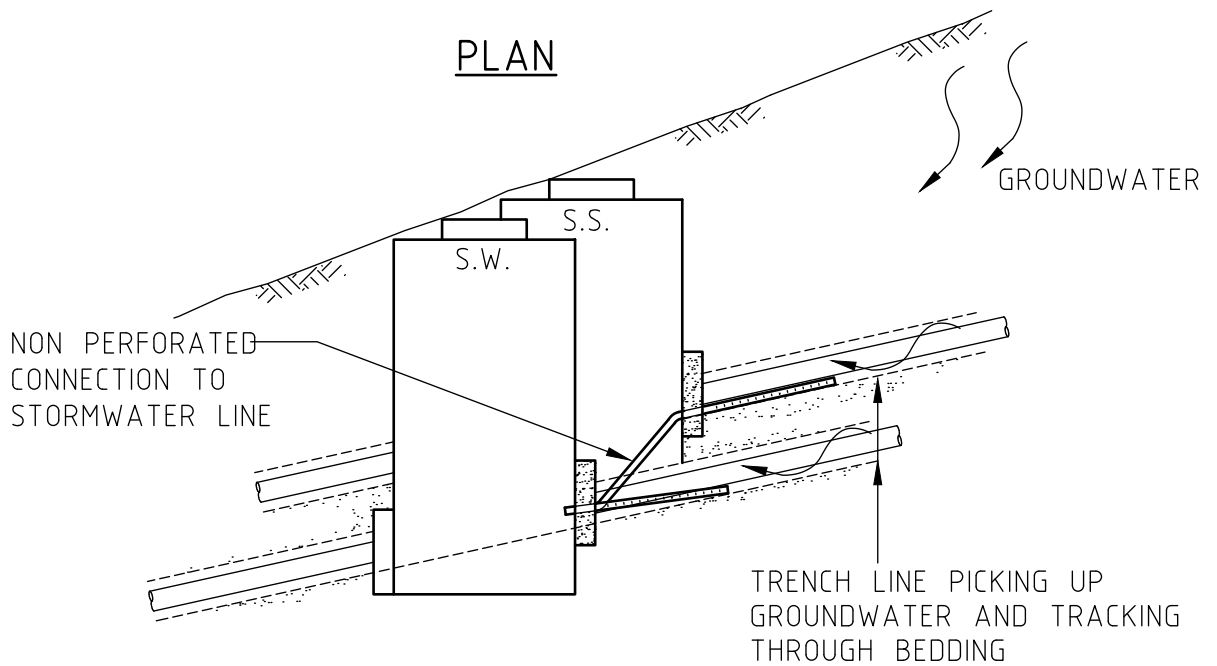

ELEVATION

NOTES

1. SIMILAR PROVISION FOR DRAINAGE OF CABLE AND WATER TRENCHES MAY BE REQUIRED
2. STORMWATER TRENCHES TO BE LAID SLIGHTLY DEEPER THAN SEWER TRENCHES WHERE POSSIBLE.
3. WHERE DRAINAGE OF THE WASTEWATER IS NOT POSSIBLE, ADDITIONAL WATERTIGHT CONSTRUCTION WILL BE REQUIRED. ALTERNATIVELY, AN APPROVED THERMOPLASTIC MANHOLE MAY BE PERMITTED.

<p>NELSON CITY COUNCIL</p> <p><i>[Signature]</i></p> <p>GROUP MANAGER INFRASTRUCTURE, NELSON</p>		<p>TRENCH DRAINAGE DETAILS</p>	
<p>TASMAN DISTRICT COUNCIL</p> <p><i>[Signature]</i></p> <p>ENGINEERING SERVICES MANAGER, TASMAN</p>	<p>DATE</p> <p>01/07/19</p>	<p>NELSON - TASMAN</p> <p>LAND DEVELOPMENT MANUAL</p>	<p>613</p>

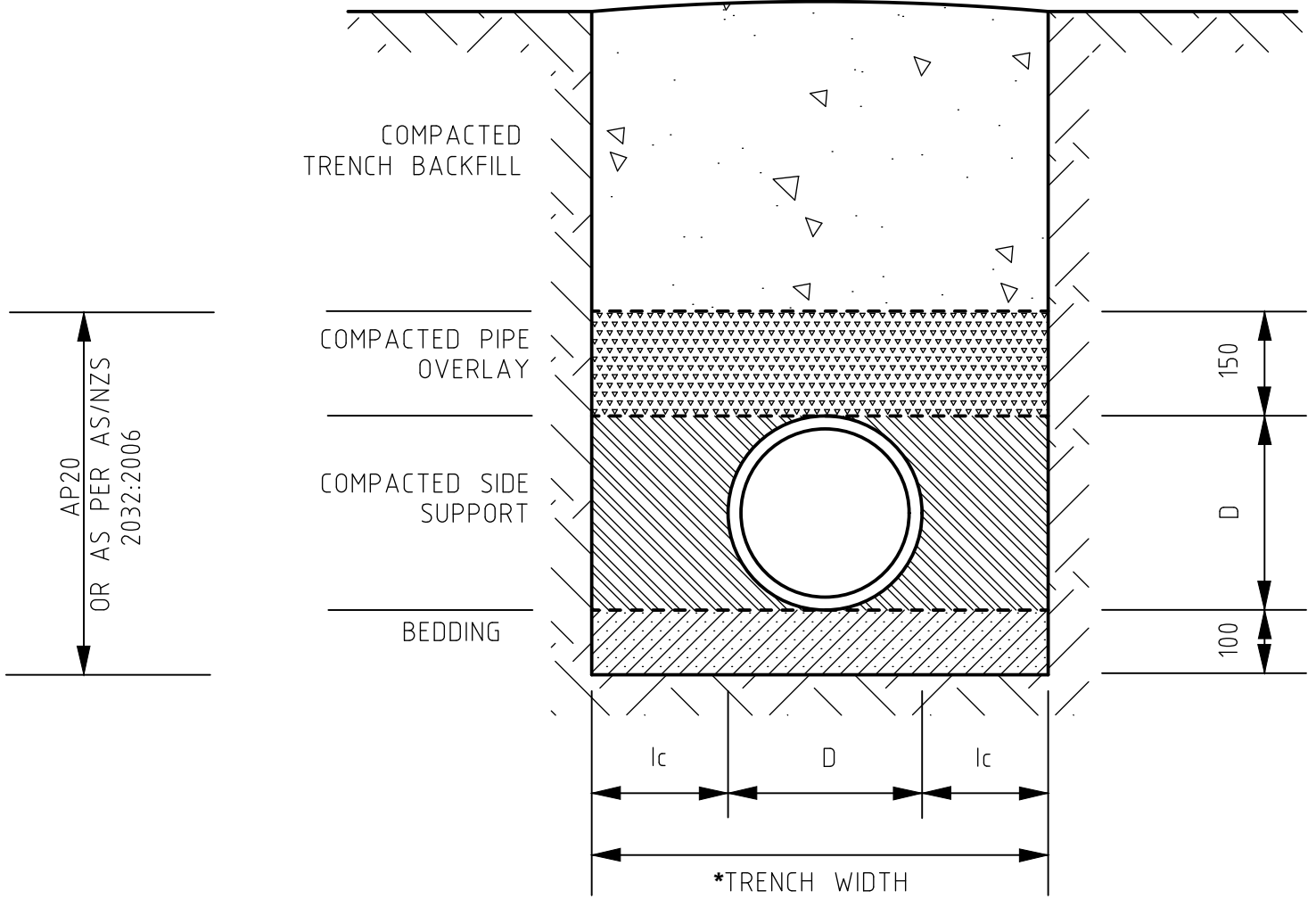

***TRENCH WIDTH**

NOMINAL DIAMETER DN (mm)	MINIMUM TRENCH SIDE CLEARANCE " l_c " TO AS/NZS 2566	* MAXIMUM
UP TO 150	100	600
200 - 250	150	600
300 - 375	200	775

THE TRENCH WIDTH SHALL BE THE MINIMUM NECESSARY TO ADEQUATELY AND SAFELY LAY THE PIPE AND TO COMPACT THE SIDE SUPPORT ZONE

<p>NELSON CITY COUNCIL</p> <p><i>[Signature]</i></p> <p>GROUP MANAGER INFRASTRUCTURE, NELSON</p>	<p>PIPE BEDDING FOR PVC, PE & OTHER FLEXIBLE PIPES</p>		
<p>TASMAN DISTRICT COUNCIL</p> <p><i>[Signature]</i></p> <p>ENGINEERING SERVICES MANAGER, TASMAN</p>	<p>DATE</p> <p>01/07/19</p>	<p>NELSON - TASMAN LAND DEVELOPMENT MANUAL</p>	<p>614</p>

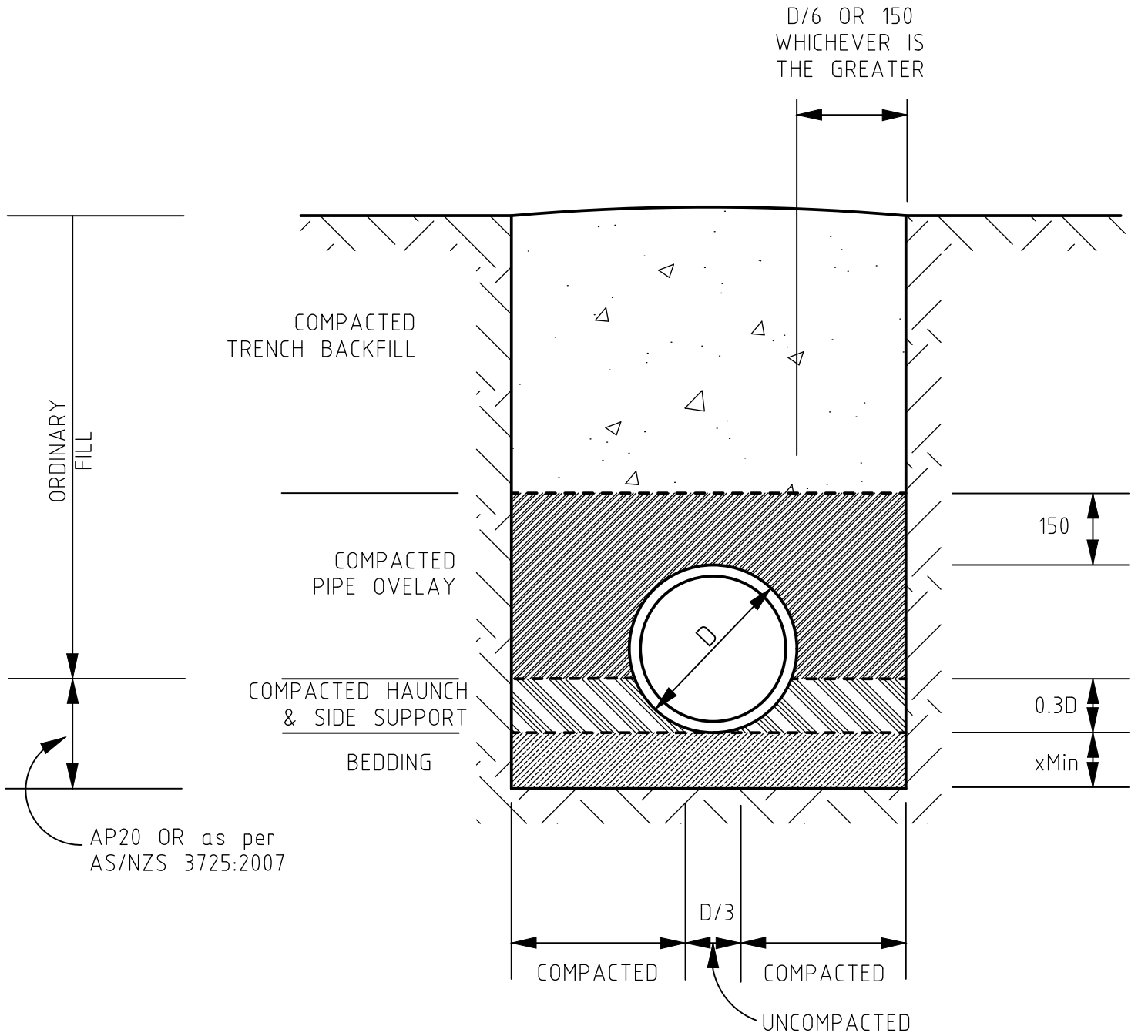

x = 100mm if D ≤ 1500
 x = 150mm if D > 1500

<p>NELSON CITY COUNCIL</p> <p><i>[Signature]</i></p> <p>GROUP MANAGER INFRASTRUCTURE, NELSON</p>	<p>PIPE BEDDING FOR CONCRETE PIPES</p>		
<p>TASMAN DISTRICT COUNCIL</p> <p><i>[Signature]</i></p> <p>ENGINEERING SERVICES MANAGER, TASMAN</p>	<p>DATE</p> <p>01/07/19</p>	<p>NELSON - TASMAN LAND DEVELOPMENT MANUAL</p>	<p>615</p>

WASTEWATER VALVE CODING:

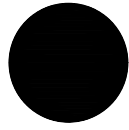

RISING MAIN SCOUR



SWALLOW CONNECTION
to GRAVITY MAIN



RISING MAIN
LINE VALVE



SWALLOW MAIN
LINE VALVE



GRAVITY MAIN LINE
VALVE at PUMPSTATION

NOTES:

1. PAINT FOR WASTEWATER MARKINGS SHALL BE NZTA M07 "ROAD MARKING PAINT" - RED

NELSON CITY COUNCIL  GROUP MANAGER INFRASTRUCTURE, NELSON		WASTEWATER VALVE ROAD MARKINGS	
TASMAN DISTRICT COUNCIL  ENGINEERING SERVICES MANAGER, TASMAN	DATE 01/07/19	NELSON - TASMAN LAND DEVELOPMENT MANUAL	616



Chapter 7

Water

TABLE OF CONTENTS

CHAPTER 7	WATER	1
INTRODUCTION		1
7	PURPOSE	1
7.1	Performance Outcomes	1
7.2	Referenced Documents	2
7.2.1	District Plan Requirements	2
7.2.2	Building Code Requirements	2
7.2.3	External Standards	2
STANDARDS		4
7.3	Reticulation Design	4
	Mandatory Matters	4
7.3.1	General	4
7.3.2	Capacity and Layout	4
7.3.3	Structural Integrity	5
7.3.4	Level of Service	5
7.3.5	Design	5
7.3.6	Permitted Head Losses	6
7.3.7	Reservoir Head	6
7.3.8	Normal Working Demand Flows	6
7.3.9	Fire Fighting Demand Flows	6
7.3.10	Alterations to Existing Infrastructure	7
7.3.11	Depth of Water Mains	7
7.3.12	Level of Service	8
7.3.13	Water Pressure and Storage Requirements	8
7.4	Pipe Specifications	8
	Mandatory Matters	8
7.4.1	Pipe Size	8
7.4.2	Pipe Materials	9
7.4.3	Pipe Joints	10
7.4.4	Unrestrained Mechanical Couplings	10
7.4.5	PVC Pipe Joints	10
7.4.6	PE Pipe Joints	11
7.4.7	Welded Steel Pipe Joints	11
7.4.8	Seismic Design for Pipes	12
7.4.9	Watermains in Hydrocarbon Contaminated Ground	12
7.5	Fittings	12
	Mandatory Matters	12
7.5.1	Pipe Fittings	13
7.5.2	Corrosion Protection	13
7.5.3	Hydrants	14
7.5.4	Positioning of Valves	15
7.5.5	Depth of Valves	15
7.5.6	Sluice Valves	15
7.5.7	Rider Main Valves	15

7.5.8	Air Release Valves.....	15
7.5.9	Scour Valves.....	16
7.5.10	Butterfly Valves.....	16
7.5.11	Non-Testable Non-Return Valves.....	16
7.5.12	Valve Boxes.....	16
7.5.13	Restraint blocks.....	17
7.5.14	Thrust Block design.....	17
7.6	Water Supply Connections.....	19
	Mandatory Matters.....	19
7.6.1	Point of supply to customer.....	19
7.6.2	Service Connection Diameter.....	19
7.6.3	Individual Connections.....	19
7.6.4	Tapping Bands and Ferrules.....	19
7.6.5	Meter Assembly for 20mm and 25mm ID Connection.....	20
7.6.6	Meter Assembly for 32 - 40mm ID Connection.....	20
7.6.7	Meter assembly for 50mm ID and larger Connection.....	21
7.6.8	Water Meters.....	21
7.6.9	Backflow Preventers.....	22
7.6.10	Reuse of Existing Service Connections.....	22
7.6.11	Disconnections.....	22
7.6.12	Fire Sprinkler Supply.....	22
	Good Practice.....	23
7.6.13	General.....	23
7.7	Pumping and Storage.....	23
	Mandatory Matters.....	23
7.7.1	Pump Station Design.....	23
7.7.2	Access and Services.....	24
7.7.3	Electrical Equipment.....	24
7.7.4	Commissioning.....	25
7.7.5	Reservoir Requirements.....	25
7.7.6	Security of Water Supply Facilities.....	25
7.7.7	Private Pumping Stations.....	25
7.8	Construction and Installation.....	25
	Mandatory Matters.....	25
7.8.1	Trench Width.....	26
7.8.2	Base of Excavation.....	26
7.8.3	Trench Support.....	26
7.8.4	Trench Foundation Stability.....	26
7.8.5	Dewatering.....	26
7.8.6	Metal Bedding.....	26
7.8.7	Pipe Embedment.....	27
7.8.8	Geotextiles.....	27
7.8.9	Concrete Protection.....	27
7.8.10	Water Stops and Trench Groundwater.....	27
7.8.11	Pipe Installation.....	28
7.9	Trenchless Technology.....	28
	Mandatory Matters.....	28
7.9.1	General.....	28
7.9.2	Tracer Tape.....	29
7.9.3	Tracer Tape Installation.....	29
7.9.4	Tracer Wire.....	29

7.9.5	Tape or Wire Testing	29
7.9.6	Testing, Disinfection and Connection	30
	Good Practice.....	30
7.9.7	Trenching	30

LIST OF TABLES

Table 7-1	Standards and Publications Related to the Design and Construction of Water Supply Services ..	2
Table 7-2	Water Supply Levels of Service	5
Table 7-3	Design Demand Flows	6
Table 7-4	SNZ PAS 4509 Fire Fighting Flow, Pressure and Storage Requirements	8
Table 7-5	General Pipe Specifications	9
Table 7-6	Pipe Thrust Block Design.....	18
Table 7-7	Approved Water Meters and Meter Boxes	21
Table 7-8	Water Stops Spacing and Gradient	28

APPENDICES

Appendix A	Water Meter Location Form
Appendix B	Rural Water Supply – Tasman District Council Only

CHAPTER 7 WATER

INTRODUCTION

7 PURPOSE

The Council seeks to create and manage a water supply network that will distribute water for consumption and fire-fighting purposes, and which meets the appropriate standards and level of service for these uses, delivered in an efficient, safe and sustainable way.

7.1 Performance Outcomes

Water supply performance outcomes for network assets sought by these standards are set out as follows. They are subject to the objectives, policies and rules of the Nelson and Tasman RMPs:

- a) Drinking water quality that ensures the health and safety of people and communities;
- b) A water supply network that has adequate capacity, pressure, and points of connection to provide water for all community needs including fire-fighting purposes;
- c) A water supply network that minimises risk of contamination;
- d) A water supply network that has sufficient capacity to accommodate reasonably foreseeable future demand;
- e) A network that is located in such a way as to adequately service each lot;
- f) A network that is accessible for maintenance;
- g) New supply infrastructure that will minimise adverse effects on, and be compatible with, the existing water reticulation network, including existing equipment used by Council;
- h) A water supply network that will minimise disruption to other parts of the network during maintenance by having adequate interconnections, valves, and separating trunk main supplies from local reticulation;
- i) Is located, constructed and uses materials in a manner that minimises the potential for damage or disruption due to natural hazards;
- j) A network that is robust and durable, able to withstand, external pressures such as tree roots and ingress of contaminants, as well as internal pressures such as water chemistry and pressure surges; and
- k) A network that is affordable over the whole-of-life of the system, including maintenance, operations and replacement or renewal costs.
- l) Water is sourced in a manner that protects the mauri of water and opportunities for Mahinga kai.

All performance outcomes are also subject to the applicable RMP objectives and policies and appropriate water supply bylaws which take precedence over the requirements of the Nelson Tasman Land Development Manual (NTLDM).

7.2 Referenced Documents

7.2.1 District Plan Requirements

The standards set out in this chapter address matters that are specific to Council asset creation or activities that may have an impact on an asset. They are subject to the respective Nelson City and Tasman District RMPs. Regarding water supply, key sections are subdivision and land use building construction and alteration.

7.2.2 Building Code Requirements

Private property connection to a Council provided water supply is also addressed under the Building Act and NZ Building Code (NZBC).

A Building consent is required for that connection and is to be supported with the appropriate plans and specifications (Section 45 of the Building Act 2004) that demonstrate compliance with the performance requirements of NZBC clause G12 (“Water supplies”). The information required includes, but is not limited to, the setting out of the water pipe, from the boundary of the property to the building(s) concerned, plus measures to protect the pipework.

7.2.3 External Standards

Unless otherwise specified within the standards of this document, water supply networks will be designed and constructed in a manner consistent with the standards set out in Table 7-1. Where an Act or National Standards document is referenced, this will be the current version including any associated amendments.

Table 7-1 Standards and Publications Related to the Design and Construction of Water Supply Services

Standard	Comment
	Council traffic management guidelines
SNZ PAS 4509	New Zealand Fire Service Fire Fighting Water Supplies Code of Practice
NZS 4404:2010	Land development and subdivision engineering
NZS/BS 21	Pipe threads for tubes and fittings
NZS 4522	Underground fire hydrants and surface box frames and fittings
AS/NZS 4793	Mechanical tapping bands for waterworks purposes
AS1646	Elastomeric seals for water works purposes
AS/NZS 1477	PVC Pipes and fittings for pressure applications
AS/NZS 2032	Installation of PVC pipe systems
AS/NZS 2033	Installation of polyethylene pipe systems
AS 2129	Flanges for pipes
AS/NZS 2280	Ductile iron pipes and fittings
AS/NZS 2544	Grey iron pressure fittings
AS/NZS 2566	Part 1 Buried flexible pipelines – Structural design Part 1 Supplement 1: Buried flexible pipelines – Structural design – Commentary Part 2 Buried flexible pipelines - Installation



Standard	Comment
AS/NZS 2638	Gate valves for water works purpose – resilient-seated
NZS 4058	Specification for pre-cast concrete drainage and pressure and non-pressure pipes
NZS 3109	Concrete construction
NZS 3121	Specification for water and aggregate for concrete
BS 3412	Methods of specifying general purpose PE materials for moulding and extrusion
NZS 3501	Specification for copper tubes for water, gas and sanitation
AS 3572	Glass filament reinforced plastics
NZS 3604	Timber framed buildings
AS/NZ S3725	Loads on buried concrete pipes
AS/NZS 4020	Testing of products for use in contact with water
AS/NZS 4087	Metallic flanges for water works purposes
AS/NZS 4129	Fittings for PE pipes for pressure applications
AS/NZS 4130	Polyethylene (PE) pipes for pressure applications
AS/NZS 4158	Thermal bonded polymeric coatings on valves and fittings for water industry purposes
AS 4181	Stainless steel clamps for water purposes
AS/NZS 4331	Metallic flanges – Part 2: Cast iron flanges
AS/NZS 4441	Oriented PVC (PVC-O) pipes for pressure applications
NZS 4442	Welded steel pipes and fittings for water, sewage, and medium pressure gas
NZS 4501	Code of practice for the location and marking of fire hydrants
AS/NZ S4765	Modified PVC (PVC – M) pipes for pressure applications
AS/NZS 4998	Bolted unrestrained mechanical couplings for waterworks purposes
NZS/BS 5163	Specification for predominantly key operated cast iron gate valves for water works purposes
AS 3571/AS 3572	Glass reinforced plastics (GRP) pipes joints and fittings
www.astt.com.au	Australasian Society of Trenchless Technology
Ministry of Business, Innovation and Employment	NZ Building Code - G12 and B2
DWSNZ	Drinking-water Standards for New Zealand
Bylaws	Nelson City Council and Tasman District Council Water Supply Bylaws

STANDARDS

7.3 Reticulation Design

This section sets out Council's expectation for the design of the layout, capacity, connection points, flow and pressure of the water supply reticulation.

Mandatory Matters

Council requires the following standards to be met in the design of the water supply reticulation:

7.3.1 General

7.3.1.1 A water supply network will deliver quality water to the point of supply that complies with the Drinking-water Standards for New Zealand 2005 (Revised 2008).

7.3.1.2 The water network will minimise the risks of contamination being introduced into the water.

7.3.2 Capacity and Layout

7.3.2.1 The water supply network will have sufficient capacity to provide adequate flow and pressure to meet the anticipated demand over its lifetime. Allowing for ultimate future development potential¹ within the catchment or adjoining catchments.

7.3.2.2 The water supply network will meet the fire protection requirements of the NZ Fire Service Fire Fighting Water Supplies Code of Practice 4509.

7.3.2.3 The water supply network will be located in such a way as to adequately service each lot and provide reasonable access for maintenance. It will not be located on private land.

7.3.2.4 The design of the water supply network will:

- a) Minimise adverse effects on, and be compatible with, the existing water reticulation network;
- b) Minimise disruption to other parts of the network during maintenance by having adequate interconnections, valves, and separating trunk main supplies from local reticulation;
- c) Utilise mechanical, electrical, alarm and telemetry equipment which is compatible with existing equipment used by Council;
- d) Make provision for access and maintenance of any component where the expected life of that component is less than that of the system of which it is a part;
- e) Ensure that mechanical and electrical equipment is either designed for submergence or located above the 100-year design flood level;
- f) Minimise whole of life costs;
- g) No water reticulation is to be constructed within private property or Council reserves;
- h) Water reticulation must be located a minimum of 1.5 metres from any boundary line.

¹ Development potential means the likely future development within the Services Overlay taking into account the Council's Strategic Development Plan and the LTP, and the provision of services in a manner that integrates with and does not foreclose this likely future development.



7.3.3 Structural Integrity

- 7.3.3.1 The water supply network will be constructed of materials compatible with the chemical properties of the water being conveyed, be suitable for the intended duty, have a minimum design life of 70 years and have a proven performance record.
- 7.3.3.2 The water supply facility will minimise leakage, eliminate the ingress of contaminants, and the penetration of roots, using current best practice.
- 7.3.3.3 The water supply facility will provide electrical and mechanical equipment with a life span and quality of the best currently available technology.
- 7.3.3.4 The facility will withstand all anticipated superimposed loads and network pressures (including those from transient surges that could reasonably be expected from pump failure, pump starts, and sudden valve closure).

7.3.4 Level of Service

- 7.3.4.1 Table 7-2 sets out the minimum levels of service required for urban water supply reticulation. Any proposed water supply system (or extension to an existing water supply system) will be adequate to meet these levels of service at the time of design and the reasonably foreseeable future.

Table 7-2 Water Supply Levels of Service

Design Criteria	Level of Service Required
SNZ PAS 4509: 2008 - NZ Fire Service Fire Fighting Water Supplies Code of Practice	Full compliance with FW2 and every part of the network
Connection	Each lot will have an individual metered connection and appropriate backflow for the site
Minimum flow at each connection	30 litres per minute for design flows (also refer to Table 7-3)
Minimum normal working residual pressure	300 kPa at the point of supply
Maximum static water pressure	900 kPa at the point of supply

Note: Any lots and buildings provided with private, on-site systems will meet the requirements of the appropriate Resource Management Plan (RMP).

7.3.5 Design

- 7.3.5.1 All proposed reticulated water supplies must comply with the minimum levels of service shown in Table 7-2 for both normal demand flows and fire-fighting flows.
- 7.3.5.2 For residential development, network design and pipe sizes will be determined by fire-fighting flows. As a minimum, the Designer must demonstrate compliance with fire-fighting code of practice.
- 7.3.5.3 Principal mains will be not less than 150mm ID (see also, Table 7-5) and will be laid on one side of all public roads in every residential development.
- 7.3.5.4 Rider mains will be not less than 50mm ID in residential development (see also Table 7-5) and will be laid along the road frontage of all lots not fronted by a principal main and looped back to the principal main to avoid dead ends. The principal mains serving commercial and industrial

developments will be at least 150mm ID on one side of the road with a 100mm ID main on the other side.

- 7.3.5.5 The Council will have the right to specify the diameters to be used for the principal water mains within the development with regard to the Council's Strategic and Management Plans.
- 7.3.5.6 Regarding working pressure or pressures at the point or points of connection to the existing reticulation, when such data is not available or at the Council's request, it will be the responsibility of the designing engineer to obtain the information through independent flow and pressure tests.

7.3.6 Permitted Head Losses

- 7.3.6.1 The new water supply reticulation will be designed to mitigate large fluctuations in residual pressure as demands vary and minimise the losses of pressure along the watermains. Head losses in the watermains will not exceed approximately 20kPa/kilometre at peak domestic demand (i.e. 2 metres of head loss per 1000 metres of pipeline). Higher losses may be approved by the Council on a case-by-case basis.

7.3.7 Reservoir Head

- 7.3.7.1 For design purposes, the hydraulic head at a reservoir will be taken with the reservoir being 50% full.
- 7.3.7.2 Water connections will be located so that properties at the highest location receive a pressure of 300kPa at the point of supply measured from the bottom operational water level of the reservoir and properties at the lowest location receive a pressure not more than 900 kPa from the top operational water level of the reservoir at the point of supply without the use of a PRV valve.

7.3.8 Normal Working Demand Flows

- 7.3.8.1 When the source of supply is a pressure-reducing valve the hydraulic head will be the head the pressure-reducing valve is set to.
- 7.3.8.2 The minimum flow and normal working residual pressure level of service criteria specified in Table 7-3 will be satisfied for all reticulation when using the following demand flows.

Table 7-3 Design Demand Flows

Development Type	Design Flows
Residential	52 litres per person per peak hour 624 litres per person per day (peak day) 1560 litres per dwelling per day (assuming 2.5 persons per dwelling)
Commercial and Industrial	Specifically assessed by the Designer

7.3.9 Fire Fighting Demand Flows

- 7.3.9.1 All reticulation (and storage) design must fully comply with the requirements of the NZ Fire Service Fire Fighting Water Supplies Code of Practice (SNZ PAS 4509), hereafter called the Code of Practice.

7.3.9.2 For compliance in residential areas under classification FW2, a simultaneous flow of 12.5 l/s is required from two fire hydrants with maximum hydrant spacing of 135.0m. Each hydrant is to be no closer than 6.0m and no further than 135.0m from the potential fire source, refer Table 7-4.

7.3.10 Alterations to Existing Infrastructure

7.3.10.1 Regarding alterations to existing reticulation, any alteration (upgrading, relocation and lowering of watermains and other water supply element(s), required for compliance of the new development to the Council's standards will be at the Developer's cost. The connections to the existing reticulation will be undertaken by a contractor approved by the Council, at the Developer's cost.

7.3.10.2 No connection to Council's reticulation will be permitted until all new reticulation has been adequately flushed of all construction debris and sterilised.

7.3.11 Depth of Water Mains

7.3.11.1 The following standards apply to the installation of water mains:

- a) Water mains will be installed to comply with SD701 to SD709 and AS/NZS 2566.2;
- b) Both principal mains and rider mains will have the following cover, except in circumstances requiring special protection. Greater depth will be provided if required by Council;
- c) Under grass berms and footpaths in residential areas, the top of pipe for water mains is 600mm below the finished surface (minimum) and 900mm (maximum). In commercial and rural areas, the top of pipe for water mains is 750mm (minimum) and 1000mm (maximum) below the finished surface;
- d) Under carriageways, the top of pipe is 750mm (minimum) and 1000mm (maximum) below finished surface level, measured at the lowest point of the carriageway;
- e) The sections of watermain adjacent to a driveway/vehicle crossing will be gradually deepened, to allow the specified cover under the driveway/vehicle crossing without the provision of vertical bends. Similar provision will be made to give the specified cover over valve and hydrant spindles;
- f) In berms, service connection pipes will have a minimum cover of 350mm and maximum cover of 500mm. In the carriageway, right-of-way or accessway, service connection pipes will have a minimum cover of 450mm and maximum cover of 750mm. At the meter box or rider main valve, the pipe is permitted to have lesser cover where it is raised to suit the fitting height.

7.3.11.2 Council will not accept public water supply pipes located through private property within the urban area.

7.3.11.3 Rural pipelines crossing private property may be permitted if no other reasonable routes are available. All new pipework crossing private property must be protected with a three-metre-wide easement-in-gross in favour of Council.

7.3.11.4 Building over or alongside a Public Watermain

- a) Buildings over any water reticulation are not permitted;
- b) Buildings alongside (within 1.5m) of any water reticulation will require a specific foundation design to be submitted to the Engineering Manager for written approval.

7.3.12 Level of Service

- 7.3.12.1 Council may require water mains or water supply facilities to be installed to a higher specification (capacity or strength) to provide for future development.
- 7.3.12.2 The Council's reticulation and asset plans should be carefully referred to when designing extensions to, or amendments to the existing water supply reticulation.
- 7.3.12.3 Regarding supply requirements, Council, at its discretion may require demonstration of compliance for normal demand, or to a nominated higher standard.
- 7.3.12.4 For commercial or industrial development, network design should be determined by normal demand flows or fire-fighting flows and the Designer must demonstrate analysis of both scenarios.
- 7.3.12.5 The Council may provide details of the working pressure or pressures at the point or points of connection to the existing reticulation that may be used for design purposes.

7.3.13 Water Pressure and Storage Requirements

- 7.3.13.1 Table 7-4 summarises the more general requirements of the Code of Practice for Normal Reticulation Design. Further specific reference to the requirements Code of Practice may be required for unusual situations.

Table 7-4 SNZ PAS 4509 Fire Fighting Flow, Pressure and Storage Requirements

Fire water class	Reticulated Water Supply				Non-reticulated water supply	
	Hydrant flow required within a distance of 135m (l/s)	Additional Hydrant flow required within a distance of 270m (l/s)	Maximum number of fire hydrants to provide flow	Residual water pressure at hydrants	Time (fire-fighting) (min)	Volume (m ³)
FW1	7.5	-	1	100 kPa	15	7
FW2	12.5	12.5	2	100 kPa	30	45
FW3	25	25	3	100 kPa	60	180
FW4	50	50	4	100 kPa	90	540
FW5	75	75	6	100 kPa	120	1080

Note: See the Fire-Fighting Code of Practice for additional notes and other specific requirements.

7.4 Pipe Specifications

This section sets out Council's expectations for pipes, including general specifications, materials, sizes, joints and seismic and liquefaction standards.

Mandatory Matters

Council requires the following standards to be met in determining pipe design and materials choices:

7.4.1 Pipe Size

- 7.4.1.1 Table 7-5 sets out the general pipe size, material, and pressure specifications for principal and rider mains.

Table 7-5 General Pipe Specifications

	Principal Mains	Rider Mains
Pipe Size	Generally, not less than 150mm nominal ID Standard pipe sizes (see Section 7.3.5 - Design): DN 100 (with specific approval), DN 150, 200, 250, 300, 375, 450, 525 and 575mm nominal ID	Not less than DN 63 (50mm nominal ID)
Acceptable Materials and Specification	PVC-U or (Series 1 or Series 2 dimensions) PVC-M Series 1 or Series 2 or PVC-O (with specific approval) PE 80 (MDPE) (with specific approval) PE100 (with specific approval) Concrete lined steel (arc butt welded) Concrete Lined Ductile iron Hobas GRP (with specific approval)	PE 80 (MDPE), PN12.5 or PE100 PN16 PVC-U (DN 50mm internal diameter only Series 1 dimensions, not less than PN15) MDPE (must be used for valve upstands, see SD 707)
Pressure class	No less than PN12 A higher class will be required in higher pressure zones.	
Pipe colour	To suit purpose	

Notes:

- 1) PVC and PE pressure pipes in New Zealand and Australia are usually referred to by their nominal diameter or “DN”;
- 2) By Convention, PVC pipes, steel, and ductile iron pipes are referred to by their nominal INTERNAL diameter (i.e. DN50, 100, 150 etc) and either Series 1 (metric sizes) or Series 2 (Imperial or CIOD sizes);
- 3) PE pipes are usually referred to and specified by their nominal OUTSIDE diameter (i.e. DN 63, 125, 180mm OD etc);
- 4) DN 63 = 50mm nominal internal diameter, DN 125 = 100mm nominal internal diameter, DN 180 = 150mm nominal internal diameter;
- 5) In any instance where an external diameter is shown on a drawing or specified it will be annotated “OD”. Dimensions in absence of either “ID” or “OD” will be assumed by Council to refer to a nominal internal diameter (“ID”);
- 6) Minimum and standard pipe sizes for principal and rider mains are shown in Table 7-5;
- 7) PVC pipes should generally be specified in metric (Series 1) sizes, but imperial (series 2) sizes may be required in some instances for specific pipelines to achieve compatibility with Council’s existing pipe system. Series 1 (metric) sizes or Series 2 (imperial) sizes are listed in the relevant PVC pipe manufacturing standards.

7.4.2 Pipe Materials

7.4.2.1 PVC-U or pipes are acceptable in all normal circumstances for principal mains.

7.4.2.2 PVC-M or PVC-O pipes may be approved on application. Installation will be to AS/NZS 2032 and AS/NZS 2566 Part 2, with particular attention to the anchoring of valves and hydrants against displacement in operation. Refer SD 703 and 704 and NZS 4404, Appendix A “Acceptable Pipe Materials”.

- 7.4.2.3 PE or PVC pipes will be used in all rider mains.
- 7.4.2.4 All PE pipes will be produced from PE compound complying with AS/NZS 4130 and PIPA Technical Specifications POP 004 (polyethylene pipe and fittings compounds).
- 7.4.2.5 PE pipes will require specific approval by the Engineering Manager. For PE pipes PE80 PN12.5 material is the standard used. PE100 PN16 may be required in high pressure areas. For PE pipes DN 125 and larger, PE 100 is the Standard used.
- 7.4.2.6 Pipes of differing compositions will not be mixed within a common pipe length, (i.e. valve-to-valve). Installation of PE pipes will be to AS/NZS 2033 and AS/NZS 2566 Part 2.
- 7.4.2.7 Concrete lined steel pipes that are required in potentially unstable ground, for lengths of exposed pipe, or in other special cases, will be the subject of specific design. Suitable corrosion protection will be provided. Steel pipes laid underground will have an extruded blue or black HDPE external coating. Pipe laid above ground will have a black HDPE coating or will have an approved epoxy coating applied by a specialist applicator.
- 7.4.2.8 Ductile iron pipes will require specific approval of Council. Ductile iron pipes will be sleeved with a polyethylene sleeve, conforming to AS 3681.
- 7.4.2.9 PE100 may be used where higher pipe strength or higher-pressure class is required or increased capacity is an important criterion.

7.4.3 Pipe Joints

- 7.4.3.1 Where a rider main is to be extended at right angles to a principal main, an elongated gibault will be used (see SD705).
- 7.4.3.2 Where a rider main is to be extended along the same alignment beyond the end of the principal main, it will normally be connected in accordance with SD706.

7.4.4 Unrestrained Mechanical Couplings

- 7.4.4.1 Old style 'Gibault' joints have been superseded by new "universal" design bolted unrestrained mechanical couplings, conforming to AS/NZS 4998, for all pipes except PE where only end load restraint compression fittings, or heat fusion fittings, conforming to AS/NZS 4129, will be used.
- 7.4.4.2 Unrestrained Mechanical Couplings will be category 2 (50-year life) to AS/NZS 4998:2009.

7.4.5 PVC Pipe Joints

- 7.4.5.1 Joints for PVC pipes will be integral thermoformed socket/spigot rubber ring type (Z joints or locked-in-place Blueseal/Forsheda/Reiber style), with a biocidal lubricant. Elastomeric seal rings will conform to AS 1646.
- 7.4.5.2 Unrestrained Mechanical Couplings (repair couplings) will only be used to close a section of pipe where no other fittings are possible, or to adapt PVC pipe to existing in situ pipes, such as cast iron, asbestos cement, steel or ductile iron, or to connect PVC pipe to a purpose made ductile iron spigoted fitting.
- 7.4.5.3 Solvent cement joints on reticulation will not be permitted without the written approval of the Engineering Manager.

7.4.6 PE Pipe Joints

- 7.4.6.1 All PE pipe less than or equal to DN63 (50mm OD) will be joined by end load restraint mechanical seal ring compression joints to AS/NZS 4129, appropriate for the type of pipe (e.g. “Plasson, “Philmac”) and rated to PN16 maximum working pressure.
- 7.4.6.2 All PE pipes DN125 (100 mm ID) or larger will be joined by butt-fusion joints or electrofusion fittings conforming to AS/NZS 4129.
- 7.4.6.3 Butt-fusion joints will comply with PIPA Technical Specification POP 003 (Butt Fusion Jointing of PE Pipes and Fittings – Recommended Parameters).
- 7.4.6.4 Electrofusion joints will comply with POP 001 (Electrofusion Jointing of PE Pipes and Fittings for Pressure Applications).
- 7.4.6.5 PE pipes will be installed in accordance with AS/NZS 2033 and AS/NZS 2566.
- 7.4.6.6 Certified tradespersons (as required in 7.4.6.8) approved by Council, will be employed with semiautomatic or fully automatic welding equipment specifically designed for the task.
- 7.4.6.7 All butt welding or electrofusion welding equipment must be data log capable and all log information must be made available to Council on request. The contractor will provide their own power source and earth leakage protection for the safety of their personnel. No manual welding of pipe joints will be accepted.
- 7.4.6.8 For electrofusion and butt welding, only personnel trained and holding a current certificate of competency in the system to be used, will be permitted by Council to carry out the work. A copy of the current certificate must be provided to Council before any welding proceeds.
- 7.4.6.9 The use of electrofusion joints on HDPE pipes is a specific task that requires special adherence to quality materials and certified equipment, a clean and dry site and electrofusion jointing qualified personnel. NZS 4130 generally outlines Polyethylene Pressure pipes criteria and the TEPPFA Technical Guidance document - AGU/2014/01 (A good practice guide for the electrofusion jointing of larger diameter polyethylene and pressure pipes).

7.4.7 Welded Steel Pipe Joints

- 7.4.7.1 Welded joints in steel pipes will be either butt joints or full penetration butt weld with an external welding band or bevelled. All welds will be fillet welds of 7mm or larger, applied in the field. All welding is to be undertaken by certified personnel approved by Council. A copy of the current certificate must be provided to Council before any welding proceeds.
- 7.4.7.2 Flange joints will be to AS 4087.
- 7.4.7.3 Where butt jointed pipes are used, the ends will be neatly butted where possible with a seal weld applied from the outside before the welding band is affixed. Steel pipes will be cut to a neat and true line with an abrasive saw.
- 7.4.7.4 After welding and testing (if required) all unprotected metal inside and outside will be thoroughly cleaned by appropriate methods.
- 7.4.7.5 The exposed steel will be protected promptly, and damaged protective coating repaired in an approved manner by the application of one of the treatments listed below:

- a) Emer-tan rust converter; Emer-guard primer; Emer-clad membrane; or
- b) Polyken Synergy™ which includes an appropriate primer coat; or
- c) Carbomastic 15 primer; Servi-Wrap R15A membrane; Servi-Wrap Outerwrap.

7.4.7.6 Joints will be internally protected with a mortar lining to give a smooth internal bore. Materials for the mortar will comply with the requirements of NZS 3121. It is important to get a satisfactory mortar consistency to prevent the mortar from sagging or dropping out.

7.4.7.7 The pipe joint will be plugged with a suitable plunger prior to applying the mortar and then withdrawn evenly to smooth out the mortar joint.

7.4.7.8 Epoxy mortar (suitable with potable water) will be used for making good the mortar lining where pipes have been cut for mitred joints, or the fitting of flanges etc.

7.4.8 Seismic Design for Pipes

7.4.8.1 All pipes and structure will be designed with adequate flexibility and special provisions to minimise risk of damage during earthquakes.

7.4.8.2 Historical experience in New Zealand earthquake events suggests that suitable pipe options, in seismically active areas, may include rubber ring joint PVC pipes, or PE pipes. Specially designed flexible joints will be provided at all junctions between pipes and rigid structures (such as reservoirs, pump stations, bridges, and buildings) in natural or made ground.

7.4.8.3 In areas prone to liquefaction or lateral spread, a geotechnical investigation will be required. The geotechnical investigation will need to assess the potential of the ground to liquefy under seismic loading and assess the likely effects of liquefaction on buried infrastructure. The assessment will be conducted in accordance with NZGS guidance: Guideline for the identification, assessment and mitigation of liquefaction hazards.

7.4.8.4 In areas where there is a potential for liquefaction or lateral spread to impact on buried infrastructure, the network must be designed with special provisions to minimise the risk of damage during an earthquake. Piped infrastructure is not generally designed for a particular seismic event but rather for optimum resilience under seismic loading.

7.4.8.5 All PE pipes will be jointed using butt welding or electrofusion technique. Electrofusion fittings will conform to AS/NZS 4129.

7.4.9 Watermains in Hydrocarbon Contaminated Ground

7.4.9.1 PVC pipes with EPDM or nitrile seal rings or solvent cement joints may be used in hydrocarbon contaminated ground.

7.4.9.2 PE pipes will not be used in ground that has been contaminated with hydrocarbons.

7.5 Fittings

This section sets out Council's requirements for pipe fittings, hydrants and valves.

Mandatory Matters

Council requires the following standards to be met in the choice and design of water supply fittings:

7.5.1 Pipe Fittings

- 7.5.1.1 Ductile iron fittings such as tees, hydrant tees, crosses, tapers, hydrant risers, blank caps, plugs and bends will conform to AS/NZS 2280, with thermo-bonded polymeric coating conforming to AS/NZS 4158. Ductile iron sockets for Elastomeric seal joints, used with PVC pipes will be “deep socket” type.
- 7.5.1.2 Tapping bands used on PVC pipes will be “full encirclement style” conforming to AS/NZS 4793.
- 7.5.1.3 Thermoformed PVC, elastomeric socket, long radius bends may be used with PVC pipes. and short radius (elbow) bends will not be used. Solvent cement bends may only be permitted where the necessary Z ring fitting is not manufactured.
- 7.5.1.4 On PE pipes DN 125 and larger, fittings will be end load resistant electrofusion or butt fusion style, to AS/NZS 4129.
- 7.5.1.5 Flanges will be to Table 9 of AS/NZS 4331.2 and AS/NZS 4087. Fittings laid adjacent to other fittings will have flanges.
- 7.5.1.6 All bolts, nuts and washers will be 316 stainless steel with molybond anti galling coating.
- 7.5.1.7 Graphite greases, packing and compounds will not be used in contact with stainless steel.
- 7.5.1.8 Where dissimilar metals are used, purpose-made delrin thermoplastic inserts will be installed in the flanges to prevent electrolytic action.
- 7.5.1.9 Fittings which do not have bolts, nuts and washers which are 316 stainless steel and/or fittings which are not thermos-bonded polymeric coated in accordance with AS/NZS 4158, will only be used at the Engineering Manager’s discretion where no alternative product is available. In this case these fittings will be wrapped as detailed in SD707 and SD708.

7.5.2 Corrosion Protection

- 7.5.2.1 These standards apply to the protection of flange and unrestrained mechanical couplings.
- 7.5.2.2 Protection will normally be provided by the use of 316 stainless steel bolts, nuts and washers and fittings coated to AS/NZS 4158. Fittings which do not have bolts, nuts, and washers that are 316 stainless steel and/or fittings which are not thermos-bonded polymeric coated will only be used with approval of the Engineering Manager.
- 7.5.2.3 Where metallic pipes and fittings are not coated Delrin thermoplastic inserts will be installed in the flange to prevent electrolytic action. Steel, grey cast iron and ductile iron flanges will be further protected by a wrapping system.
- 7.5.2.4 Corrosion protection will be required (as follows) for all new flange and unrestrained mechanical couplings, where materials other than 316 stainless steel and coatings to AS/NZS 4158 are used.
- 7.5.2.5 Flanges will comply with SD707.
- 7.5.2.6 Unrestrained Mechanical Couplings will comply with SD711 and AS/NZS 4998.

7.5.3 Hydrants

- 7.5.3.1 Fire hydrants will be installed on all principal mains in accordance with the requirements of the New Zealand Fire Service Code of Practice.
- 7.5.3.2 Hydrants must be readily accessible for fire appliances and should generally be positioned near road/street intersections in conjunction with valves.
- 7.5.3.3 A fire hydrant will be located at each road/street intersection and not be positioned closer than 6.0m from any dwelling.
- 7.5.3.4 In a cul-de-sac or other terminal streets, the last hydrant will be at the head of the cul-de-sac.
- 7.5.3.5 The distance between the hydrants and from the hydrants to the furthest building platform will not exceed 135.0m.
- 7.5.3.6 Should a fire hydrant be required to be provided on private rights-of-way, Engineering Manager's approval will be required. Council will require either an Easement In Gross in favour of Council over that line from the principal main to the hydrant or leave it as a private asset and have an isolation valve at the boundary.
- 7.5.3.7 Hydrants will be to NZS 4522. Normally the short pattern will be used, except where Council may approve or require the medium or tall pattern for extra flow capacity. Hydrants will not be self-draining. Hydrants will be blue nylon coated inside and out and be clockwise closing.
- 7.5.3.8 In some high-risk commercial areas, hydrants will be installed in pairs to provide better water flows (also refer Table 7-5).
- 7.5.3.9 Hydrant tees will be flanged if laid next to other fittings. Otherwise flexible Z ring joints are permitted, refer SD703.
- 7.5.3.10 Hydrant risers will be used or the water main laid deeper where necessary, in order to ensure that the top of the spindle is between 100mm and 200mm below finished surface level.
- 7.5.3.11 Hydrants will be installed so the spindle cap and riser connection are in line with the water main below.
- 7.5.3.12 The manufacture and installation of hydrant boxes will be to NZS 4522. Hydrant boxes will be aligned in the direction of the water main. Heavy pattern hydrant boxes will be used. All hydrant boxes (cover and frame) will meet Class D strength to AS 3996. Covers must be 'anti-rocking'.
- 7.5.3.13 Hydrants will be marked in accordance with SNZ PAS 4509 Appendix G. Hydrants will be marked in accordance with NZS 4501 with raised blue reflectorised markers together with painted triangle and painted fire hydrant box as shown on SD709.
- 7.5.3.14 Hydrant boxes will be set on approved pre-cast concrete sections.
- 7.5.3.15 The top of any surface box will be flush with the finished surface level in sealed carriageway and grassed surfaces. For areas to be planted, the top of the surface box will be between 40mm and 60mm above the finished surface level and no closer than 1.5m to trees or shrubs.

7.5.4 Positioning of Valves

- 7.5.4.1 Valves will generally be placed on all the three legs of a tee intersection to optimise control of the water supply system and minimise the number of customers without water in case of a shut-down.
- 7.5.4.2 Sluice valves will be flanged and bolted to each leg of the “tee” to form a single assembly. A hydrant will be included between the valves.
- 7.5.4.3 Line valves will be installed where the distance between other line valves exceeds 250m. For water mains over 200mm diameter, line valves will be required at least every 450m and will be positioned as agreed by Council. Rider mains will have valves at both ends, located as close to the principal main as practical, but within the berm or footpath.

7.5.5 Depth of Valves

- 7.5.5.1 The top of sluice valve spindles will be 200-300mm below ground level, refer SD704.
- 7.5.5.2 The top of the hand wheel on any resilient seated valve will be 150 to 225mm below ground level.

7.5.6 Sluice Valves

- 7.5.6.1 Sluice valves on all water reticulation will comply with NZS/AS 2638.2, Class PN16 (a class higher than 16 may be required in certain circumstances).
- 7.5.6.2 Valves will be resilient, seated, and anti-clockwise closing with a stem sealed by “o” rings capable of being replaced under pressure. They will have external and internal polymeric coating to AS/NZS 4158.
- 7.5.6.3 Specific design, subject to the approval of Council, will be required for valves over 250mm NB.
- 7.5.6.4 The valve will be capable of bi-directional flow of water. Valves will be set so that the spindle is truly vertical.
- 7.5.6.5 Sluice valves will be installed in accordance with SD704 and will be marked as per SD709.
- 7.5.6.6 Approval of any particular sluice or gate valve will be entirely at the discretion of the Engineering Manager.

7.5.7 Rider Main Valves

- 7.5.7.1 Valves on rider mains of 50mm internal diameter will be an approved resilient-seated sluice valve with socket ends. Where a valve is to be connected directly to a Tee, or similar flanged item, a valve with one flanged and one socket end is to be used.
- 7.5.7.2 Valves on other than PE rider mains of 50mm internal diameter will have connections suitable for the material used – socket/thread or flange as appropriate.

7.5.8 Air Release Valves

- 7.5.8.1 Water mains will be laid to grade such that, for the purpose of the release of the air, a fire hydrant, an automatic air valve or a 20mm diameter ferrule and gate valve in a permanent surface box will be installed at high points or in locations required by Council. They will be installed so that ground water cannot enter the main at negative main pressure.

7.5.8.2 Automatic air valves >25mm, will be approved testable, single or double, large or small orifice, and of appropriate nominal bore. Automatic air valves will be flanged and be mounted on flanged risers with an integral isolating valve accessible from ground level. Air valves that need to be installed below ground will be installed within a standard manhole (marked 'AV) with positive drainage to an outlet such that ground water cannot enter the main at negative mains pressure.

7.5.8.3 Automatic air valves should be installed above ground in all situations unless approved by the Engineering Manager.

7.5.9 Scour Valves

7.5.9.1 Scour valves will be either a fire hydrant or an approved resilient seated valve as for air release above and will be installed at low points or to facilitate draining of a water main where required by Council.

7.5.9.2 All dead-end mains or rider mains will be fitted with permanent scour valves complete with valve box.

7.5.9.3 In areas where the scouring of mains is needed as a frequent operation, a connection to an approved discharge point will be provided. The connection of a scour valve to stormwater pipes or manholes is not permitted.

7.5.9.4 The box will be similar to a fire hydrant box but will be marked "SV" rather than "FH".

7.5.10 Butterfly Valves

7.5.10.1 Butterfly valves will only be used with the specific approval of the Engineering Manager.

7.5.10.2 Butterfly valves will be located in concrete valve chambers.

7.5.11 Non-Testable Non-Return Valves

7.5.11.1 Swing check valves will comply with the relevant standards and AS 4794-2001.

7.5.11.2 Non-return valves will be capable of being serviced without removal from the main. Cast iron swing check valves will be fusion bonded thermoplastic coated or epoxy coated. All coatings will be compatible with potable water and will be coloured blue.

7.5.11.3 Below ground swing check valves will be within a standard manhole.

7.5.12 Valve Boxes

7.5.12.1 All valves will be fitted with an approved square pattern cast iron surface box with the lid marked "SV" or "V" and a 150mm lid on a PVC riser pipe. Heavy duty lids will be used.

7.5.12.2 The riser pipe will extend from the valve bonnet to 80mm below the finished surface and be placed vertically over the valve. The valve box will be supported on a firm foundation so that no direct loading is transmitted from the box to the main or riser, see SD703

7.5.12.3 If the distance between the finished surface level and the top of the valve spindle is greater than 300mm, a valve key extension will be fitted.

7.5.12.4 Valve boxes will be painted as shown in SD709.

7.5.13 Restraint blocks

- 7.5.13.1 Cast in-situ concrete restraint blocks will be provided on mains 50mm ID or greater, at all points where an unbalanced thrust occurs. This will include all bends, tapers, valves, pressure reducing valves, tees and blank ends.
- 7.5.13.2 For butt welded and electrofused PE pipework up to 150mm ID, restraint blocks may not be required. Where PE pipes connect to other pipework or fittings with flexible joints, restraint blocks are required.
- 7.5.13.3 The design of restraint blocks will be based on “good ground” soil bearing capacity (as defined in NZS3604) or the ultimate bearing capacity of the site soils, whichever is lesser. A safety factor of between 1.5 and 2 will be used in the design. Restraint block bearing area calculations will be submitted with the engineering plans for checking and approval.
- 7.5.13.4 The inner face of the block will not be of a lesser thickness than the diameter of the fittings and will be so constructed as not to impair access to the bolts on the fittings. Concrete will have a minimum compressive strength of 25mPa at 28 days.
- 7.5.13.5 All restraint blocks will be cast in-situ concrete. Pre-cast concrete blocks may be permitted with the Engineering Manager approval.
- 7.5.13.6 A protective membrane of not less than three layers of 250 micron polythene sheet or similar will be provided between the pipe (irrespective of the pipe material) and the concrete block to prevent abrasive damage to the water main.
- 7.5.13.7 Valves and hydrants on PVC pipe lines require anchorage to resist torque when the valve is operated.
- 7.5.13.8 Valves will be anchored as shown on SD704. A fish-tailed galvanised flat steel bar will be attached to the bottom bolt on each flange of the valve and incorporated into a cast in-situ concrete pad 200mm deep, of the same width as the trench and extending 150mm beyond each anchor bar. Care will be taken to ensure that all bolts can be removed for future maintenance and are not obstructed by concrete.
- 7.5.13.9 Hydrant tees, when flanged, will be anchored as valves, refer SD704. Hydrant tees with rubber ring joints will be anchored by bedding the tee in a concrete pad 200mm deep, of the same width as the trench and not extending beyond the length of the tee. Care will be taken to ensure that the flexible joints are not encased.

7.5.14 Thrust Block design

- 7.5.14.1 In designing water main restraint blocks, the following formula will be used:

Bends:

$$\text{Thrust Force } R = 15.4 H d^2 \sin(\theta/2)$$

R = thrust in kN

Where H = head of water in metres, i.e. 180m max

d = diameter of pipe in metres

θ = angle of deflection Pipe dia - d	θ -11.25° bend	θ -22.5° bend	θ -45° bend	θ -90° bend
100	2.77	5.51	10.81	19.98
150	6.23	12.40	24.33	44.96
200	11.08	22.05	43.26	79.93

R – thrust in kN for each diameter and bend.

Tee or Closed End:

$$\text{Thrust Force } R = 7.7 H d^2$$

R = thrust in kN

Where H = head of water in metres, i.e. 180m max

d = diameter of pipe in mm

Reducers:

$$\text{Thrust Force } R = 7.7 (d_1^2 - d_2^2)$$

R = thrust in kN

Where H = head of water in metres, i.e. 180m max

d1 and d2 are the two pipe internal diameters in mm. The magnitude of this thrust can be obtained by taking the difference of the two thrusts for closed ends of the two relevant diameters.

Table 7-6 Pipe Thrust Block Design

	Pipe diameter	Face area m2 or m3	11.25° Angle of deflection	22.5° Angle of deflection	45° Angle of deflection	90° Angle of deflection
Vertical downward thrust	100	m2	0.09*	0.09*	0.09*	0.13
	150	m2	0.09*	0.09*	0.16	0.30
	200	m2	0.09*	0.15	0.29	0.53
Vertical upward thrust	100	m3	0.17	0.34	0.68	1.25
	150	m3	0.39	0.74	1.52	2.81
	200	m3	0.69	1.34	2.70	5.00
Horizontal sideways thrust	100	m2	0.12	0.23	0.45	0.83
	150	m2	0.26	0.52	1.02	1.88
	200	m2	0.46	0.92	1.81	3.34

Note:

- 1) *Minimum restraint block size 300 x 300 x 300;
- 2) Table 7-6 is a guide only;
- 3) Soil parameters are classed as “good ground” in accordance with NZS 3604;

- 4) Test head 150m and factor of safety of two (2) for all applications.

7.6 Water Supply Connections

This section prescribes standards for the provision of supply connections.

Mandatory Matters

Council requires the following standards to be met in the provision of supply connections

7.6.1 Point of supply to customer

- 7.6.1.1 The point of supply to each customer will be determined in accordance with the Council's Water Supply Bylaw. Each individual dwelling or unit will have a single point of water supply and a meter. Premises of multiple ownership including body corporate, strata title and leasehold/tenancy in common scheme will be supplied and metered in accordance with the Council's Water Supply Bylaw.
- 7.6.1.2 Individual lots will have individual meters located at the street boundary. From the meter an individual water connection will be installed to the body of each individual lot.
- 7.6.1.3 In all situations the meter box is to be located a minimum of 0.5 m clear of the driveway entrance and not located within the driveway.

7.6.2 Service Connection Diameter

- 7.6.2.1 The standard connection sizes must be 20mm ID, 25mm ID, 40mm ID, 50mm ID, 100mm ID and 150mm ID. Any connection larger than this will need to be approved by the Engineering Manager.
- 7.6.2.2 The minimum size will be 20mm internal diameter to urban connections.
- 7.6.2.3 The minimum size connection to a commercial/industrial lot is 50mm internal diameter.

7.6.3 Individual Connections

- 7.6.3.1 An individual connection will be required for each lot via its own legal street frontage with the meter assembly located at the street boundary. For clarification - back sections served by rights of way need to have their own individual water meter located at the street frontage. Individual water connections (owner and maintained by the individual land owners) are to be provided from the meter to the rear lots.
- 7.6.3.2 Where tapping bands and service connections are to be omitted in commercial and industrial subdivisions (with the approval of the Engineering Manager), a covenant will be placed on the title outlining that the lot owner is responsible for all costs associated with the installation of the service connection (all costs include development contributions physical installation and related fees).
- 7.6.3.3 All service connections will be laid at right angles to the frontage. The supply line between the ferrule and the meter box is to be laid as a single length of pipe with no joins or tight bends along its length.

7.6.4 Tapping Bands and Ferrules

- 7.6.4.1 Tapping bands for PVC pipes will comply with AS/NZS4793.

- 7.6.4.2 Tapping bands for PE pipes will be specifically designed for use with PE pipe and comply with AS/NZS 4129. Bronze mechanical tapping saddles will not be used on PE pipes.
- 7.6.4.3 Where the horizontal distance between the ferrule and the meter manifold is less than 1.0m, the assembly will be subject to specific design approval by the Engineering Manager and will be laid to avoid any pipe stresses.
- 7.6.4.4 In all situations, lateral connections and ferrules will be located a minimum of 0.5m clear of driveway entrances.
- 7.6.4.5 Each service connection to a main or a rider main will be by means of a tapping band and a "Talbot" Bronze push-fit swivel ferrule with the flow of water controlled by a screwed brass plug.
- 7.6.4.6 Tapping bands on PVC pipes will be of an approved type complying with AS/NZS 4793, fully encircling the pipe to prevent over tightening and distortion of the pipe.
- 7.6.4.7 Tappings on ISO dimension PE80 - pipes will be by means of a vertical compression tee (with BSP female branch) and ferrule. Tapping saddles will not be used on PE pipe without approval by the Engineering Manager.
- 7.6.4.8 If the required service is larger than is possible to connect with a tapping band the main connection will be by a tee or a tapped elongated joint having a vertically connected ferrule. For connections, larger than 50mm ID, the connection will be by means of an elongated gibault tee and sluice valve at the approval of the Engineering Manager.
- 7.6.4.9 Tapping bands and ferrules on the water mains will be fitted when the mains are first laid (except as provided for in Section 7.6.4).

7.6.5 Meter Assembly for 20mm and 25mm ID Connection

- 7.6.5.1 The service connection will terminate adjacent to the street boundary with an approved 20/25mm nominal bore water meter assembly and box approved by the Engineering Manager. All meter assemblies must consist of a manifold, isolating valve and double check valve housed in an "Everhard", Acuflo AMBT285, or "Draper" DRA 20/1 underground meter box. Metal meter boxes are to be used for commercial and industrial accessways and in residential areas that will be traffic loaded and with the approval of the Engineering Manager.
- 7.6.5.2 The meter box will be no closer than 150mm or more than 300mm away from the street boundary on the street side of the boundary, clear of regular vehicle traffic movement.
- 7.6.5.3 The pipework at the meter box will have an earth cover of 260mm to 300mm depth over it. Refer SD706 and finished flush with the surrounding ground.
- 7.6.5.4 The meter box will be placed on a firm base so that it will not be depressed below the finished surface by settlement or occasional vehicular traffic.

7.6.6 Meter Assembly for 32 - 40mm ID Connection

- 7.6.6.1 For 32 – 40mm ID services a meter assembly consisting of an approved resilient seated valve with stainless steel bolts will be used. The meter will be approved by the Engineering Manager. An approved backflow preventer will be used with the meter and housed in an approved meter box or above ground if testable.

7.6.7 Meter assembly for 50mm ID and larger Connection

7.6.7.1 All service connections including dedicated fire sprinkler or fire-fighting mains will be required to be metered.

7.6.7.2 The meter will be a compound meter and will be approved by the Engineering Manager and will be installed at the boundary to the manufacturer's specification and housed along with approved isolating valve and backflow preventer in a meter box of size and construction approved by the Council. If a reduced pressure zone backflow preventer is used, this will be mounted above ground level. Meters other than compound meters require specific approval for installation at new sites.

7.6.8 Water Meters

7.6.8.1 At the completion of works and prior to issue of the 224 certificate for developments, the Developer must supply a completed water meter location form (see Appendix A) to the Engineering Manager for approval. Water meters will be fitted to all connections in accordance with Table 7-7.

Table 7-7 Approved Water Meters and Meter Boxes

Connection Size, ID (DN) (mm)	Meter Size (mm)	Meter Designation	Average Flow (m ³ /hr)	Maximum flow (m ³ /hr)	Meter Class	Meter Type	Meter Model
20 (25)	20	Qn 1.5	1.5	3.0	Q ₃ 2.5 R160 (C)	Manifold	Must be approved by the Engineering Manager
25 (32)	20	Qn 1.5	1.5	3.0	Q ₃ 2.5 R160 (C)	Manifold	
25 (32)	25	Qn 3.5	3.5	7.0	Q ₃ 6.3 R160 (C)	In line	
40 (50)	40	Qn 15	15	45	Q ₃ 25 R315 (C)	In line	
50 (63)	50	Qn 15	30/35	50	Q ₃ 25 R315 (B/C*)	Compound	
100	80	Qn 40	40	80	Q ₃ 63 R315 (B/C*)	Compound	
	100	Qn 60	60	120	Q ₃ 100 R315 B/C*	Compound	
150	100	Qn 60	60	120	Q ₃ 100 R315 B/C*	Compound	
	150	Qn 150	150	300	Q ₃ 250 R315 B/C*	Compound	

* = for compound meters; high flow meters Class B, low flow meters Class C;

Note:

- 1) Meters with higher "R" numbers are acceptable. Compound meters are designated by the characteristic of the larger meter only;

- 2) Meter connections larger than 25 mm diameter will be subject to the approval of the Council. The applicant may be required to present hydraulic calculations supporting the choice of meter size to the Council for approval.

7.6.9 Backflow Preventers

- 7.6.9.1 All new industrial and commercial properties will have a backflow preventer installed after the meter as close as practical to the point of supply. The type and location of backflow preventers will comply with the Building Act, the Health Act 1956 as amended by the Health (Drinking Water) Amendment Act, AS/NZS 2845.1 and the Council's Water Supply Bylaw.

7.6.10 Reuse of Existing Service Connections

- 7.6.10.1 A proposal to reuse an existing service will only be approved if the service is of adequate size; and, it can be established that the service is less than 15 years old; or, the service is to continue supplying the same building that it was originally intended for, and no others.
- 7.6.10.2 This policy applies only to the Council portion of the water service i.e. from the main up to the point of supply.

7.6.11 Disconnections

- 7.6.11.1 Redundant services will be disconnected from the water main by Council's approved contractor.
- 7.6.11.2 The service fitting will be removed or plugged at the connection to the water main.
- 7.6.11.3 All costs associated with the disconnection will be recovered by Council from the landowner requiring the disconnection.
- 7.6.11.4 Meter box, manifold assembly and meter will be removed. These remain the property of Council.
- 7.6.11.5 A final meter reading will be recorded and supplied to Council.

7.6.12 Fire Sprinkler Supply

- 7.6.12.1 A domestic fire sprinkler supply will come off the Individual water supply after the Council's water meter assembly, see SD706.
- 7.6.12.2 Commercial fire sprinklers systems will require specific design and require a separate metered connection. All above ground valves will be suitably protected from vandalism or accidental damage.
- 7.6.12.3 Designs for fire sprinkler and reticulation will allow for pressure reductions due to backflow prevention devices.
- 7.6.12.4 Fire sprinkler supply connections may require combination metering.
- 7.6.12.5 Fire sprinkler system as a means of compliance with the New Zealand Fire Service Fire Fighting Water Supplies Code of Practice will require a Notice to be registered on the land title setting out the requirements of the landowner for ongoing maintenance of the system and a condition entered in the Council's database accordingly.
- 7.6.12.6 Council's compliance with the code of practice relating to fire-fighting is detailed in section 7.3.9.

Good Practice

The following matters provide additional direction and guidance in the design of supply connections:

7.6.13 General

7.6.13.1 Regarding service connection materials, ISO dimension PE80 pipes to NZS 4130 are normally technically adequate.

7.6.13.2 Council does not allow the use of copper pipe.

7.7 Pumping and Storage

This section deals with standards and good practice matters relating to pumping and storage aspects of the water supply network.

Mandatory Matters

Council requires the following standards to be met in the design of pumping and storage solutions:

7.7.1 Pump Station Design

7.7.1.1 Pump stations will comply with Council's requirements and these specific designs are updated on a regular basis. Design will be dependent on a number of factors and should be discussed with the Council at an early stage.

7.7.1.2 New pumping stations will only be accepted by Council when all other practical options have been ruled out.

7.7.1.3 Design of the pumping station will enable operation of the station in compliance with industry health and safety requirements having particular regard to safety from falling aspects on site and confined space entry.

7.7.1.4 In all pumping stations, the following design specifications apply:

- a) Sufficient duty pumping capacity will be available to handle the design peak flow within a pumping period of 12–15 hours;
- b) A minimum of two pumps will be installed, with one acting as duty pump and the other on automatic standby. The duty sequence is to be alternate start on variable speed drives in accordance with Council control system standards. The standby pump will be equal in capacity to the duty pump;
- c) Ground floor levels will be at least 200mm above finished ground levels in order to exclude surface water entry;
- d) All pump station site structures will be designed for a minimum 100-year life complying with the building code;
- e) All electrical systems need to be radio frequency neutral, isolated or complying with Central Government radio frequencies standards;
- f) The structure needs to meet seismic resilience level of importance 3.

7.7.2 Access and Services

- 7.7.2.1 Pumping stations and control buildings will be sited on a separate lot or a utility reserve. The lot is to be vested in Council and will have a sealed access road for maintenance vehicles. The site as a minimum should have screen planting on all common boundaries that will not exceed 2m in height on the South boundary.
- 7.7.2.2 A means of lifting pumps and other heavy equipment, or alternatively access to enable mobile plant to perform this task is to be provided on site.
- 7.7.2.3 An approved flow meter will be installed on the outlet line from the pump station and connected to the telemetry system.

7.7.3 Electrical Equipment

- 7.7.3.1 An electrical pump control, alarm, and telemetry system is required on site. It will be assembled and installed in accordance with Council's standard specification.
- 7.7.3.2 A stainless-steel control cabinet is required to house electrical equipment. Cabinets are to be fitted with a lock keyed to Council's security system.
- 7.7.3.3 All electrical switch gear is to be located a minimum of 300mm above ground level. All electrical equipment is to be assembled and installed in accordance with these standards or the manufacturer's specifications.
- 7.7.3.4 All equipment including metering must comply with the requirements of the Network Utility operator and supplier (power).
- 7.7.3.5 Suitable alarm and system control interrogation and transmitting facilities will be provided to enable the pumping stations to be connected to Council's telemetry system.
- 7.7.3.6 Cable ducting from the pump station to the control cabinet must be sealed to protect against vermin entering the electrical switchboard.
- 7.7.3.7 All electrical and pump station control gear including telemetry will be housed within a weather proof, lockable, walk-in building to Council approval.
- 7.7.3.8 Phase failure protection relays will be provided for all pump motors unless that protection is incorporated into the electronic control for Soft Start or Variable Speed Drive units.
- 7.7.3.9 Automatic control of the pump operation, together with a manual override facility is to be provided.
- 7.7.3.10 A standard three-phase industrial power connection will be supplied such that a portable generator can be connected when power failure occurs.
- 7.7.3.11 Suitable lighting inside buildings and outside will be provided for the pump station, cabinets and valve chambers with protective materials suited to the external environment.
- 7.7.3.12 Details on pump/motor components and electrical control equipment will be incorporated into an Operation and Maintenance Instruction Manual provided in electronic format.
- 7.7.3.13 The Manual will include as-built plans of the pump station including electrical wiring and operational schematic diagrams. Electronic copies of the Manual will be supplied to Council on handover of the completed pump station and associated works.

7.7.3.14 Any digital data/ programs relating to variable speed drives and starting equipment must be given to Council digitally at the time of commissioning and included in the Operations and Maintenance manuals.

7.7.3.15 All electrical systems need to be radio frequency neutral, isolated or complying with Central Government radio frequencies standards.

7.7.4 Commissioning

7.7.4.1 On completion of any pump station, and prior to handover to Council, a full commissioning test will be carried out on all components of the pump station. This commissioning will be in the presence of a representative of Council and of Council's operations and maintenance contractor.

7.7.5 Reservoir Requirements

7.7.5.1 Small individual reservoirs are not permitted.

7.7.5.2 If a developer needs to construct a reservoir as part of a development, discussions must occur with the Engineering Manager regarding the specific needs for that catchment. This may result in the Council working with the developer to optimise the reservoir design and location.

7.7.6 Security of Water Supply Facilities

7.7.6.1 The developer will provide temporary locks on all doors, lids, chamber covers and gates that require limited access for operational or security purposes.

7.7.6.2 Appropriate locks will be ordered through Council and fitted to facilities prior to application for 224 certification. The developer will be responsible for all costs associated with the supply and fitting of locks.

7.7.6.3 Once Council locks are fitted to water supply facilities only Council or their maintenance contractor and engineering consultancy staff will have access to the equipment.

7.7.6.4 Council's maintenance contractor will assume responsibility for routine maintenance of the asset but any work arising from failure of equipment or materials, or faulty workmanship will be on-charged to the Developer during the prescribed defects maintenance or guarantee period.

7.7.7 Private Pumping Stations

7.7.7.1 Individual, private pump systems are permitted provided the design and construction meets the requirements of the NZ Building Code (a Building Consent will be required) and the connection to the Council system is via a water meter and backflow protection to a suitable sized water tank located on the private land. There is to be no direct pumping from a water connection.

7.8 Construction and Installation

This section sets out Council's expectations for the installation and construction of the water supply network.

Mandatory Matters

Council requires the following standards to be met in the construction and installation of water supply reticulation:

7.8.1 Trench Width

- 7.8.1.1 The minimum trench width will be 200mm wider either side than the external diameter of the collar of the pipe being laid.
- 7.8.1.2 The trench will be of sufficient width to permit with freedom the installation of all trench support and to allow the laying and jointing of pipes and placing of bedding and pipe surround materials.

7.8.2 Base of Excavation

- 7.8.2.1 No construction or work above the excavation base will commence until the base of the excavation has been inspected and accepted by the DPA. The trench base is to be checked for stability of the soil by the DPA.
- 7.8.2.2 The Contractor will provide trench support to comply with the requirements of Work Safe New Zealand.

7.8.3 Trench Support

- 7.8.3.1 The Contractor will ensure that the sides of the trench are sufficiently supported so that cracking of the surrounding ground does not occur.

7.8.4 Trench Foundation Stability

- 7.8.4.1 Where there are issues concerning foundation compaction and stability, the DPA will order the use of additional granular bedding material as specified in AS/NZS 3725 for concrete pipes, or AS/NZS 2566.2 for PVC and other flexible pipe systems.

7.8.5 Dewatering

- 7.8.5.1 Excavations will be kept free of water during construction.
- 7.8.5.2 In no circumstances will stormwater or ground water be allowed to drain into any existing wastewater drain.
- 7.8.5.3 Discharge of stormwater or groundwater to existing stormwater drains will be permitted providing adequate silt traps prevent debris and suspended matter from entering drains. Should deposits in existing stormwater drains or the pipes already laid occur as a result of the operations of the Developer or the Contractor such deposits will be cleared forthwith at the Developer's or the Contractor's cost as the case may be.
- 7.8.5.4 The Contractor or Developer will cause as little damage or interference to property or persons as possible in disposing of water from the works, and will be responsible for any damage or interference, which may be caused. This will include any damage to the structure of any road.

7.8.6 Metal Bedding

- 7.8.6.1 The standards apply in respect of bedding, haunch support and side support material as defined by NZS 2566.2: and AS/NZS 3725.
- 7.8.6.2 Metal bedding will be in accordance with SD614 and SD615.
- 7.8.6.3 The bedding material will be:



- a) In a sand environment – use compacted saturated sand;
- b) For PVC and flexible pipes - AP20 NZTA M4 or as per AS/NZS 2566.2;
- c) Bedding compaction will be undertaken in accordance with AS/NZS 3725 for type H2 support;
- d) The pipes will be laid and brought to true alignment and level before installing the metal haunching, side support and covering the pipes.

7.8.7 Pipe Embedment

- 7.8.7.1 The metal haunching and side support will be placed uniformly along and around the whole length of the pipe barrel, couplings and other appurtenances in a manner to ensure uniform density of side support (including haunch support) and overlay with no distortion, dislodgement or damage to the pipeline.
- 7.8.7.2 Following placement, the embedment material will be compacted in layers to uniformly support the pipe. When choosing compaction equipment, the number of passes and the thickness of layer to be compacted, account will be taken of the material to be compacted and the pipe to be installed.
- 7.8.7.3 Compaction equipment or methods that produce horizontal or vertical earth pressures that may cause damage to, or excessive distortion of, the pipe will not be employed.
- 7.8.7.4 Metal haunching and side support will be compacted to the manufacturer's requirements and as a guide, a minimum Clegg Impact Value of 35 under vehicle loaded areas or 25 under non-traffic loaded areas will be achieved at any point on any haunching constructed of AP20.

7.8.8 Geotextiles

- 7.8.8.1 Where there is a possibility of migration of fines between the native soil and the pipe surround soil, the DPA will require the metals to be protected by an approved geotextile filter fabric that overlaps by at least 300mm. The extent of this "geotextile wrapping" must be shown on the as-built plans.

7.8.9 Concrete Protection

- 7.8.9.1 Where cover over pipes is less than the minimum as required by the pipe manufacturer and the relevant New Zealand standards, including temporarily under construction traffic, a concrete protection slab will be constructed. The written approval of the Engineering Manager is required for all concrete protection.

7.8.10 Water Stops and Trench Groundwater

- 7.8.10.1 A specific design is needed where permeable bedding is used. Water-stops and trench drainage will be constructed to prevent unwanted movement of groundwater along the trench and pipe bedding, see SD613 (Chapter 6). All captured stormwater must be reticulated to the stormwater network, or at least an approved stormwater outlet.
- 7.8.10.2 Manholes will be considered to be water-stops provided they are constructed appropriately.
- 7.8.10.3 Where water stops are required, they must be provided at the intervals set out in
- 7.8.10.4 Table 7-8.

Table 7-8 Water Stops Spacing and Gradient

Grade	Spacing
1 in 15 or steeper	12m
1 in 15	15m
1 in 25	30m
1 in 100	60m

Note: Intermediate grades (and spacing) are determined by interpolation.

7.8.11 Pipe Installation

7.8.11.1 In respect of pipe installation, Pipes will not be laid on bricks, blocks and wedges or other temporary or permanent supports.

7.8.11.2 Pipes will be kept clear of dirt or debris, and any pipes that contain such matter will be required to be cleaned out. Internal pipe walls will be kept clean and free of all dirt, rubbish and water. Spigots, sockets, rubber rings, fittings etc, will be thoroughly cleaned before jointing.

7.9 Trenchless Technology

This section relates to the use of trenchless technology for the installation of water reticulation.

Mandatory Matters

Council requires the following standards to be met in the use of trenchless technology for the installation of water reticulation:

7.9.1 General

7.9.1.1 Trenchless technology will only be used in specific circumstances where approved by the Engineering Manager.

7.9.1.2 Pipes used for trenchless installation will have suitable mechanically restrained joints, specifically designed for trenchless application, which may include integral restraint, seal systems, or heat fusion welded joints.

7.9.1.3 Any trenchless technology and installation methodology will be chosen to be compatible with achieving the required gravity pipe gradient – refer to the manufacturer's and installer's recommendations.

7.9.1.4 The following details including location of access pits and exit points will be submitted to the Engineering Manager for approval:

- a) Clearances from services and obstructions; the depth at which the pipeline is to be laid to ensure minimum cover is maintained;
- a) The pipe support and ground compaction;
- b) How pipes will be protected from damage during construction;
- c) Any assessed risk to abutting surface and underground structures; and
- d) A clear methodology of how to deal with unknown obstructions and services.

- 7.9.1.5 Gouging or notching of the pipe will not exceed 10% of the pipe wall thickness for pressure pipe and 20% of the pipe wall thickness for gravity pipe. Pipe will not be bent to a radius less than 35 times the pipe OD for PE pipes or 600 times the pipe OD for PVC pipes.
- 7.9.1.6 The specified allowable load on the pipe will not be exceeded during pulling.
- 7.9.1.7 Where gouging or notching exceeds the above limits or if buckling of the pipe occurs, that length of pipe will be removed, and a new section welded in at the nearest join.
- 7.9.1.8 The contractor will over tow the pipe by one lineal metre for each length of pulled pipe that is the greater of one manhole length or 200m. The excess pipe length will be supplied to the DPA for a visual inspection.

7.9.2 Tracer Tape

- 7.9.2.1 For water work a tracer tape system must be incorporated into the trenchless work. The tracer tape must comply with section 7.9.4.
- 7.9.2.2 The location of all water mains will be marked with a foil tape buried in the trench.
- 7.9.2.3 The tape will be blue, 50mm wide, and printed with "CAUTION WATER MAIN BURIED BELOW" or similar message. All printing will be encased to avoid rub-off.
- 7.9.2.4 The tape will be either a woven reinforced acid and alkali resistant polythene plastic with a solid aluminium foil core which will be visible from both sides.

7.9.3 Tracer Tape Installation

- 7.9.3.1 The tape will be buried above the centre line of the pipe within 300mm to 400mm from the finished surface, refer SD702.
- 7.9.3.2 All joints in the tape (e.g. roll ends, accidental breaks and at tees) will be made electrically conductive with purpose made splice clips installed to the specific manufacturer's instructions. Tying together of the tape ends is not acceptable as the polythene coating will prevent electrical conductivity.
- 7.9.3.3 The tape will be brought up inside the surface box risers at all valves and hydrants with a 300mm long tail so that pipe location equipment can be readily connected.

7.9.4 Tracer Wire

- 7.9.4.1 When a pumping main or swallow pipe is installed by a directional drilling technique or bored through the ground for a distance exceeding 20 metres a specific design for traceability is required.

7.9.5 Tape or Wire Testing

- 7.9.5.1 The tracer tape will be tested by the Contractor for continuity using an electric pulse induction system. The test must be witnessed and approved by Council.
- 7.9.5.2 The new watermain/rider main will be tested between any new valves, hydrants etc where the tape is brought up inside the surface box risers. This test will only be undertaken when all work associated with laying the watermain/rider main is complete.

7.9.6 Testing, Disinfection and Connection

- 7.9.6.1 All water supply pipelines to be vested in Council ownership and/or connected to the Council network will pass the hydrostatic pressure test in NZS 4404 Appendix C3 'Pressure pipelines – Field hydrostatic pressure testing'. All final test results sheets are to be included in the package of as-built information provided to Council.
- 7.9.6.2 All new reticulation will be flushed and disinfected to the requirements of NZS 4404, Appendix D – 'Water Supply Disinfection Specification'.
- 7.9.6.3 Connection to existing water main will not be made until all new work (excluding the connection) has been completed and inspected and approved by Council. Specifically, this will include testing, disinfection and flushing of all new pipework, and fittings by the Contractor.
- 7.9.6.4 The developer is to consult with Council as to the requirements of the flushing and disinfection of all new water reticulation. Disinfection of the new water reticulation needs to ensure that there is no *E. coli* and acceptable levels of coliforms in the sourced water. Testing will be on a case by case basis depending on the pipe network size and length of pipe. Council will carry out the final testing etc to determine if the required disinfection has been carried out.

Note:

If *E. coli* re-testing is required by the Council, the costs may be on-charged to the Developer.

Good Practice

The following matters provide additional direction and guidance in the construction and installation of water supply reticulation:

7.9.7 Trenching

- 7.9.7.1 A plate compactor is to be run over the trench floor to bind the surface and identify any obvious weak spots. Where the bottom of an excavation is unable to provide a firm foundation with minimum bearing capacity of 50kPa (e.g., clay soils that can easily be penetrated 40mm with a thumb or in sand or gravel that makes a footprint more than 10mm deep) at the required level without abrupt irregularities, engineering advice should be sought on how to provide a satisfactory foundation (see AS/NZS 2032, clause 5.3.6).
- 7.9.7.2 Where trench support extends below the invert of the pipeline or structure special precautions may be required, including leaving part of the support in place, to ensure the foundation of the pipe or structure is not weakened.
- 7.9.7.3 Ground water lowering may be permitted except where this practice may present a risk of subsidence. Resource consent may be required.

Appendix A Water Meter Location Form

Tasman District Council
 Private Bag 4
 Richmond
 Nelson 7050

To: Water Meter Officer

Subdivision/Meter Location

Resource Consent No. _____ (If applicable).

The following table defines information required by the Council for all new water meters.

- 1) In the Meter Type Column please indicate whether the meter is a Sensus 620M or Elster (Kent) V120 water meter. Indicate either S or E.
- 2) In the Meter Reading Column show the reading to the nearest whole cubic meter only (BLACK NUMBERS on the meter).
- 3) In the Location Column, indicate whether the measurement is from the right or left boundary when facing the lot from the road (R or L) Show one measurement to the meter from either the right or left boundary (measured along the front boundary) and one measurement to the meter from the front boundary (measured perpendicular to the front boundary).

Lot No	D.P No.	Street No.	Street Name	Meter Type S or E	Meter No.	Meter Reading (m3)	Reading Date	Location (Distance from)		
								R/L	Side Bdy (m)	Front Bdy (m)

Lot No	D.P No.	Street No.	Street Name	Meter Type S or E	Meter No.	Meter Reading (m3)	Reading Date	Location (Distance from)		
								R/L	Side Bdy (m)	Front Bdy (m)

(Use additional page if required)

Name: _____

Signature: _____ Date: _____

Address: _____

Appendix B Rural Water Supply – Tasman District Council only

Council operates low-flow rural water supplies outside urban centres over large sections of the Waimea and Moutere areas. Many of the pipelines (laid with the permission of the “then” owner) serving these schemes are not protected by easements but cross large tracts of private land. Connection to some of the schemes are limited by pipeline capacity, water permits conditions and by allocation limits established in the TRMP.

B.1 Connection to Existing Rural Water Supplies

B.1.1 When contemplating subdivisions or development in rural areas, Designers should first ascertain the existence of a water supply reticulation system in the area. Should one exist, the Developer or subdivider will require confirmation from Council that capacity for connection is available if required.

B.1.2 Designers will need to:

- i) Consult the New Zealand Fire Service for cluster developments, to satisfy SNZ PAS 4509.
- ii) Demonstrate that capacity is available for proposed and foreseeable future flows, and
- iii) Verify that an easement for a pipeline can be secured.

B.1.3 Written confirmation of the above will be attached to the subdivision consent application.

B.2 Relocation of Rural Supply Pipelines

B.2.1 Where any development requires relocation of rural water supply pipelines the cost of relocation and the easement will be a charge against the Developer. All relocated pipework located within private property will need to be protected by way of an easement in favour of Council (Note 7.3.11.3). No relocation of a water supply can take place without the approval of Council.

B.3 New Rural Supply

B.3.1 If no public rural water reticulation schemes are available for connection, the consent holder will prove that at least 1.0m³ of potable water per day per lot is available to serve the subdivision. Easements may be required to the water source to secure the supply. (Due to the lack of consistent rainfall in the Tasman area, roof water supply alone cannot be relied upon to service the subdivision). Also an approved water take may be required as set out in the TRMP.

B.4 Rural Connections

B.4.1 Each lot will be serviced by a minimum 20mm diameter service pipe with a restrictor valve as approved by Council to limit supply.

B.4.2 Where water is available, reticulation will be installed and the consent holder will pay the applicable fee for joining and connection of each lot. Joining fees for each scheme together with charges are set out in Council's LTP.

B.4.3 Storage of water on a rural water scheme must comply with Council's Water Supply Bylaw.

B.5 As-Built Drawings

B.5.1 The developers will, whether or not connections are made to the rural scheme, provide as-built plans of the position of rural water supply pipelines relative to the boundaries within the development.

B.6 Rural Fire Fighting Supply

B.6.1 For any dwelling that is not connected to a reticulated water supply incorporating water mains fitted with fire hydrants, with the closest hydrant no more than 135m from the dwelling, it is a requirement of the TRMP (refer Chapter 17) that each dwelling will have either a home fire-sprinkler system that is fitted with a reliable year-round water supply OR;

- B.6.2 The dwelling will have access to a water supply of at least 45,000 litres provided in an approved location solely for fire-fighting purposes. The water must be accessible to fire-fighting equipment. Any water storage must be full at all times.
- B.6.3 The fire-fighting water supply can be from a number of sources; dams, water tanks, pools and lakes, streams and rivers, sea water.
- B.6.4 A fire appliance should be able to sit on a hard-standing area and be no more than 6.0m from the water source (or water supply connection). The water source should be no more than 3.0m below, and no more than 10.0m above the appliance pump inlet.
- B.6.5 A fire service coupling will be required to enable access to the water supply. Appropriate all-weather access for a two-axle truck should be provided to the supply site.

In cluster housing developments in rural supply areas fire-fighting water supplies may be combined. This may include a group of linked tanks above house levels and sited to mitigate visual impact on the landscape (as an alternative to individual tanks on each property). These tanks may be fed from the rural restrictor supply and/or from roof supply and pumps. Easements or consent notices may be required to protect these reservoirs and lines for the lots they serve. These will be provided with access, reticulation (a minimum 100mm diameter main), fittings for fire-fighting purposes and a hard-standing area reserved for fire appliances. The fire service couplings will be no further than 90.0m from, and no closer than 6.0m to the dwelling.

- B.6.6 Further advice and information about managing fire risk and storage of water for fire-fighting, including information about appropriate fittings for connection with fire appliances, can be obtained from the New Zealand Fire Service.

LEGAL ROAD

RIGHT OF WAY /
COMMON ACCESS

EXCLUSIVE DRIVEWAY

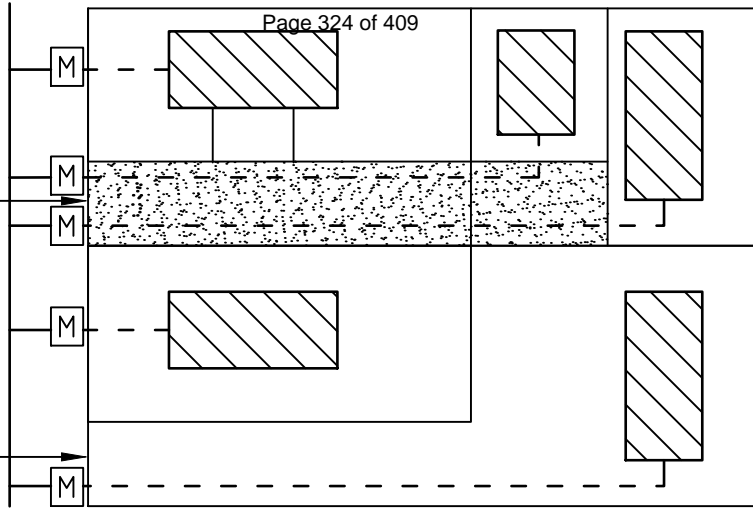

APPROVED

APPROVED

LEGAL ROAD

EXCLUSIVE DRIVEWAY

RIGHT OF WAY /
COMMON ACCESS

EXCLUSIVE DRIVEWAY

RIGHT OF WAY /
COMMON ACCESS

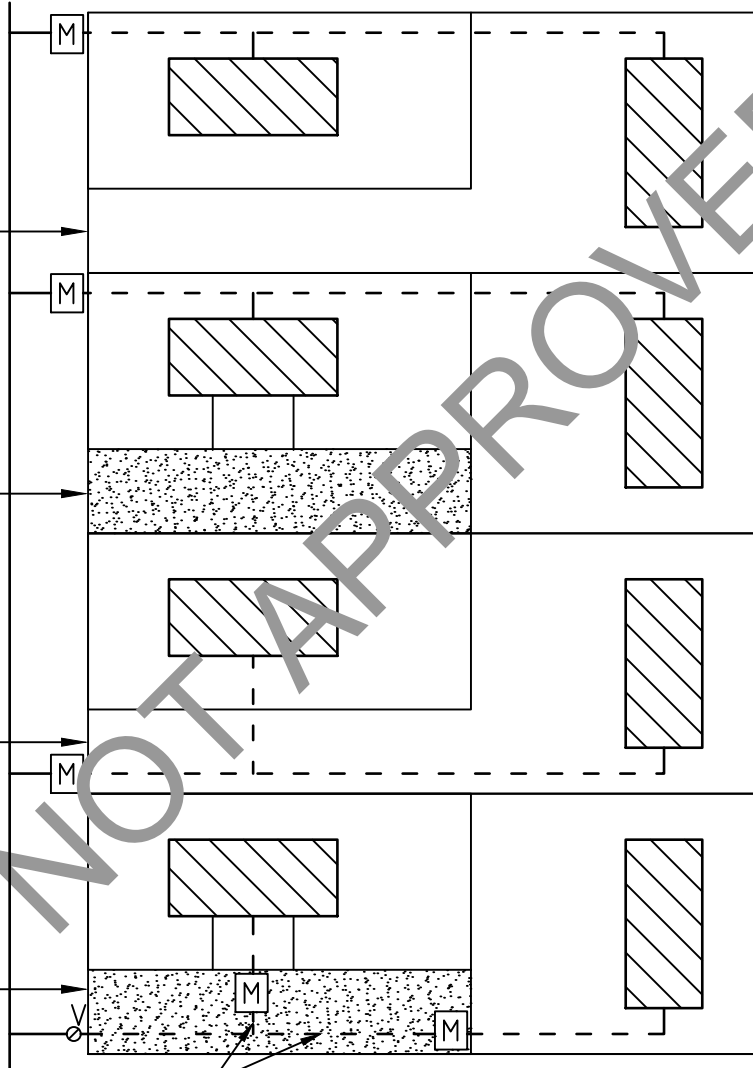

NOT
APPROVED

NOT
APPROVED

NOT
APPROVED

NOT
APPROVED

NOT COUNCIL RESPONSIBILITY

M DENOTES POSITION OF WATER METER ASSEMBLY

V DENOTES POSITION OF VALVE ASSEMBLY

--- PRIVATE

— COUNCIL OWNED

NELSON CITY COUNCIL

GROUP MANAGER INFRASTRUCTURE, NELSON

WATER CONNECTIONS
SUBDIVISION, CROSS LEASE & R.O.W.

TASMAN DISTRICT COUNCIL

ENGINEERING SERVICES MANAGER, TASMAN

DATE

01/07/19

NELSON - TASMAN
LAND DEVELOPMENT MANUAL

701

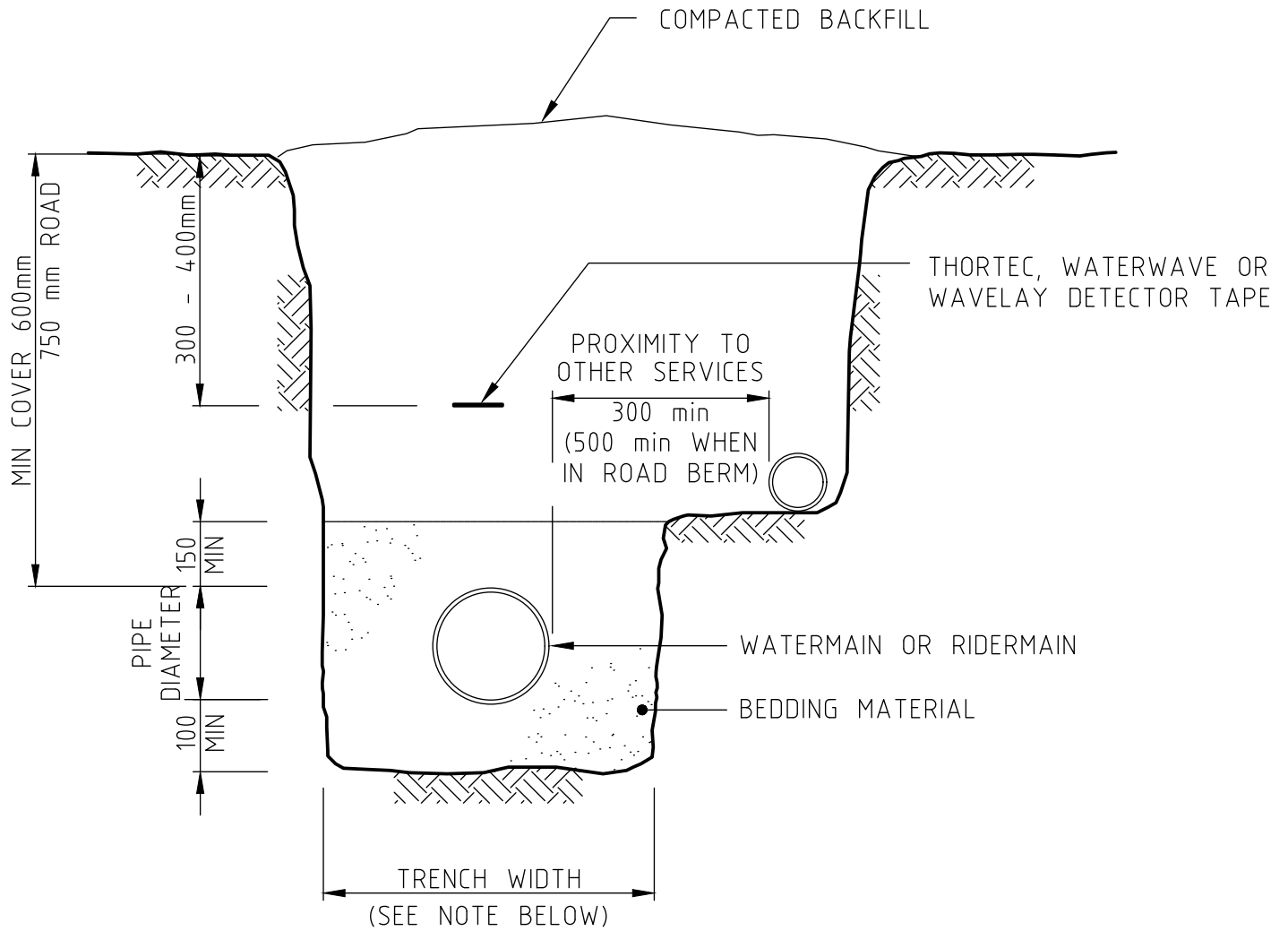

NOTES:

1. SEE DRAWING 614 FOR TRENCH WIDTHS
2. THE TRENCH WIDTH SHALL BE THE MINIMUM NECESSARY TO ADEQUATELY AND SAFELY LAY THE PIPE AND TO COMPACT THE SIDE SUPPORT ZONE

<p>NELSON CITY COUNCIL</p> <p><i>[Signature]</i></p> <p>GROUP MANAGER INFRASTRUCTURE, NELSON</p>		<p>WATER SHARED TRENCH CLEARANCES</p>	
<p>TASMAN DISTRICT COUNCIL</p> <p><i>[Signature]</i></p> <p>ENGINEERING SERVICES MANAGER, TASMAN</p>		<p>DATE</p> <p>01/07/19</p>	<p>NELSON - TASMAN LAND DEVELOPMENT MANUAL</p>
			<p>702</p>

IN TRAFFIC LOADED AREAS/CARRIGEWAYS
INSTALL 200x200 CONCRETE SURROUND
27.5MPa WITH D10 HOOP

IN BERM AREAS INSTALL 150x150
CONCRETE SURROUND

HYDRANT BOXES SHALL BE EMBOSSED
WITH 'FH' ON TOP OF COVER. COVER &
FRAME SHALL BE TO CLASS C STRENGTH
IN BERM ACCESS OR CLASS D IF IN
TRAFFIC LOADED AREAS, TO AS3996.
COVER MUST BE ANTI-ROCKING

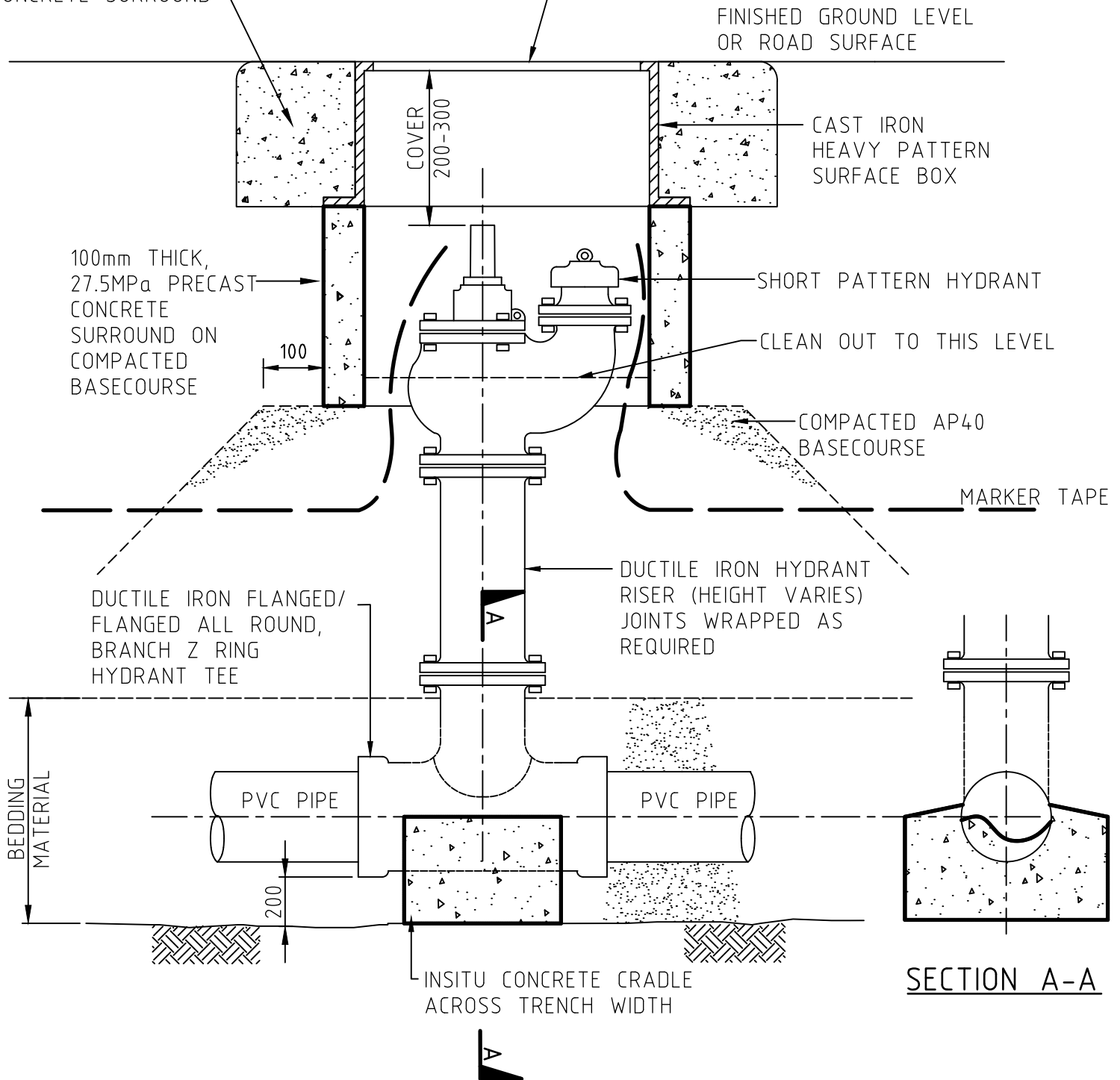



FLANGED TEE ANCHOR - REFER TO
DRAWING 704: SLUICE VALVE INSTALLATION

<p>NELSON CITY COUNCIL</p> <p><i>[Signature]</i></p> <p>GROUP MANAGER INFRASTRUCTURE, NELSON</p>		<p>FIRE HYDRANT INSTALLATION</p> <p>Z RING JOINTED</p>	
<p>TASMAN DISTRICT COUNCIL</p> <p><i>[Signature]</i></p> <p>ENGINEERING SERVICES MANAGER, TASMAN</p>	<p>DATE</p> <p>01/07/19</p>	<p>NELSON - TASMAN</p> <p>LAND DEVELOPMENT MANUAL</p>	<p>703</p>

IN TRAFFIC LOADED AREAS/CARRIGEWAYS
 INSTALL 200x200 CONCRETE SURROUND
 27.5mPa WITH D10 HOOP

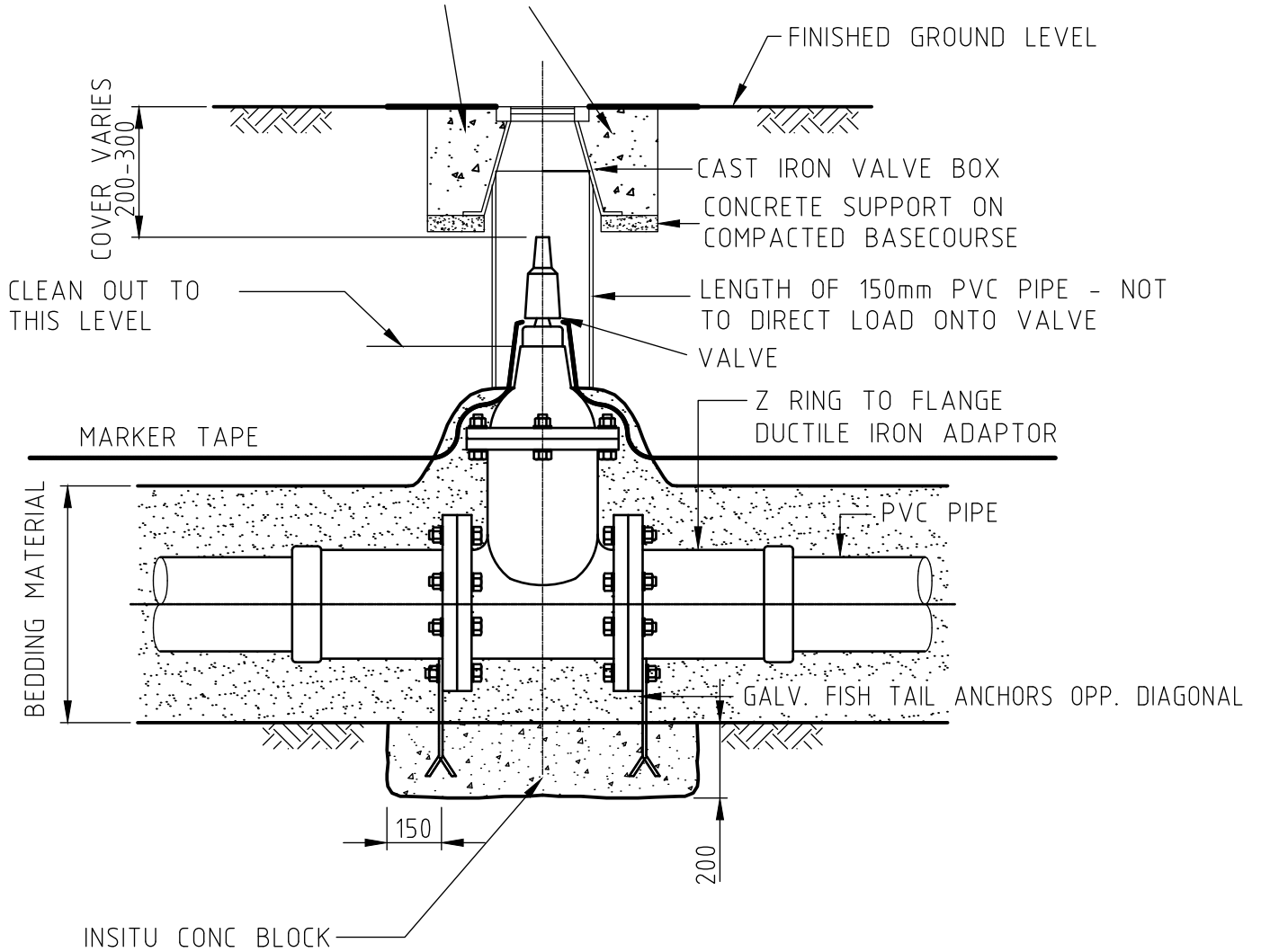
IN GRASSED OR VEGETATED AREAS
 INSTALL 150x150 CONCRETE SURROUND



NELSON CITY COUNCIL  GROUP MANAGER INFRASTRUCTURE, NELSON		<h2>SLUICE VALVE INSTALLATION</h2>	
TASMAN DISTRICT COUNCIL  ENGINEERING SERVICES MANAGER, TASMAN		DATE 01/07/19	NELSON - TASMAN LAND DEVELOPMENT MANUAL
			704

TO BE LOCATED IN AN APPROVED VALVE BOX

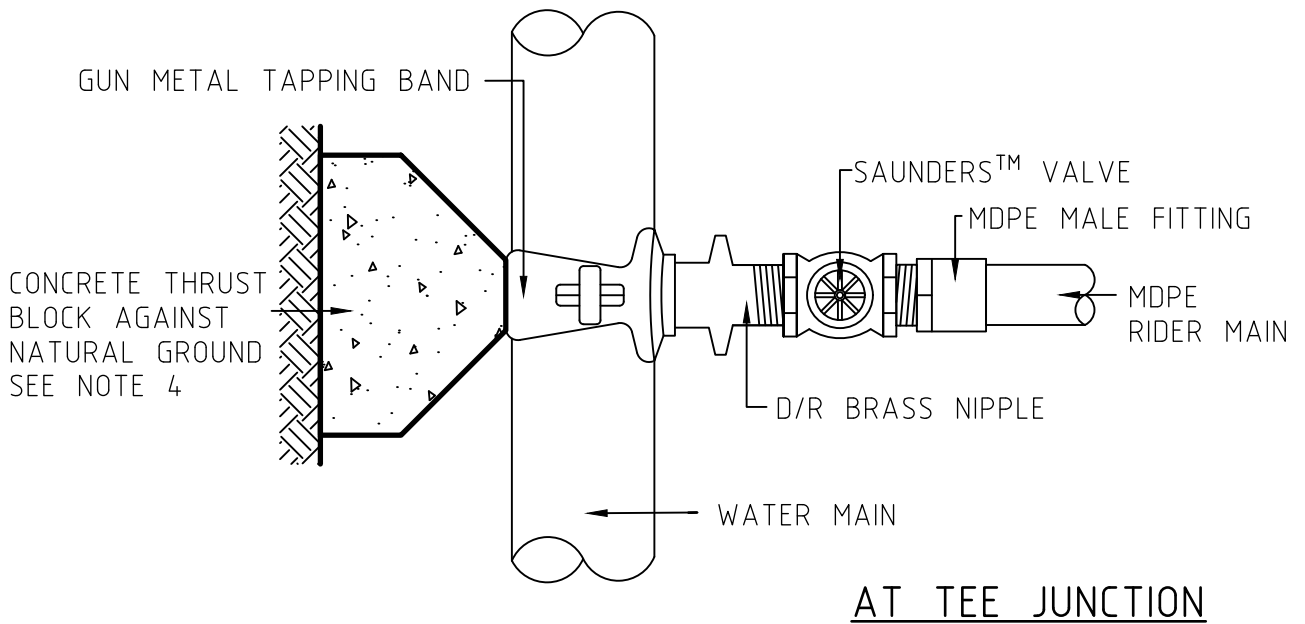
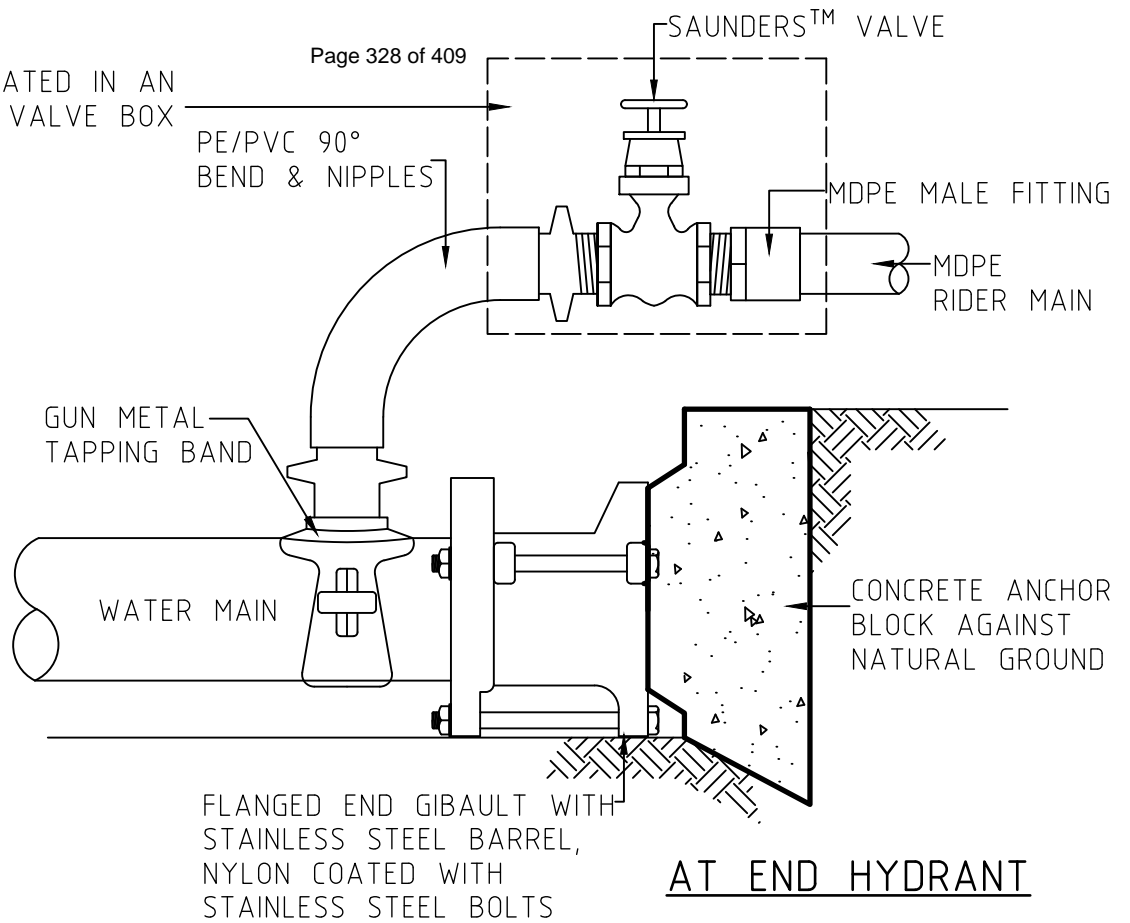

NOTES

1. ALL COMPONENTS TO BE COUNCIL APPROVED
2. THIS DIAGRAM APPLIES TO THE SITUATION WHERE THE MAIN IS LOCATED IN THE FOOTPATH OR BERM WHERE THE MAIN IS LOCATED IN THE ROAD THE LAYOUT SHALL BE MODIFIED SO THAT THE SAUNDERS™ VALVE IS LOCATED IN THE FOOTPATH OR BERM.
3. FOR 50mmØ RIDERMAINS A SLUICE VALVE IS REQUIRED and THEREFORE THE COPPER 'UPSTAND' SHALL BE OMITTED.
4. NO CONCRETE TO BE POURED AGAINST PIPE

NELSON CITY COUNCIL

[Signature]
GROUP MANAGER INFRASTRUCTURE, NELSON

TAPPING BAND RIDER MAIN CONNECTION

TASMAN DISTRICT COUNCIL

[Signature]
ENGINEERING SERVICES MANAGER, TASMAN

DATE
01/07/19

NELSON - TASMAN
LAND DEVELOPMENT MANUAL

705

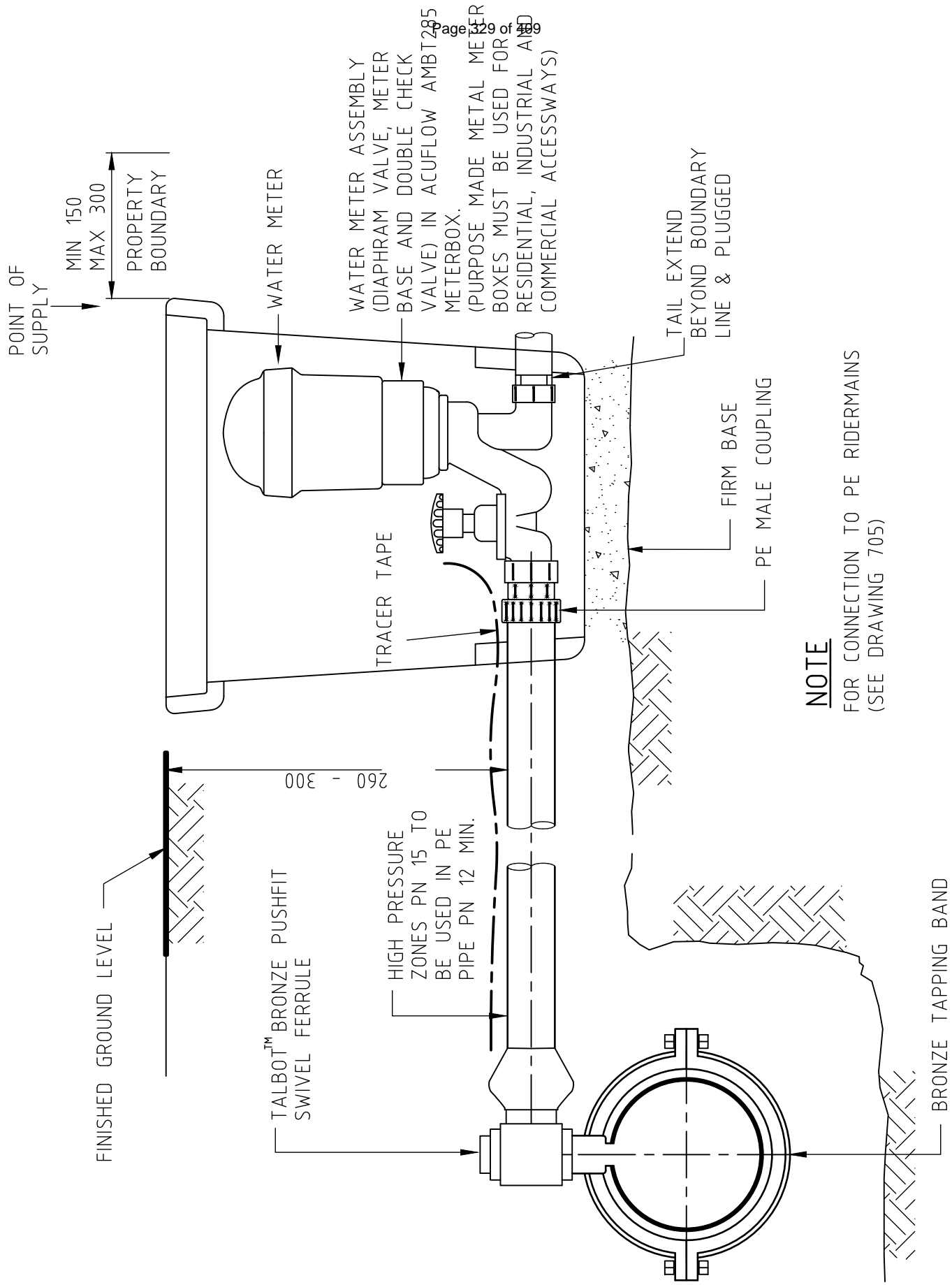

NOTE

FOR CONNECTION TO PE RIDERMAINS
(SEE DRAWING 705)

NELSON CITY COUNCIL

 GROUP MANAGER INFRASTRUCTURE, NELSON

**WATERMAIN LATERAL FOR
PROPERTY CONNECTION**

TASMAN DISTRICT COUNCIL

 ENGINEERING SERVICES MANAGER, TASMAN

DATE
01/07/19

NELSON - TASMAN
LAND DEVELOPMENT MANUAL

706

SURFACE PREPARATION

WIRE BRUSH LOOSE DIRT AND RUST FROM THE FLANGE AND ADJACENT PIPE, IF APPROPRIATE AND 100mm ONTO ANY SHOP COATING. ENSURE ALL SURFACES ARE CLEAN. DENSO PRIMER CAN BE APPLIED TO MOIST OR DAMP SURFACES, BUT VERY WET SURFACES SHOULD BE DRIED

PRIMING

APPLY DENSO PRIMER TO ALL METAL SURFACES WHERE POSSIBLE, PROTECT NUTS AND BOLTS BY DIPPING IN DENSO PRIMER BEFORE ASSEMBLY

FILLING

FLANGES TO TABLES A & D MOULD DENSO MASTIC OVER THE HEADS OF BOLTS, NUTS AND SCREW THREADS WITH A MINIMUM COVERAGE OF 5mm TAPER ONTO FLANGE FACE TO PROVIDE A SUITABLE CONTOUR FOR TAPE WRAPPING FLANGES TO TABLES E DUE TO THE INCREASED NUMBER OF BOLTS IN THIS CASE, IT IS NECESSARY TO USE DENSO MASTIC BETWEEN INDIVIDUAL BOLTS AND NUTS TO PROVIDE A SUITABLE CONTOUR FOR TAPING

WRAPPING

APPLY ONE COMPLETE TURN OF DENSO TAPE CIRCUMFERENTIALLY AROUND FLANGE WITH ONE SIDE AGAINST THE EDGE OF THE THE FLANGE. OVERLAP ABOUT 80mm. MOULD THE OVERHANGING TAPE OVER THE MASTIC. APPLY A SECOND TURN OF TAPE TO PROVIDE A DOUBLE THICKNESS AROUND THE FLANGE AND COVER THE OPPOSITE SIDE FOR FLANGES ON SHOP COATED LINES, SPIRALLY WRAP DENSO TAPE FROM THE PROTECTED FLANGE AND 100mm ONTO THE SHOP COATING ON EITHER SIDE.

OVERWRAPPING

ENVELOPE WITH DENSO MP/HD TAPE

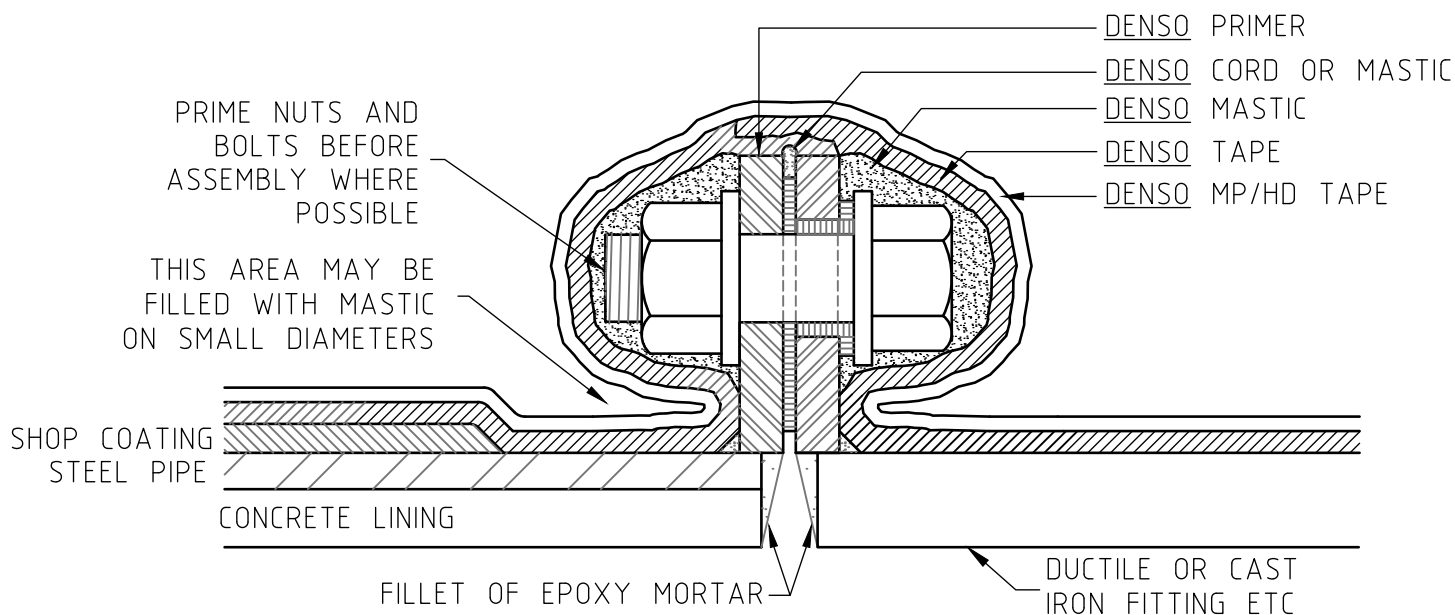

NELSON CITY COUNCIL

[Signature]
GROUP MANAGER INFRASTRUCTURE, NELSON

**CORROSION PROTECTION
FOR FLANGES**

TASMAN DISTRICT COUNCIL

[Signature]
ENGINEERING SERVICES MANAGER, TASMAN

DATE
01/07/19

NELSON - TASMAN
LAND DEVELOPMENT MANUAL

707

Page 934 of 409

ALL UNRESTRAINED MECHANICAL COUPLINGS SHALL BE WRAPPED AS DETAILED BELOW WHERE MATERIALS OTHER THAT 316 STAINLESS STEEL AND COATINGS TO AS/NZS 4158 ARE USED.

SURFACE PREPARATION

WIRE BRUSH LOOSE DIRT AND LOOSE RUST FROM THE JOINT AND ADJACENT PIPE.
DENSO PRIMER CAN BE APPLIED TO MOIST OR DAMP SURFACES, BUT VERY WET SURFACES SHOULD BE DRIED

PRIMING

APPLY DENSO PRIMER TO ALL METAL SURFACES
 WHERE POSSIBLE, PROTECT NUTS AND BOLTS BY DIPPING IN DENSO PRIMER BEFORE ASSEMBLY

FILLING

FILL BETWEEN BOLTS AND SLEEVE, AND BOLTS TO TOP FLANGES WITH DENSO MASTIC
 COVER BOLT HEADS, NUTS AND ANY PROTRUDING THREAD WITH DENSO MASTIC

WRAPPING

WHERE A SERVICE TAPPING MAY BE INCLUDED WITH THE UNRESTRAINED MECHANICAL COUPLING, APPLY ONE COMPLETE TURN OF DENSO TAPE AROUND THE JOINT LAPPING BOTH ENDS ONTO THE SERVICE PIPE.
 APPLY DENSO TAPE AROUND ONE END OF JOINT WITH AN END LAP OF 80mm. MOULD THE TAPE FROM THE HIGHEST POINT ON THE FLANGE WORKING DOWN TO EXCLUDE AIR BUBBLES.
 APPLY ANOTHER COMPLETE TURN OF TAPE SIMILARLY WITH MINIMUM SIDE LAP OF 20mm. MOULD THE TAPE AROUND THE MASTIC COVERED BOLT HEADS, E.T.C.



OVERWRAPPING

ENVELOPE WITH DENSO MP/HD TAPE

NOTE

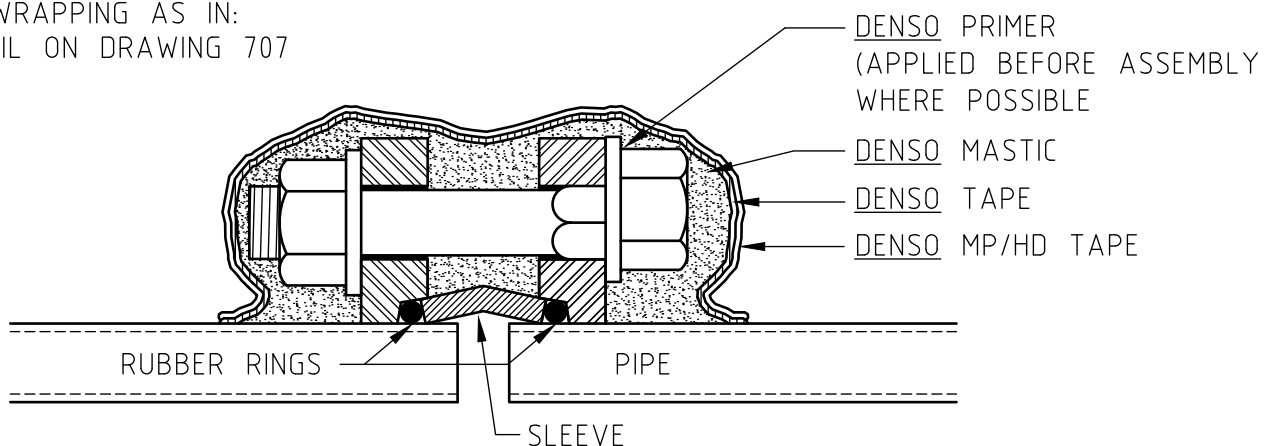
FOR CONCRETE LINED STEEL PIPES
DENSO SYSTEM TO OVERLAP
 ONTO SHOP WRAPPING AS IN:
 FLANGE DETAIL ON DRAWING 707

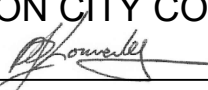

NELSON CITY COUNCIL  GROUP MANAGER INFRASTRUCTURE, NELSON		CORROSION PROTECTION FOR UNRESTRAINED MECHANICAL COUPLINGS	
TASMAN DISTRICT COUNCIL  ENGINEERING SERVICES MANAGER, TASMAN	DATE 01/07/19	NELSON - TASMAN LAND DEVELOPMENT MANUAL	708

VALVE CODING:

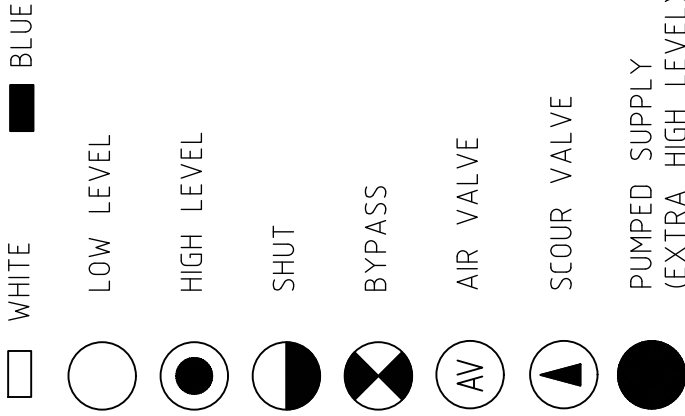

NOTES

1. PAINT USED FOR ALL ROAD MARKINGS SHALL BE NZTA M07 "ROAD MARKING PAINT" COLOUR AS ABOVE.
2. ALL HYDRANT KERB MARKINGS SHALL BE YELLOW AND ALL VALVE KERB MARKINGS SHALL BE BLUE.

F.H. MARKER POSTS INSTALLED ONLY AS DIRECTED BY THE ENGINEER.

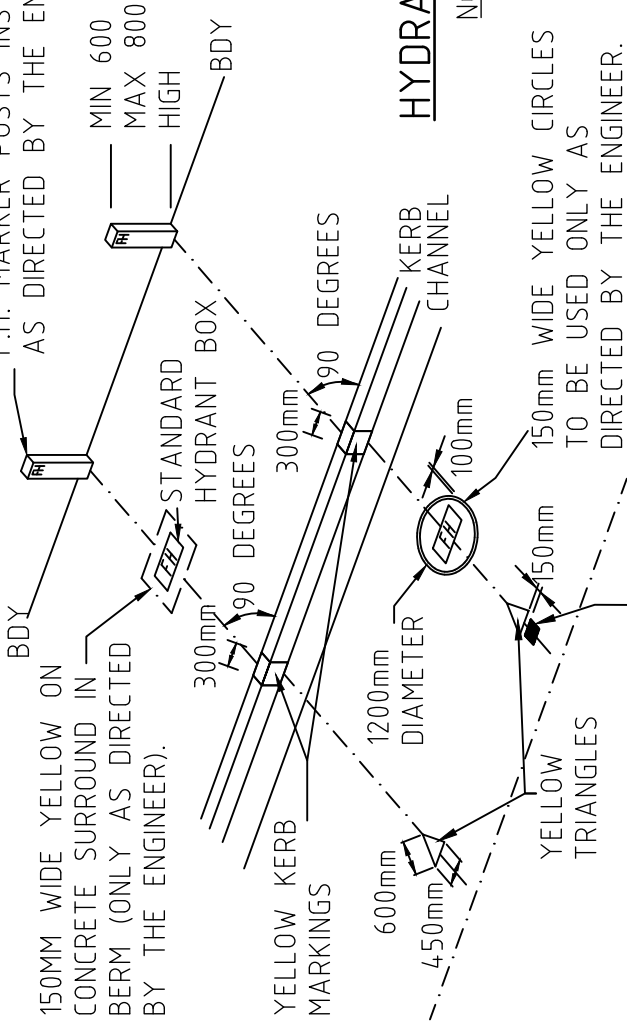

BLUE RAISED REFLECTIVE PAVEMENT MARKER AT OR CLOSE TO, AND ON THE APPROPRIATE SIDE OF, THE CENTRE OF THE ROADWAY AT OR NEAR THE BASE OF THE YELLOW TRIANGLE MARKER.

S.V. MARKER POSTS INSTALLED ONLY AS DIRECTED BY THE ENGINEER.

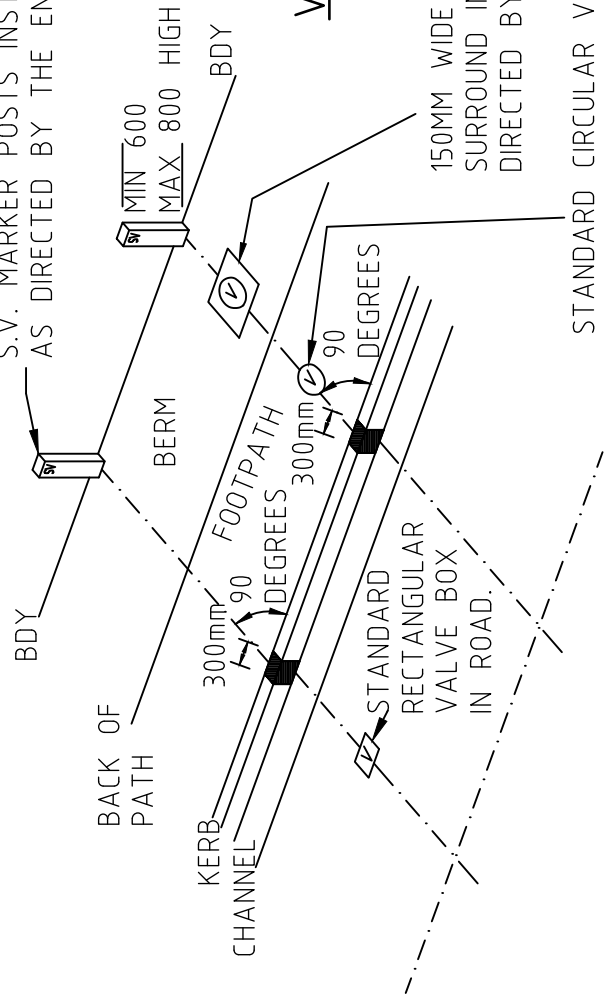

NELSON CITY COUNCIL

[Signature]
GROUP MANAGER INFRASTRUCTURE, NELSON

VALVE AND HYDRANT ROAD MARKINGS

TASMAN DISTRICT COUNCIL

[Signature]
ENGINEERING SERVICES MANAGER, TASMAN

DATE
01/07/19

NELSON - TASMAN
LAND DEVELOPMENT MANUAL

709



Chapter 8

Earthworks, Trenching and Reinstatement

TABLE OF CONTENTS

CHAPTER 8 EARTHWORKS, TRENCHING AND REINSTATEMENT MANAGEMENT

INTRODUCTION	1
8 PURPOSE	1
8.1 Performance Outcomes.....	1
8.2 Referenced Documents	1
8.2.1 Resource Management Plan Requirements.....	1
8.2.2 External Standards	1
STANDARDS	2
8.3 Design	2
Mandatory Matters	2
8.3.1 General	2
8.3.2 Corridor Access Requests	2
8.4 Construction	3
Mandatory Matters	3
8.4.1 General	3
8.4.2 Notice.....	3
8.4.3 Street closure.....	4
8.4.4 Underground services.....	4
8.4.5 Road marking	4
8.4.6 Managing Disturbances	5
8.4.7 Restoration and Remediation	6
8.4.8 Surface Excavation	7
Good Practice.....	8
8.5 Excavation	9
Mandatory Matters	9
8.5.1 General	9
8.5.2 Footpath Reinstatement	10
8.5.3 Berms and Shoulders	11
Good Practice.....	11
8.6 Subsoil drainage	12
Mandatory Matters	12
Good Practice.....	13

LIST OF TABLES

Table 8-1 Standards and Publications Related to the Design and Construction of Water Supply Services	2
---	---

CHAPTER 8 EARTHWORKS, TRENCHING AND REINSTATEMENT MANAGEMENT

INTRODUCTION

8 PURPOSE

The purpose of this section is to clearly outline Council's requirements for excavation, backfilling and reinstatement work, and sub-soil drains, within the road reserve and public property.

8.1 Performance Outcomes

Earthworks, trenching, reinstatement and sub-soil drains performance outcomes for network assets sought by these standards are as follows:

- a) The health and safety of the public, particularly the local community, has been ensured;
- b) The level of the service is as good as or better than the existing standard of service following the new excavation works;
- c) All practicable steps have been taken to minimise the level of disruption;
- d) Council has been informed of excavation works and all steps have been taken to follow standards and conditions of notification;
- e) Any affected or potentially affected persons have been notified in advance of the proposed disruption;
- f) Remediation and reinstatement works have been completed to the same or higher standard than prior to the initiation of works;
- g) Sub-soil drains are designed and constructed to manage the effects of mass earthworks, without the need for on-going monitoring and maintenance by Council;
- h) All sub-soil drains are geotechnically designed and certified.

8.2 Referenced Documents

8.2.1 Resource Management Plan Requirements

The Standards set out in this chapter address matters that are specific to Council asset creation or activities that may have an impact on an asset. They are subject to the Nelson City and Tasman District Resource Management Plans. Key sections of the plans that may relate to trenching and reinstatement works are earthworks and land disturbance provisions.

8.2.2 External Standards

Unless otherwise specified within the standards of this document, earthworks, trenching and reinstatement management networks will be designed and constructed in a manner consistent with the standards set out in Table 8-1. Where an Act or National Standard document is referenced, this will be the current version including any associated amendments.

Table 8-1 Standards and Publications Related to Earthworks, Trenching and Reinstatement

Standard	Comment
National Code of Practice for Utilities, Access to the Transport Corridors.	Working on the Road - for Temporary Traffic Control and Safety at Roadwork Sites
NZS 6803	Acoustics – Construction Noise
NZS 3116	Concrete segmental and flagstone paving
NZS 4402	Methods of Testing Soils for Civil Engineering purposes
NZS 4404	Land development and subdivision infrastructure
NZS 4431	Code of practice for earth fill for residential development
Ministry for the Environment	National Environment Standard – Telecommunication Facilities

STANDARDS

8.3 Design

This set of standards relates to the general preparation and process requirements of trenching and reinstatement on public land.

Mandatory Matters

Council requires the following standards to be met with trenching and reinstatement works:

8.3.1 General

- 8.3.1.1 Except for transformers and cabinets and unless resolved otherwise by the Council, all new telecommunications, broadcasting and electricity cables, fittings and equipment in the road reserve will be laid underground.
- 8.3.1.2 Only operators approved by the Council will be permitted to undertake trenching and reinstatement works within road reserves within the Council's area. See Chapter 2, Qualifications, Process and Information Requirements.

8.3.2 Corridor Access Requests

- 8.3.2.1 A Corridor Access Request (CAR) as set out in the 'National Code of Practice for Utilities, Access to the Transport Corridors' is required to be lodged by the operator at the Council for each separate job or section of a continuing job, which involves excavation, or the lifting of the surface within a road reserve. Further information about CAR applications and fees is available on the Council's website.
- 8.3.2.2 For minor work the CAR must be lodged at least five working days before work starts, unless otherwise agreed. For major and project work, the CAR must be lodged at least fifteen working days before work starts, unless otherwise agreed.
- 8.3.2.3 Where emergency maintenance is necessary, the notice will be lodged on the next working day. If the road involved is a State Highway, the notice will require confirmation that the New Zealand Transport Agency has been notified and if any special conditions imposed by that body have been received.

- 8.3.2.4 Plans of the proposed work will be submitted to the Council with the CAR. The plans will be to a scale of 1:500 or 1:200 where needed for clarity and shall show the location and size of all existing and proposed cables, conduits, pipes, underground structures, property boundaries and kerb lines. Unless agreed otherwise, dimensions to boundaries and kerbs will be shown and proposed depths below existing surface levels shall be shown at regular intervals.
- 8.3.2.5 As-built plans will be made available on request of the Corridor Manager and no later than three months following the completion of the works.
- 8.3.2.6 The operator will advise other affected Service Authorities a minimum of 15 days prior to any proposed construction works. Confirmation that other affected Service Authorities have been advised of planned works shall be indicated on the CAR.
- 8.3.2.7 Providing that all required information has been supplied with the CAR, the Council will issue a Work Approval Notice (WAN) and advice of existing Council services in the locality and any specific conditions related to the proposal. No works may commence in advance of the WAN being issued. WAN are valid for six months from the date of issue unless agreed otherwise by the Engineering Manager.
- 8.3.2.8 A charge for each WAN issued will be made in accordance with the fees and charges that may be set by the Council from time to time.

8.4 Construction

This set of standards relates to the physical works associated with trenching and reinstatement construction practices.

Mandatory Matters

Council requires the following standards to be met when undertaking trenching and reinstatement of underground services:

8.4.1 General

- 8.4.1.1 Normal work hours will be between 0700-1800 hours, Monday to Saturday. Works on arterial streets may be limited to 0900-1600 hours or other hours as may be appropriate.
- 8.4.1.2 Work hours within the Nelson Central City, Stoke, Richmond, Motueka and Takaka town centres, will be as approved by the Council.
- 8.4.1.3 During any construction in the street, the disruption to the public and adjacent residents will be kept to a minimum.
- 8.4.1.4 Noise created by construction will be kept to a minimum and shall not exceed the levels described in Part 5 of NZS 6803.
- 8.4.1.5 Trench reinstatement in carriageways and footpaths will be as shown in SD801 and SD802.

8.4.2 Notice

- 8.4.2.1 Prior to planned excavation commencing, the operator will give written notice (48 hours) to all affected residents and business owners of the nature of the work and who to contact for further information or to convey complaints.

- 8.4.2.2 There will be 24 hours' notice given to the occupiers of any property which will have its access blocked for more than one hour and will be notified in writing and in sufficient time to enable them to remove any vehicles etc from their property. The operator will also ensure parked cars etc are moved off the site.
- 8.4.2.3 All operators who carry out work which may impact on the normal use of the roads and/or footpaths must submit a Traffic Management Plan to Council for approval before commencing works.
- 8.4.2.4 The operator will, as a minimum, comply with the requirements of the Council Traffic Management Guidelines and submit a Traffic Management Plan prior to the commencement of work.
- 8.4.2.5 The operator will be responsible for the supply, erection and maintenance of all necessary barricades, lights, warning notices, traffic control signs etc.

8.4.3 Street closure

- 8.4.3.1 The carriageway will be fully open to traffic during hours of darkness and not more than half the carriageway shall be closed at any one time, except with the express permission in writing of the Council.
- 8.4.3.2 Any street closed to any traffic must obtain specific written approval of the Council.
- 8.4.3.3 The closure of any streets requires public notification.
- 8.4.3.4 Application to close a street for infrastructure-related activities must be lodged at Council at least 40 days prior to the day of the proposed closure.
- 8.4.3.5 Approval for street closure will only be given where all other options are unsatisfactory.

8.4.4 Underground services

- 8.4.4.1 The positioning of services or mains, wherever possible, will be in accordance with SD412 and SD413.
- 8.4.4.2 The operator will make itself fully aware of the position of all underground services in the locality, before commencing work.
- 8.4.4.3 Variations from these alignments will be by written agreement from the Council, following discussions with other affected Service Authorities.
- 8.4.4.4 Where existing services are damaged as a result of the construction work, the operator will immediately advise the owner of the damaged services, (public or private).
- 8.4.4.5 The cost of repair or reinstatement of any disturbances or damage to any water pipe, sewer or stormwater drain, other underground services or structure, will be borne by the operator.

8.4.5 Road marking

- 8.4.5.1 All works that are likely to cause damage to any road markings must be brought to the attention of the Council in order that they may be replaced at the earliest possible opportunity for the safety of the general public.
- 8.4.5.2 The operator will be responsible for the cost of any remarking that is necessary.

- 8.4.5.3 All road marking will be undertaken by a registered Road Marking Contractor to the current New Zealand Transport Agency standards.
- 8.4.5.4 Road marking will be completed within five days of resurfacing. Limit lines must be replaced when trafficked. This can be a temporary marking for the first five days.
- 8.4.5.5 All edgelines, centrelines, continuity lines and limit lines will be reflectorised road markings.

8.4.6 Managing Disturbances

- 8.4.6.1 The operator will avoid disturbance to any survey marks within the vicinity of their work. Where any survey marks are disturbed, the cost of replacing and re-surveying the mark shall be met by the operator.
- 8.4.6.2 Reinstatement of geo-fabrics and geogrids will be undertaken as detailed on SD806.
- 8.4.6.3 Trenchless technology will only be used in specific circumstances where approved by the Engineering Manager.
- 8.4.6.4 The maximum permitted length of trench to be open shall be 100m unless specifically authorised by the Council. Notwithstanding this, the operator will not exceed any length that is not capable of being backfilled and opened to traffic in the same day, nor will it interfere with two-way traffic flow.
- 8.4.6.5 Trench widths will be kept to the minimum necessary to lay the service and correctly compact the backfill.
- 8.4.6.6 Open trenches will not be permitted overnight without the prior authority of the Council.
- 8.4.6.7 All works that are likely to cause damage to any trees, shrubs, or ornamental gardens within the road reserve, will be brought to the attention of the Council prior to work commencing. It will be the operator's responsibility to make good or replace any damaged trees, shrubs or ornamental gardens.
- 8.4.6.8 All open trenches will be maintained in a dewatered condition and water-logged material removed to the satisfaction of the Council. Sediment laden water from any excavation will be disposed of to the stormwater main via a sediment retention device or settlement tank to minimise sedimentation and avoid damage or nuisance.
- 8.4.6.9 The operator will take all due care to prevent excavated and stockpiled material from being washed into the stormwater system in the event of rain occurring during a trenching operation
- 8.4.6.10 Where damage occurs to existing kerb and channel the damage will be made good to the satisfaction of the Council. Where any kerb and channel requires replacing this shall be done by the Council's approved kerbing contractor at the operator's expense.
- 8.4.6.11 Where work is to take place within 50m of traffic signals the operator will consult with the Council.
- 8.4.6.12 The operator will liaise with the Council to locate the traffic signals communication network.
- 8.4.6.13 All earthworks and land disturbance activity will cease immediately upon the discovery of cultural heritage artefacts, in accordance with the Heritage New Zealand Pouhere Taonga Act 2014.

8.4.6.14 Where there is a known high risk of accidental discovery, a cultural heritage monitor must be present during all excavation works.

8.4.7 Restoration and Remediation

8.4.7.1 As work proceeds the operator will progressively carry out all restoration and tidying up work.

8.4.7.2 On completion of the work, the operator will remove all plant, materials and other things that may have been brought upon the site in aid of the works, and generally clear away all rubbish and leave the site in a similar or better condition to that which existed before the work was commenced.

8.4.7.3 Any trees or branches cut down or tree stumps uprooted during the work will be removed.

8.4.7.4 If regular tidying up and restoration is not being done, the Council will require and instruct the operator concerned to carry out this work immediately.

8.4.7.5 The operator will, at its own expense, clean out all sumps and repair or reinstate all road surfaces, fencing, walls, floors, lawns, gardens, paths, inclusive of transplanting trees and shrubs, and make good all damage which may have been caused through his operations to at least as good as the "as found condition" in connection with the work.

8.4.7.6 Surface reinstatement (including the final or temporary sealing) will be completed prior to vehicle and pedestrian traffic being permitted to use the surface. Surface reinstatement shall be completed within five days of the trench being opened or such other period agreed by the Council.

8.4.7.7 Where work is required within an area that has been re-surfaced within the last two years an alternative route must be identified. If this is not possible then, depending on the position and nature of the excavation, a full width reinstatement may be required. Where a full width reinstatement is required, then the length of the reinstatement will be not less than the width of the carriageway (or footpath).

8.4.7.8 All temporary markings to locate services will be removed on completion of the works.

8.4.7.9 All permanent surface reinstatement on carriageways will be completed with the finished wearing surface depth, matching that of the existing road and finishing flush with the final seal level or as per Section 4.17.5.4. All parts of the surface damaged during or as a result of the work will have a reinstated sealed surface. Excavations that are closer than 1.0m horizontal to the existing edge of the seal, kerb and channel, or previous excavation reinstatement, or joint will have a reinstated sealed surface that extends to join with the existing edge of seal, kerb and channel or adjacent reinstatement.

8.4.7.10 Subject to favourable weather conditions, appropriate Polymer Modified Bandage (PMB) 100mm wide by 1.5mm thick, will be completed within five days of resurfacing.

8.4.7.11 Service boxes, e.g. water hydrant boxes, manholes etc will be installed in their final location during trench compaction and their finished level shall be finished flush with or no more than 5mm above the reinstated pavement surface. All service boxes and lids will be raised and adjusted to final level prior to placement of surfacing seal coat.

8.4.7.12 For State Highways, refer to New Zealand Transport Agency requirements.

- 8.4.7.13 All permanent surface reinstatement on footpaths will be completed with a finished surface matching the existing and finishing flush with the existing surface. The minimum dimension of any reinstated portion of the footpath will not be less than 600mm wide. The width of remaining undamaged footpath will not be less than 1.0m. If these criteria cannot be met the reinstatement will be across the full width of the footpath. Also, the full width of the footpath will be replaced when trenching in footpaths within the Central Business District (CBD) areas, or Arterial, and Principal roads or new footpaths with a sealed surface less than two years old, see SD803, SD804 and SD805.
- 8.4.7.14 In concrete footpaths the depth will match the existing with a minimum thickness of 100mm and the concrete shall attain a minimum compressive strength of 27.5 MPa after 28 days, as per SD406 and SD407. Construction joints will be formed at 6.0m centres and the line and level of the finished surface shall match the crossfall and level of the adjacent undamaged surface.
- 8.4.7.15 In footpaths, service boxes, e.g. water hydrant boxes, manholes etc will be installed in their final location during trench compaction and their finished level will be finished flush with the reinstated pavement surface. All surface boxes and lids will be raised and adjusted to final level prior to placement of surfacing seal coat.
- 8.4.7.16 For reinstatement within grassed berms see Chapter 4, Section 4.15.2.
- 8.4.7.17 Alternatively, turfs may be cut from the berm 75mm in thickness and 50mm wider than the trench and stacked for re-use. Full reinstatement will be achieved within 48 hours with screened top soil being raked into all cut joints, with all turfs being adequately watered immediately following completion of reinstatement.
- 8.4.7.18 Service boxes etc will be finished to the tolerances specified in Chapter 4, Section 4.17.5.4 unless in a planted/landscaped (non-pedestrian) area then surface lids will be finished to 40mm higher than surrounding finished surface.
- 8.4.7.19 The operator will notify the Council (via a Works Completion Notice) immediately upon the completion of final reinstatement so that an inspection may be made of the completed surface reinstatement works.
- 8.4.7.20 The operator will be held responsible for any street maintenance work required as a result of the excavation and reinstatement operations for a minimum of 24 months after notification to the Council that the final surfacing material has been applied including Polymer Modified Bitumen (PMB) and Road Marking. Any such maintenance work required by Council will be undertaken by the operator at the operator's cost within five working days of being notified by the Council to undertake repair works.
- 8.4.7.21 If on the grounds of safety, there is a need for more immediate action this remedial work will be completed within 48 hours or such other time as may be directed by the Council. Should this not be complied with, Council reserves the right to arrange or undertake such maintenance work and this work will be at the cost of the operator. The maintenance period will start from the time that the Council is notified of completion of remedial works.

8.4.8 Surface Excavation

- 8.4.8.1 When an excavation is required to be made through any cement concrete, asphaltic concrete or chip seal surface, the proposed edges of the excavation or trench will be cut with a power saw prior to the excavation of the trench. The cut is to extend through the full thickness of the surface layer in

a clean straight vertical line. The cut will be 150mm beyond and parallel to the edge of the trench or to a line outside any pavement damage, whichever is greater. Within footpaths all saw cuts will be parallel to or at right angles to the centreline of the footpath.

- 8.4.8.2 Only wet cutting will be permitted in the CBD, in the vicinity of Suburban Shopping Centres or where directed by the Council, to minimise the problems caused by dust.
- 8.4.8.3 Unless approved otherwise by the Engineering Manager, all excavated material will be removed from the site immediately as excavation proceeds.
- 8.4.8.4 Areas adjacent to the excavation will not be undercut. If slumping of material from the sides of the excavation causes depressed areas adjacent to the excavation or if the edges of the pavement are lifted during excavation, additional saw cutting outside of the original line of the excavation and outside the area of damage will be required before reinstatement is permitted.

Good Practice

The following matters provide additional guidance and direction in the provision of trenching and reinstatement of underground services.

- 8.4.8.5 Arrangements may need to be made to damp down work areas and excavated material as required from time to time to eliminate any dust nuisance.
- 8.4.8.6 The operator's attention is drawn to the employees' and sub-contractor's obligations under the Health and Safety at Work Act 2015.
- 8.4.8.7 Should the operator wish to use any alternative methods of traffic control, the prior consultation with and approval of the Council will be required.
- 8.4.8.8 Should the Police, Worksafe or the Council consider at any time there is a risk to traffic, the general public or the operator's employees, the operator will immediately provide such other traffic control necessary to achieve the required standards. This includes the erection of additional barricades, lights, warning notices or traffic control signs including, where necessary, the provision of staff to control traffic.
- 8.4.8.9 Failure by the operator to provide adequate safety measures may result in a work suspension notice being issued by the Council, until such time as adequate control is provided.
- 8.4.8.10 The position of existing watermains, sewers and other services or structures above or below ground, as far as they are known, are available for the information of the operator at the offices of the Council and respective Service Authorities, but their positions are not guaranteed.
- 8.4.8.11 Limit lines must be replaced when trafficked, but can be a temporary marking for the first five days.
- 8.4.8.12 Trenchless technology may be preferable for alignments passing through or under:
 - a) Environmentally sensitive areas;
 - b) Built-up or congested areas to minimise disruption and reinstatement or major road crossings;
 - c) Significant vegetation;

- d) Vehicle crossings and areas with high quality paving surface exist.

8.4.8.13 Where there is a large number of existing services the following details including location of access pits and exit points will be submitted to the Engineering Manager for approval:

- a) Clearances from services and obstructions;
- b) The depth at which the pipeline is to be laid to ensure minimum cover is maintained;
- c) The pipe support and ground compaction;
- d) How pipes will be protected from damage during construction;
- e) Any assessed risk to abutting surface and underground structures.

8.4.8.14 See Section 6.10 of the Wastewater section for further details on trenchless technology.

8.4.8.15 Special conditions when working near traffic signals may be imposed by the Council to protect the detector loops and the operation of the signals, see Section 8.4.6.11.

8.4.8.16 Branches that require removal should be cut by saw and not broken by machinery.

8.5 Excavation

This section deals with excavation, back filling, and surface re-instatement.

Mandatory Matters

Council requires the following standards to be met in all excavation and re-instatement works:

8.5.1 General

8.5.1.1 The backfilling of excavations will be undertaken in accordance with SD801 and SD803 using imported backfill material that comply with New Zealand Transport Agency specifications.

8.5.1.2 Basecourse used in the Pavement section of the backfill will be to New Zealand Transport Agency (TNZ) M/4 Specifications.

8.5.1.3 The material used for bedding underneath and around the service or service duct will be as required in Chapter, 7, Section 7.8.6.

8.5.1.4 Surface reinstatement (including the final or temporary sealing) will be completed prior to vehicle and pedestrian traffic being permitted to use the surface. In all other situations, surface reinstatement will be completed within five days of the trench being opened or such other period as directed by the Council.

8.5.1.5 Variation from this condition will require the written agreement of the Council. For works within the CBD or Arterial Roads, surface reinstatement will be completed within 24 hours of the trench being opened or such other period as directed by the Council.

8.5.1.6 Failure to complete reinstatement within the specified period may result in Council arranging reinstatement at the operator's expense.

- 8.5.1.7 All excavations will be backfilled, as detailed on SD801, SD802 and SD803 to the underside of the proposed wearing surface, or to the finished level if permanent reinstatement is not being undertaken immediately. This temporary over filling will be removed when permanent reinstatement is carried out.
- 8.5.1.8 If permanent reinstatement cannot be undertaken immediately, in areas to be reopened for vehicle or pedestrian use, the operator will arrange for a 10mm thick layer of fine 'Cold Mix' or a rubberised pre-fabricated chip seal with 100mm over lap laid to manufacturer's instructions to be applied to the trench immediately backfilling is completed.
- 8.5.1.9 Where work is required within an area that has been re-surfaced within the last two years an alternative route must be identified. If this is not possible then, depending on the position and nature of the excavation, a full width reinstatement may be required. Where a full width reinstatement is required, then the length of the reinstatement will be not less than the width of the carriageway (or footpath).
- 8.5.1.10 All temporary markings to locate services will be removed on completion of the works.
- 8.5.1.11 All parts of the surface damaged during or as a result of the work will be reinstated to maintain the cross-fall slope. Finished levels will be compatible with the existing pavement.
- 8.5.1.12 All permanent surface reinstatement and sealed surface on carriageways will be completed as shown on SD801, SD802, SD803 and SD806, with the finished wearing surface depth, matching that of the existing road and finishing flush with or no more than 5mm above the existing surface.
- 8.5.1.13 Excavations (including the final saw cut edge) that are closer than 1.0m horizontal to the existing edge of the seal, kerb and channel, previous excavation reinstatement, or joint will have a reinstated sealed surface that extends to join with the existing edge of seal, kerb and channel or adjacent reinstatement.
- 8.5.1.14 Subject to favourable weather conditions, an appropriate Polymer Modified Bandage (PMB) 100mm wide by 1.5mm thick, will be completed within five days of resurfacing.
- 8.5.1.15 On unsealed rural roads and metal shoulders backfilling will be as for chip sealed carriageways with 50mm of top course being placed as the final reinstatement. Finished levels will be compatible with the existing pavement.
- 8.5.1.16 Service boxes, for example; water hydrant boxes, manholes etc will be installed in their final location during trench compaction and their finished level will be finished flush with or no more than 5mm above the reinstated pavement surface. All service boxes and lids will be raised and adjusted to final level prior to placement of surfacing seal coat.
- 8.5.1.17 For State Highways, refer to New Zealand Transport Agency requirements.

8.5.2 Footpath Reinstatement

- 8.5.2.1 All permanent surface reinstatement on footpaths will be completed as shown on SD803-SD806 with a finished surface matching the existing and finishing flush with the existing surface. The minimum dimension of any reinstated portion of the footpath will not be less than 600mm wide.
- 8.5.2.2 The width of remaining undamaged footpath will not be less than 1.0m. (See SD803). If these criteria cannot be met the reinstatement will be across the full width of the footpath. Also, the full

width of the footpath will be replaced when trenching in footpaths within the Nelson Central City, Stoke, Richmond, Motueka and Takaka Centre areas, or Arterial, and Principal roads or new footpaths with a sealed surface less than two years old.

- 8.5.2.3 Vehicle crossings which are affected by the work will be reinstated with a minimum of 150mm thick concrete for residential crossings, 200mm thick concrete for commercial crossings, while industrial crossings are to match existing with a minimum of 300mm thick concrete. Concrete for commercial and industrial entrance slabs will be reinforced with 665 WWF (see SD409).
- 8.5.2.4 Note: In asphaltic concrete and chip sealed footpaths the depth of basecourse at vehicle crossings will match the depth of the existing basecourse, with a minimum depth of 300mm for industrial crossings, 200mm for commercial and 150mm for residential crossings.
- 8.5.2.5 With interlocking pavers, the blocks removed during excavation or new blocks of identical shape, thickness and colour will be replaced on a subgrade similar to that in adjoining undisturbed areas and compacted and filled to give a true surface in accordance with NZS3116.
- 8.5.2.6 All paving work will be carried out by staff competent in this work. Gaps between blocks shall be 2-3mm. Jointing sand will be 'Pavelock' or similar approved sand. A neoprene sheet will be used to protect blocks when a plate compactor is used. The minimum size of part blocks used will be a half block.

8.5.3 Berms and Shoulders

- 8.5.3.1 Surface reinstatement to grassed berms and shoulders will be completed as per Chapter 4, Sections 4.15.2.4 to 4.15.2.7.
- 8.5.3.2 Full reinstatement will be achieved within 48 hours with screened topsoil being raked into all cut joints, with all turfs being adequately watered immediately following completion of reinstatement.

Good Practice

The following matters provide additional guidance and direction in all excavation works.

- 8.5.3.3 If 'Cold Mix' is not available a temporary seal of sprayed Emulsion and Grade 5 or 6 chip may be substituted with the approval of the Council. This is to be regarded as a temporary seal only and will be removed before the permanent resurfacing of the trench is carried out. The operator will maintain this surface, even and free draining, until the final restoration is complete. The cost of all temporary resurfacing and subsequent removal will be borne by the operator.
- 8.5.3.4 Patching of small areas of permanent surfacing, such as service boxes, may be permitted by Council).
- 8.5.3.5 Regarding the reinstatement of grassed berms, turfs may be cut from the berm 75mm in thickness and 50mm wider than the trench and stacked for re-use. Full reinstatement of this solution will be achieved within 48 hours with screened top soil being raked into all cut joints, with all turfs being adequately watered immediately following completion of reinstatement.
- 8.5.3.6 Alternative surface dressings may be used with the Corridor Manager's approval (see Chapter 4 Transportation).

8.6 Subsoil drainage

This section deals with the use, design and construction of sub-soil drains.

Mandatory Matters

Council requires the following standards to be met where sub-soil drains are used:

- 8.6.1.1 Geotechnical assessments will be carried out by a geotechnical professional whenever the situations stated in NZS4404 Clause 2.1 are present.
- 8.6.1.2 The geotechnical professional will carry out the functions listed in NZS4404 Clause 2.2.4, as well as the following:
- a) Provide Geotechnical Report, including Site Investigation, Interpretation and Analysis;
 - b) Incorporate and describe how Engineering Redundancy is achieved within the design;
 - c) Demonstrate engineering redundancy via a Quantitative Slope Stability Analysis.
- 8.6.1.3 A risk review will be undertaken by the geotechnical professional and will be recorded as a risk register. The risk review will include:
- a) Compiling a list of geo-hazards present at the site;
 - b) Compiling a list of risks to the sub soil drainage system (such as geo-hazards, tree roots, post construction, directional drilling, construction errors, vandalism, future infrastructure for example; house foundations, retaining wall foundations etc) and listing proposed mitigation techniques (such as subsoil drainage zones, limits of deep foundations, application of contingency designs (directional drilling);
 - c) Assessing the impact of a worst-case slope failure which considers risk to the private properties, council infrastructure and adjoining properties.
- 8.6.1.4 Type A Subsoil drains are defined as subsoil drains that are an integral part of the mass earthworks, and the Geotechnical Certification is subject to these drains remaining in good working order at all times and operating as designed.
- 8.6.1.5 Type-A Subsoil Drains will not be permitted in Nelson or Tasman regions either as a public or private asset.
- 8.6.1.6 Type B subsoil drains are defined as subsoil drains that are a requirement of the earthworks design and construction, but the guaranteed ongoing operation of these drains is not required for ongoing land stability and there is no requirement by the certifying Geotechnical Engineer that these drains need to be monitored and maintained.
- 8.6.1.7 Council will not accept these drains as a vested asset pursuant to any development of private land.
- 8.6.1.8 Subsoil drains must be designed and constructed in a way that allows them to be inspected internally using CCTV. This will be undertaken after trench backfill is completed but prior to major earthworks, and the information including video and a short report provided to the Council.
- 8.6.1.9 Prior to 224 certification, subsoil drains are to be inspected by CCTV and that CCTV inspection is to be reviewed by the certifying Geotechnical Engineer and certified as acceptable.

- 8.6.1.10 Prior to 224 certification, Geotechnical Certification must be provided to Council by the certifying Geotechnical Engineer confirming that the subsoil drains are not required as a means of instability risk management. Geotechnical Certification must be made by a suitably qualified Chartered Professional Engineer.
- 8.6.1.11 Prior to 224 certification, As-Built plans for the entire subsoil drain system will be provided to Council, detailing the surveyed alignment and depth to finished ground levels for the entire subsoil drain system.
- 8.6.1.12 Prior to 224 certification, subsoil drains must be legally protected (for example; through easement) from being built or constructed over, including appropriate requirements, detailed by the certifying Geotechnical Engineer, if building adjacent or over the subsoil drains is anticipated.

Good Practice

The following matters provide additional guidance and direction in all subsoil drainage activities.

- 8.6.1.13 Consideration should be given to avoiding disturbance of wet areas. Wet areas should be assessed during the concept and design phase to ensure they are not flood flow paths, intermittent waterways or wetlands.
- 8.6.1.14 Subsoil drainage will generally be required for significant areas of fill. More extensive sub-soil drains may be necessary on flatter ground in wet areas.
- 8.6.1.15 Sub-soil drains are discouraged under proposed building envelopes as they may be damaged in piling or excavations for the future dwelling.
- 8.6.1.16 The certifying Geotechnical Engineer may rely on ongoing monitoring and maintenance requirements over the life of the drain.

PMB BANDAGE 100mm WIDE 1.5mm THICK

NEW FRICTION COURSE * NZTA M/10 DG7, 30mm DEPTH

SAW CUT

WATERPROOF SEAL COAT ON TOP OF BASECOURSE

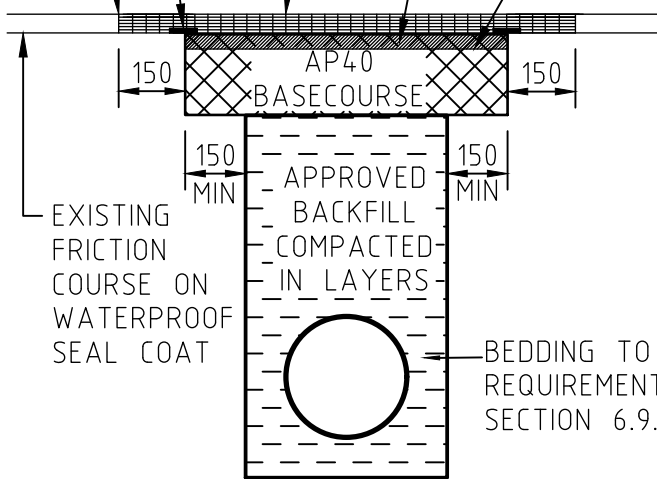

FOR FRICTION COURSE

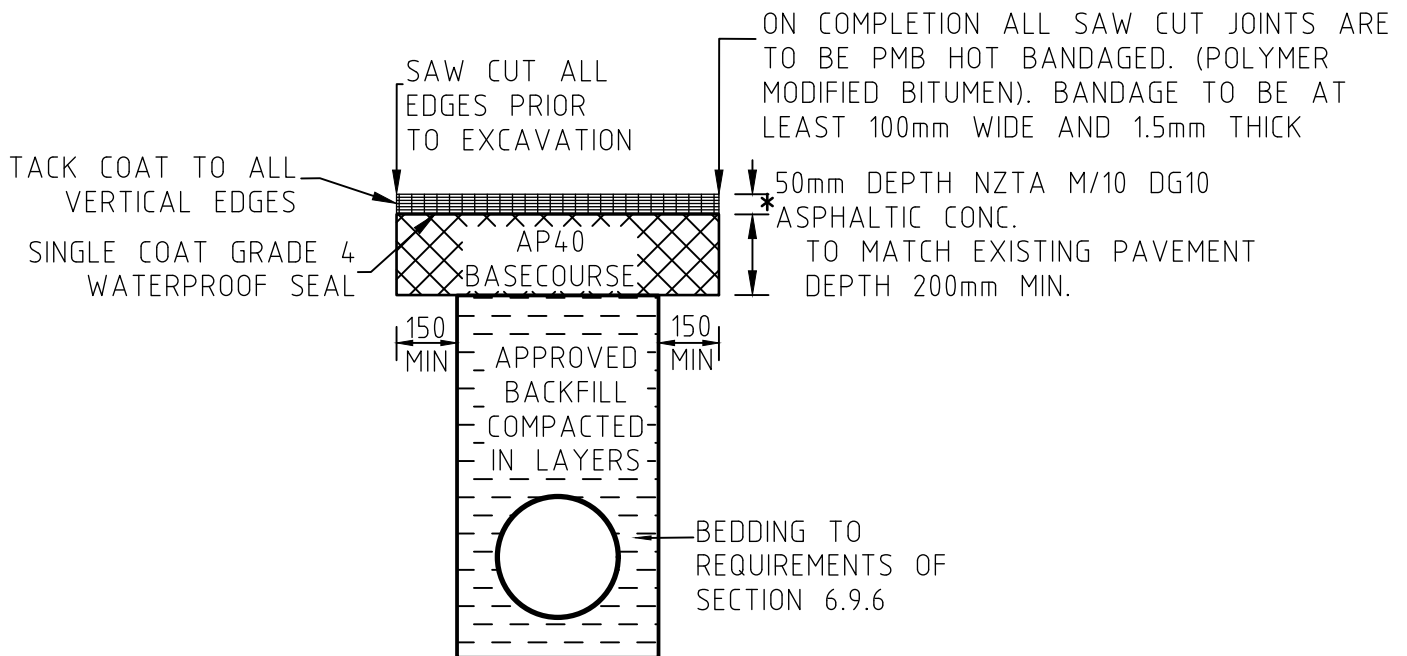

FOR CHIP SEAL, THIN ASPHALT & DEEP ASPHALT

NOTES

1. UNSEALED ROADS & SHOULDERS. REINSTATEMENT TO BE 150MM DEPTH OF 40MM BASECOURSE TOPPED OFF WITH 50MM DEPTH OF 20MM BASECOURSE
2. FOR FINISHED SEAL LEVEL TOLERANCES SEE SECTION 8.4.8 & 4.18.5
3. *DEPTH TO MATCH EXISTING BITUMINOUS LAYER DEPTH, WHERE DEPTH IS GREATER THAN 50mm

NELSON CITY COUNCIL

 GROUP MANAGER INFRASTRUCTURE, NELSON

TRENCH REINSTATEMENT
 IN CARRIAGEWAY

TASMAN DISTRICT COUNCIL

 ENGINEERING SERVICES MANAGER, TASMAN

DATE
 01/07/19

NELSON - TASMAN
 LAND DEVELOPMENT MANUAL

801

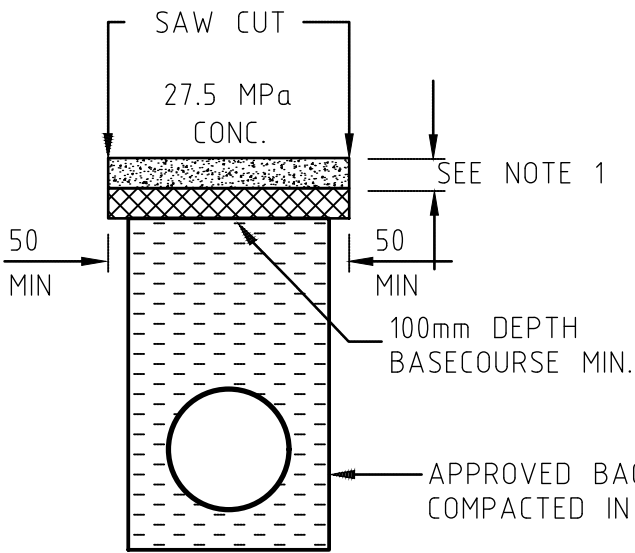

CONCRETE

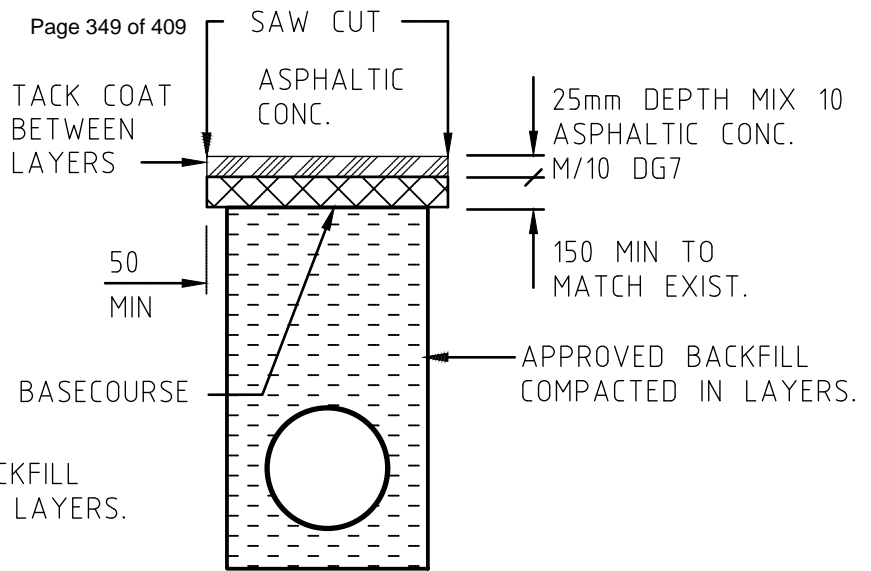

THIN ASPHALTIC
(FOR CHIP SEAL FOOTPATHS ALSO)

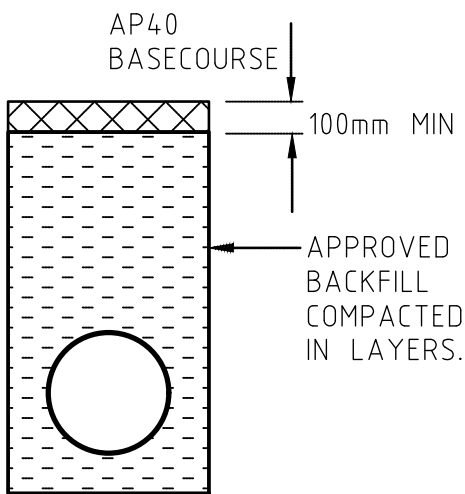

GRAVEL

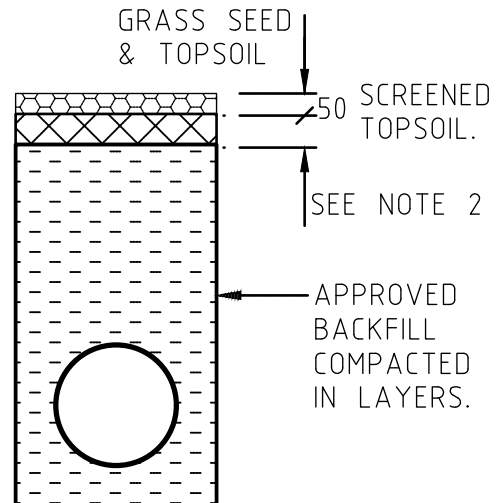

GRASS

NOTES

1. 100mm FOR FOOTPATH. 150mm FOR RESIDENTIAL CROSSING. 200mm FOR COMMERCIAL CROSSING WITH 665 MESH. FOR INDUSTRIAL CROSSING PAVEMENT TO SPECIFIC DESIGN (TO MATCH EXISTING).
2. UNSCREENED TOPSOIL (50mm FOR CLAY FILLS, 100mm FOR GRAVEL OR SAND FILLS).

<p>NELSON CITY COUNCIL</p> <p><i>[Signature]</i></p> <p>GROUP MANAGER INFRASTRUCTURE, NELSON</p>		<p>TRENCH REINSTATEMENT IN FOOTPATH</p>	
<p>TASMAN DISTRICT COUNCIL</p> <p><i>[Signature]</i></p> <p>ENGINEERING SERVICES MANAGER, TASMAN</p>	<p>DATE</p> <p>01/07/19</p>	<p>NELSON - TASMAN LAND DEVELOPMENT MANUAL</p>	<p>802</p>

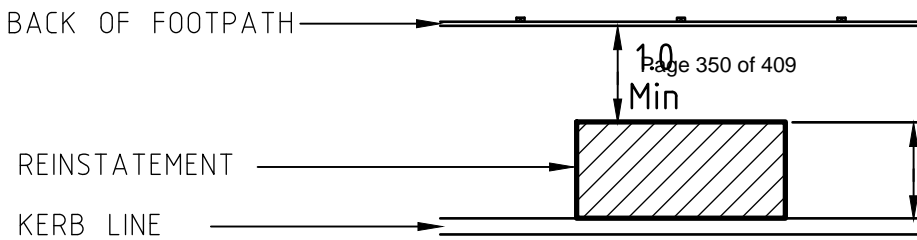

APPROVED

(EXCLUDING ARTERIAL & PRINCIPAL ROADS & CBD AREAS OR FOOTPATH SURFACES LESS THAN 5 YEARS OLD)

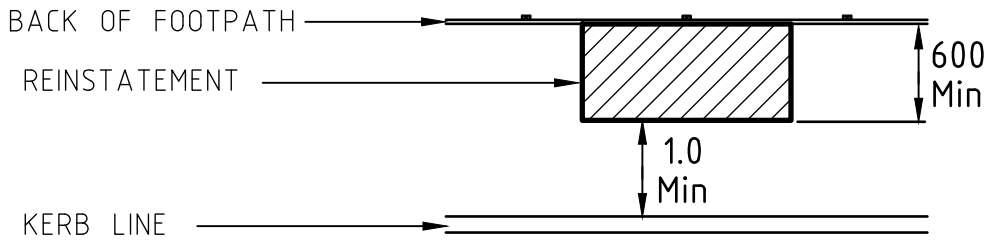

APPROVED

(EXCLUDING ARTERIAL & PRINCIPAL ROADS & CBD AREAS OR FOOTPATH SURFACES LESS THAN 2 YEARS OLD)

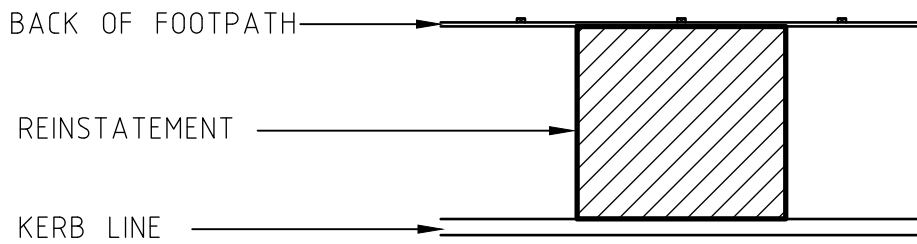

APPROVED

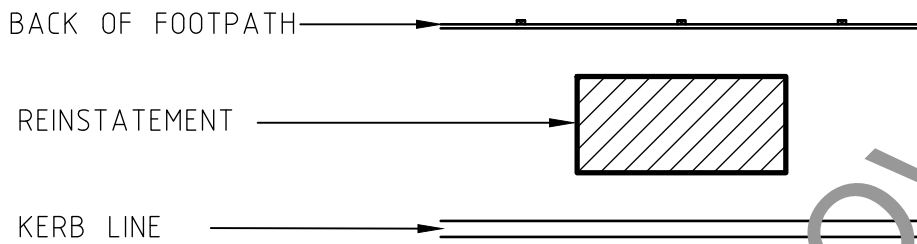

NOT APPROVED

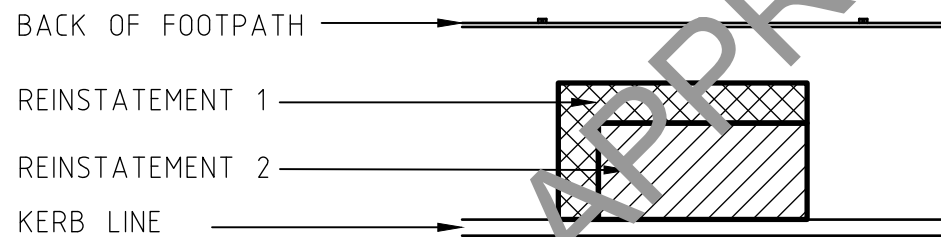

NOT APPROVED

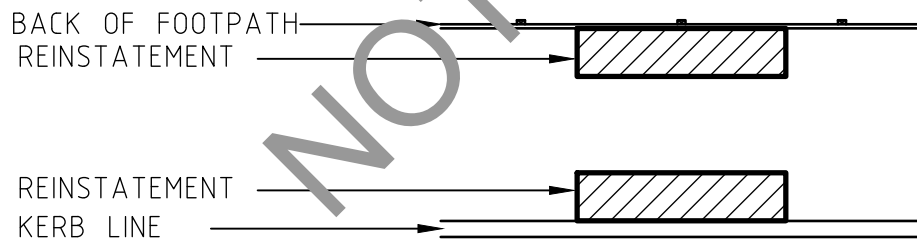

NOT APPROVED

NOT APPROVED

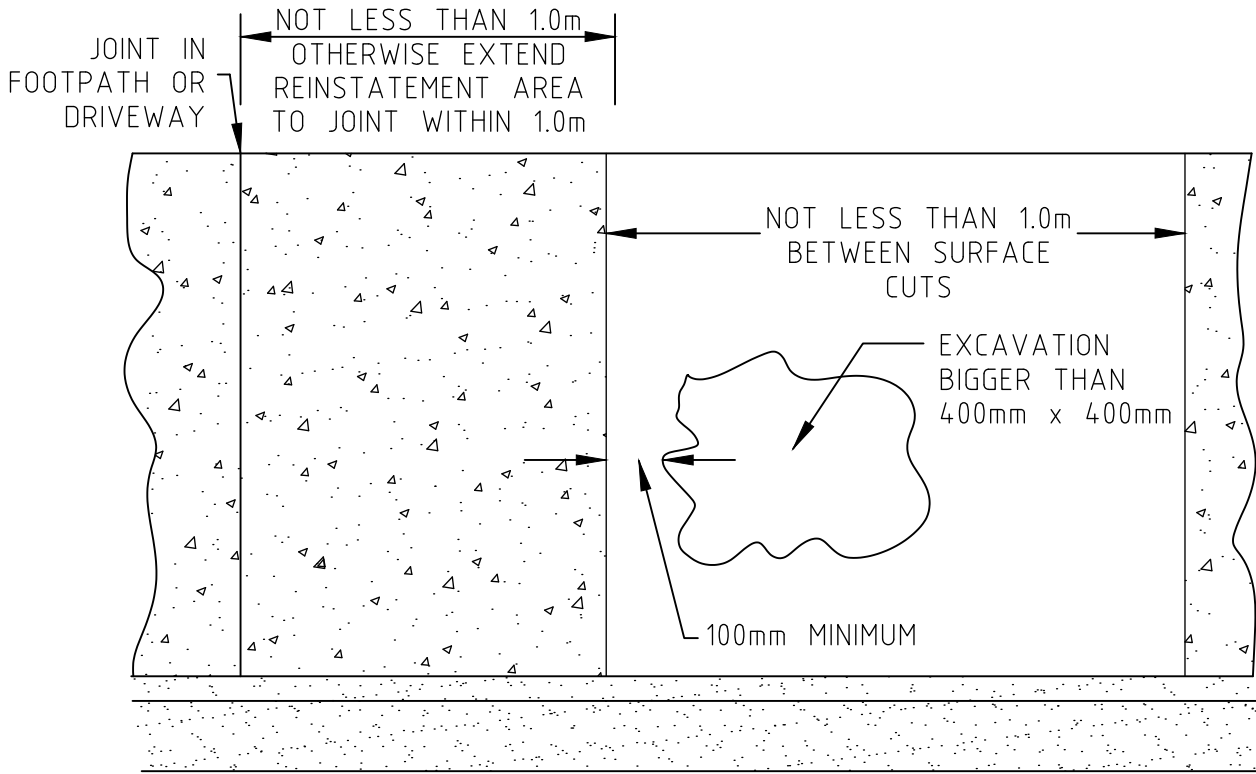

<p>NELSON CITY COUNCIL</p> <p>GROUP MANAGER INFRASTRUCTURE, NELSON</p>	<p>FOOTPATH SURFACE REINSTATEMENT</p>		
<p>TASMAN DISTRICT COUNCIL</p> <p>ENGINEERING SERVICES MANAGER, TASMAN</p>	<p>DATE</p> <p>01/07/19</p>	<p>NELSON - TASMAN</p> <p>LAND DEVELOPMENT MANUAL</p>	<p>803</p>

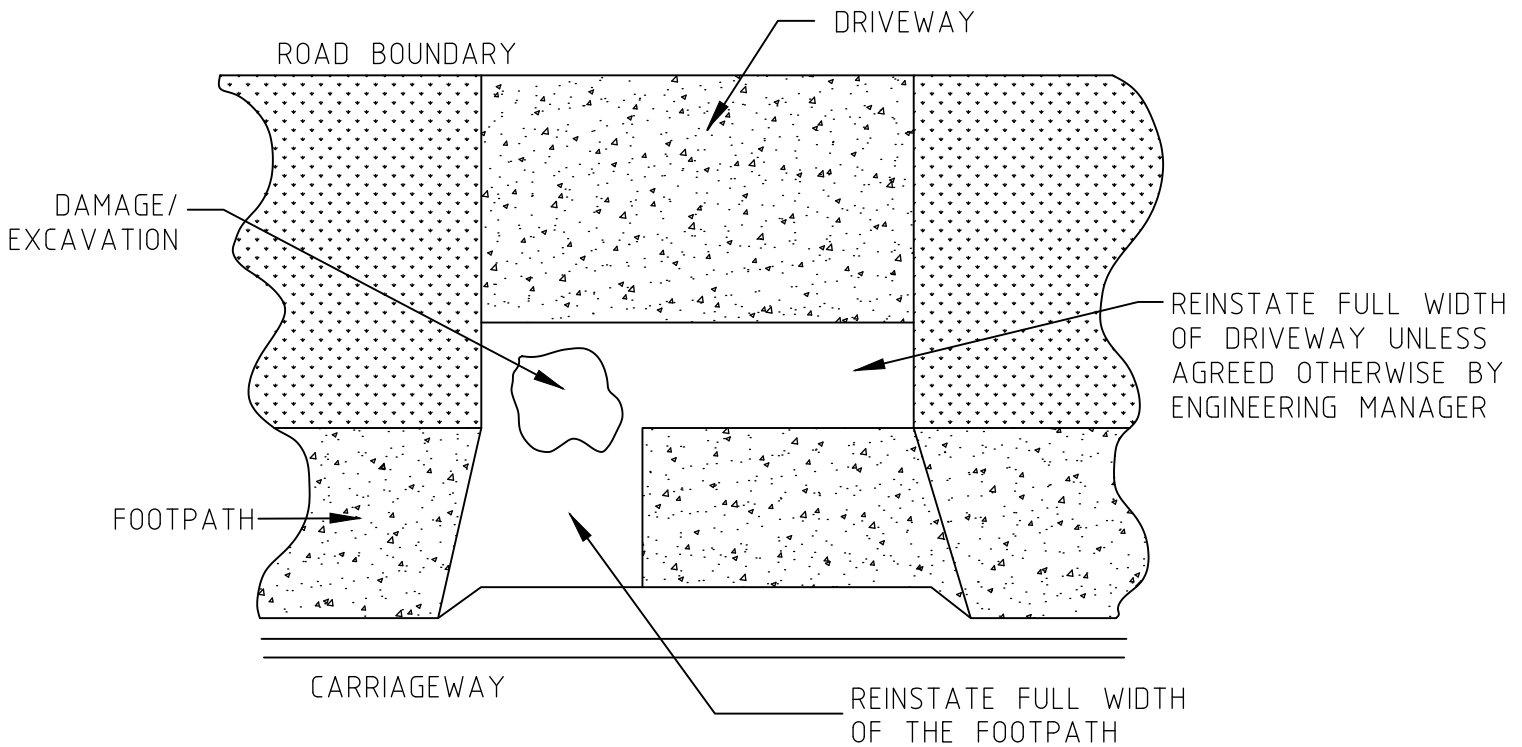

REINSTATEMENT OF CONCRETE PATH OR DRIVEWAY



EXCAVATION IN FOOTPATH OR DRIVEWAY

NELSON CITY COUNCIL  GROUP MANAGER INFRASTRUCTURE, NELSON		FOOTPATH SURFACE REINSTATEMENT	
TASMAN DISTRICT COUNCIL  ENGINEERING SERVICES MANAGER, TASMAN	DATE 01/07/19	NELSON - TASMAN LAND DEVELOPMENT MANUAL	804

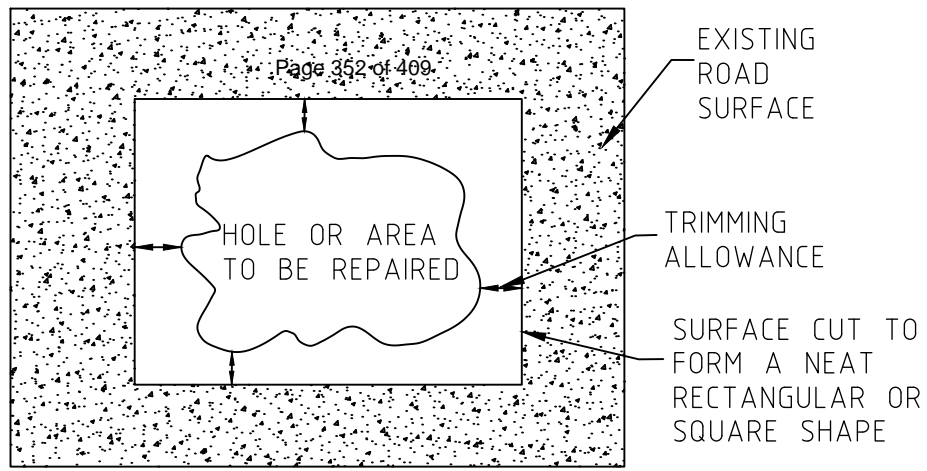

**FIG 1 - FINISHING OF IRREGULAR SHAPED EXCAVATIONS
PLAN VIEW**

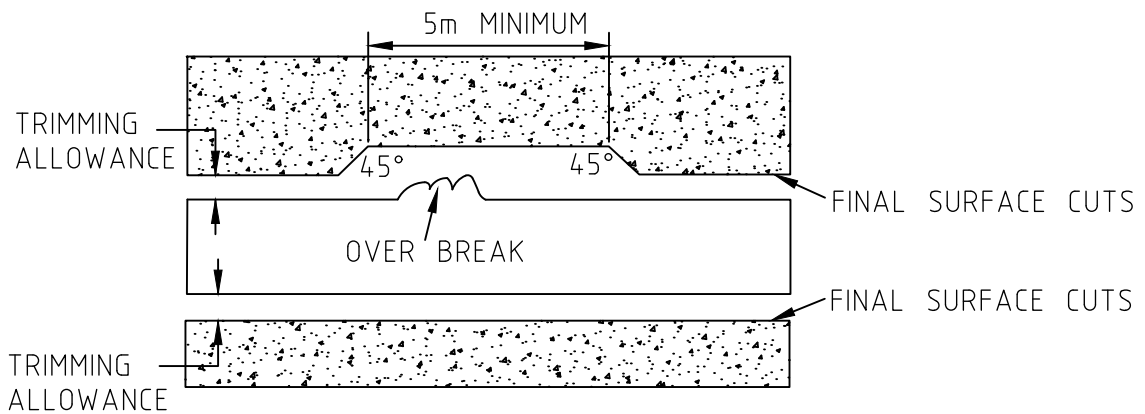



**FIG 2 - PARALLEL CUTTING OF JOINTS
PLAN VIEW**

NOTES

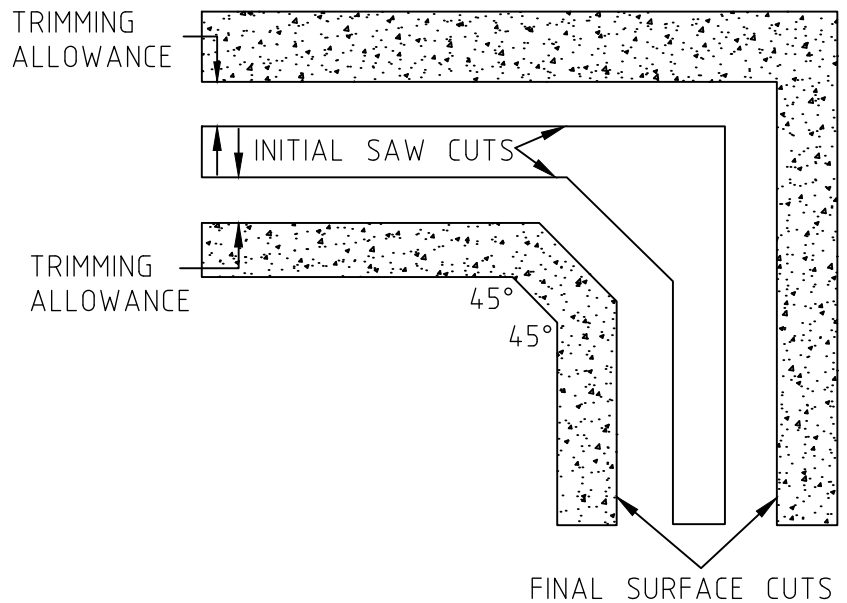
1. A MINIMUM TRIMMING ALLOWANCE OF 150mm
2. TOTAL LENGTH OF OVER BREAK OF THE TRENCH MUST NOT EXCEED 10% OF ITS LENGTH. THE LENGTH OF TRIM AT ANY SINGLE SECTION OF OVER BREAK SHOULD NOT BE LESS THAN 5m (SEE FIG. 2). THE PURPOSE OF THESE REQUIREMENTS IS TO AVOID AN UNDESIRABLE VISUAL IMPACT.



**FIG 3 - TRENCH EXCAVATION WITH CORNERS
PLAN VIEW**

NELSON CITY COUNCIL  GROUP MANAGER INFRASTRUCTURE, NELSON		SURFACE REINSTATEMENT TRIMMING ALLOWANCE	
TASMAN DISTRICT COUNCIL  ENGINEERING SERVICES MANAGER, TASMAN	DATE 01/07/19	NELSON - TASMAN LAND DEVELOPMENT MANUAL	805

METHOD 1 - THE "PEEL BACK" METHOD

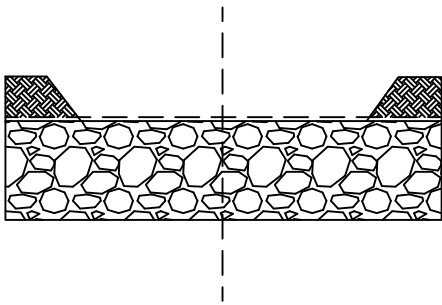

CAREFULLY REMOVE FILL TO EXPOSE GEOGRID AND CUT THE GROUND AT THE PIPE CENTRELINE

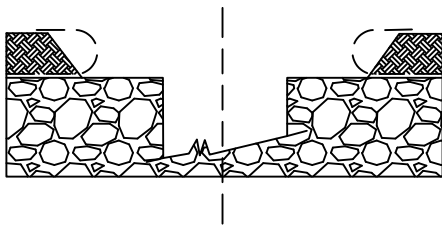

ROLL BACK THE GEOGRID TO EACH SIDE TO ENABLE THE EXCAVATION

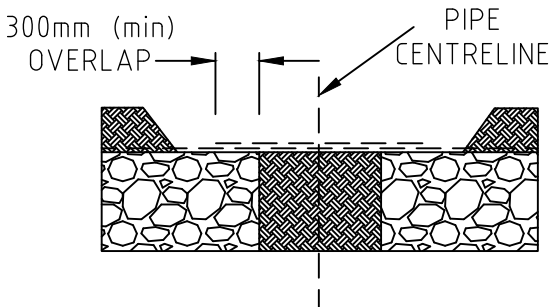

UPON BACKFILLING THE TRENCH EXCAVATION, RELOCATE THE GEOGRIDS AND PLACE A 600mm (min) SEALING STRIP OF GEOGRID. REPLACE THE FILL

METHOD 2 - THE "DIG THROUGH" METHOD

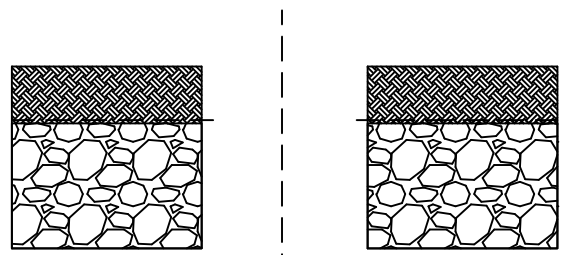

EXCAVATE TRENCH AND BREAK THROUGH THE GEOGRID

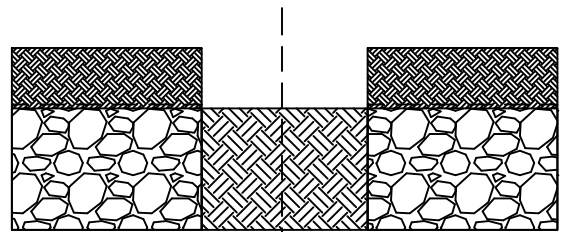

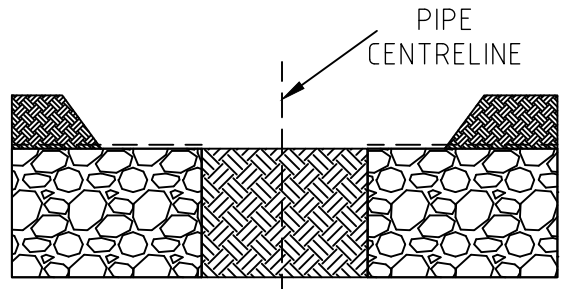

BACKFILL TRENCH TO GEOGRID LEVEL

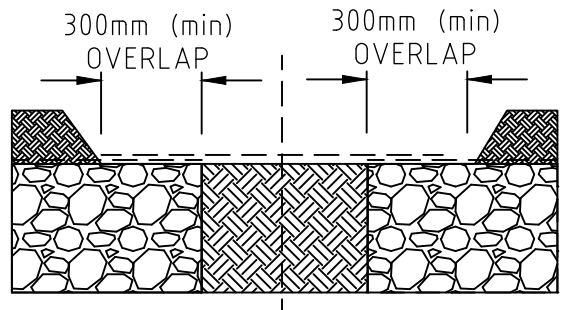

TRIM BACK THE FILL TO EXPOSE 300mm OF GEOGRID

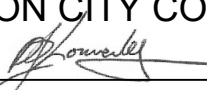

PLACE SEALING STRIP of GEOGRID. REPLACE THE FILL.

<p>NELSON CITY COUNCIL</p>  <p>GROUP MANAGER INFRASTRUCTURE, NELSON</p>		<p>REINSTATING BIAXIAL GEOGRIDS FOLLOWING TRENCH EXCAVATIONS</p>	
<p>TASMAN DISTRICT COUNCIL</p>  <p>ENGINEERING SERVICES MANAGER, TASMAN</p>		<p>DATE</p> <p>01/07/19</p>	<p>NELSON - TASMAN LAND DEVELOPMENT MANUAL</p>
			<p>806</p>



Chapter 9

Telecommunications, Electrical and Streetlighting

TABLE OF CONTENTS

CHAPTER 9	TELECOMMUNICATIONS, ELECTRICAL AND STREETLIGHTING	1
INTRODUCTION		1
9	PURPOSE	1
9.1	Performance Outcomes.....	1
	Mandatory Matters	1
9.2	Referenced Documents	1
9.2.1	District Plan Requirements	1
9.2.2	External Standards	2
	Mandatory Matters	2
9.3	Cable Protection.....	3
	Mandatory Matters	3
9.4	Pipe and Duct Installation	3
	Mandatory Matters	3
9.5	Access Points.....	4
	Mandatory Matters	4
9.6	Approvals and Records.....	4
	Mandatory Matters	4
	Good Practice.....	4
9.7	Electrical Reticulation Design.....	5
	Mandatory Matters	5
9.7.1	General	5
9.7.2	Design.....	5
9.7.3	Location and Capacity	6
9.7.4	Records.....	7
	Good Practice.....	7
9.8	Electrical Reticulation, Easements and Subdivision	7
	Mandatory Matters	7
9.8.2	Broadband Speed.....	8
9.9	Easements	8
9.10	Rural Areas	8
	Good Practice.....	9
9.10.2	General	9
9.10.3	Rural locations	9
9.10.4	Private Access	10
9.11	Cabling, Ducting and Service Boxes	10
	Mandatory Matters	10
9.11.1	General	10
9.11.2	Substations	11
9.11.3	Approvals and Records	11
9.11.4	Protection.....	12

Good Practice.....	13
9.12 Streetlighting	13
Mandatory Matters	13
9.12.1 General	13
9.12.2 Luminaires	14
9.12.3 Columns.....	15
Good Practice.....	17
9.12.4 General	17
9.12.5 Columns.....	17
9.12.6 Reserves and Carparks	17

APPENDICES

Appendix A Nelson/Tasman Council Street Light Data Collection Form

LIST OF TABLES

Table 9-1 Streetlight Networks Standards	2
Table 9-2 Minimum Separations Between Power and Telecommunications Cables	12

CHAPTER 9 TELECOMMUNICATIONS, ELECTRICAL AND STREETLIGHTING

INTRODUCTION

9 PURPOSE

The purpose of this section sets out the information that the Council requires to ensure that telecommunications, electricity and street lighting networks are designed and installed to meet community expectations for power, lighting and communications.

The standards also seek to ensure that physical and legal access to all underground services is ensured with a minimum of disruption, and that networks are durable and affordable.

9.1 Performance Outcomes

Mandatory Matters

Telecommunications utilities performance outcomes sought by these standards are as follows:

- a) All new underground cabling and surface infrastructure meets the needs of people and communities for electricity, streetlighting and telecommunications;
- b) All new cabling is located within public land, or is legally and physically protected where it is located on private property;
- c) Legal and physical access to underground cabling is ensured for ease of repairs and maintenance, with a minimum of disturbance;
- d) The location of all telecommunication services is clearly marked;
- e) Cables and underground networks are installed with a minimum of disruption;
- f) Streetlighting has been provided to ensure personal and traffic safety;
- g) All surface infrastructure including streetlights is in keeping with the amenity and character of the environment;
- h) All underground cabling and surface infrastructure associated with telecommunications, streetlighting and electricity is robust, durable and safe.

9.2 Referenced Documents

9.2.1 District Plan Requirements

The standards set out in this chapter address matters that are specific to the Council asset creation or activities that may have an impact on an asset. They are subject to the Nelson City and Tasman District Resource Management Plans (RMP's).

9.2.2 External Standards

Mandatory Matters

Unless otherwise specified within the standards of this document, telecommunications, electrical and streetlighting networks shall be designed and constructed in a manner consistent with standards set out in Table 9-1. Where an Act or National Standard document is referenced, this shall be the current version including any associated amendments.

Table 9-1 Streetlight Networks Standards

Standard / Reference	Description
AS/NZS 1158.0	Road lighting – Introduction
AS/NZS 1158.1	Road lighting – Vehicular traffic (Category V) lighting – Performance and design requirements
AS/NZS 1158.1.2	Road lighting – Vehicular traffic (Category V) lighting – Guide to design, installation, operation and maintenance
AS/NZS 1158.2	Road lighting – computer procedures for the calculation of light technical parameters for Category V and Category P lighting
AS/NZS 1158.3.1	Road lighting – Pedestrian area (Category P) lighting – Performance and design requirements
AS/NZS 1158.4	Lighting for Roads and Public Spaces – Lighting of pedestrian crossings
AS/NZS 1158.5	Lighting for Roads and Public Spaces – Tunnels and underpasses
SA/SNZ TS 1158.6	Lighting for roads and public spaces – Part 6 Luminaires – Performance
AS/NZ S3000	Electrical installations (Australian/New Zealand wiring rules)
AS/NZ S4065	Concrete utility services poles
AS/NZS 4676	Structural design requirements for utility services poles
AS/NZS 4677	Steel utility services poles
AS/NZS 4680	Hot-dip galvanized (zinc) coatings on fabricated ferrous articles
AS 4702	Polymeric cable protection covers
New Zealand Legislation – Electricity Act 1992	Electrical safety regulations 2009 Design of reticulation
NZ Electricity Code of Practice	Current and voltage ratings
Line Owner	Design and Construct and Distribution Codes

9.3 Cable Protection

Mandatory Matters

- 9.3.1.1 Protection shall take the form of either:
- 50mm thick non-metallic reinforced concrete slabs (usually 150mm wide and 500mm long); or
 - 100mm x 50mm ground retention treated timber with a minimum specification of the New Zealand Timber Preservation Council classification; or
 - 5mm polymeric cable cover.
- 9.3.1.2 The depth and offset of trenches specified on the laying plan provided by the network line operator must be maintained.
- 9.3.1.3 Minimum cover shall be 450mm in footways and 600mm in roadways.
- 9.3.1.4 Appropriate mechanical protection shall be provided for any underground telecommunication reticulation in accordance with the network operator's requirements.

9.4 Pipe and Duct Installation

Mandatory Matters

- 9.4.1.1 All services crossing the proposed duct pipe route shall be exposed and the necessary clearances maintained to enable the network line operator's ducts to be installed either above or below these other services. The network line operator's ducts shall be laid above power cables.
- 9.4.1.2 All joints in duct pipe shall be water tight.
- 9.4.1.3 The base of the trench shall be level with large objects removed. The duct pipe shall be bedded in accordance with Chapter 7, Section 7.8.2.
- 9.4.1.4 Adequate provision shall be made for draining cable/ducting trenches in accordance with Chapter 7 of the Nelson Tasman Land Development Manual.
- 9.4.1.5 Cable and duct locations in the road reserve area shall be in general accordance with SD901, SD902, SD412 and SD413.
- 9.4.1.6 Cable and duct locations down rights-of-way shall:
- Be located 750mm from a boundary in a berm area where provided; or
 - Be at the centre of the right-of-way; and
 - Be at a depth 450-600mm; and
 - Where located in a common trench with water and power services, be in accordance with SD902.
- 9.4.1.7 Where telecommunication reticulation cables are on private property (excluding rights-of-way):
- Visible 'above ground' warning markers shall be placed where cables change direction; and;

- g) In between not more than 10m spacing in all but rural areas where the minimum spacing shall be not more than 20m; and
- h) Warning markers shall be as stated in the network operator's design and construction standards.

9.4.1.8 Road crossings for telecommunication reticulation cables shall be in PVC ducts to the network operator's requirement at a minimum depth of 450-600mm.

9.5 Access Points

Mandatory Matters

- 9.5.1.1 The pits and lids are designed to withstand light vehicular loading only. Therefore, installation shall only take place in the footpath or in grassed areas within the defined kerb network. On mountable kerbs they shall be located in grass areas and behind the footpath.
- 9.5.1.2 The grass berm or footpath shall be excavated to a sufficient depth to ensure that the pit lid will be level with the finished level of the surface.
- 9.5.1.3 Service pillars shall be set back close to section boundaries and are to be clear of designated vehicular access and pedestrian ways by a minimum of one metre.
- 9.5.1.4 The minimum spacing of any service pillars from any boundary line or survey peg shall be 200mm so as to enable future fencing construction.

9.6 Approvals and Records

Mandatory Matters

- 9.6.1.1 Any ducting systems installed in the road reserve area shall be considered as part of the telecommunication reticulation system for the purpose of 'as-built' records.
- 9.6.1.2 Any excavation within the existing road reserve is subject to the Councils' approval and a work approval notice issued by the Council.

Good Practice

The following matters provide additional direction and guidance in the installation of Telecommunications Utilities:

- 9.6.1.3 Where multiple driveways on lot boundaries make it impractical to position a service pillar at a common boundary between lots or, where a narrow road frontage width of a lot makes the location of a service pillar vulnerable to damage, it is permissible to install a duct in the road reserve from a lot boundary to a service pillar with an offset of no more than 10m from the affected lot. This is the only occasion service leads are to be run along road reserve.

9.7 Electrical Reticulation Design

This section outlines general design requirements for all electrical utilities.

Mandatory Matters

The Council requires the following standards to be met in the provision of electrical utilities.

9.7.1 General

- 9.7.1.1 All new service mains will be by underground cabling in “rural areas” or as approved by the Council and the utility operator.
- 9.7.1.2 Reinforcement or replacement of existing overhead works will be by underground cabling apart from specific exemption from the Council. This will not exclude the line owner carrying out any maintenance (replacement or upgrade) of existing works as long as the land will not be injuriously affected as a result of the maintenance (replacement or upgrade).
- 9.7.1.3 Any variations (exceptional circumstances) given by either the line owner (for variation from its own electrical design and construction standards) or the Council (for variation from its Land Development Manual) will be in writing and shall indicate which section and subsection of the relevant standards the variation applies to.
- 9.7.1.4 Existing allotments with no “power to the boundary” and requiring an electrical supply will be by underground cabling.
- 9.7.1.5 All works assets to be vested with the line owner or electricity operator will meet their respective design and construction standards and distribution code.
- 9.7.1.6 Any underground or overhead works cable being vested with the electricity operator and installed on any titled land will be secured by way of an easement in favour of the line owner. See Section 9.9.
- 9.7.1.7 Service main exclusive fittings owned by a third party will also have private easements registered outside the point of supply if the route crosses titled land not owned by the third party. See Section 9.11.
- 9.7.1.8 Where a boundary is adjusted enabling a lot to contain an installation the Council will require confirmation from the line owner that the existing works are sufficient to supply another installation as required.
- 9.7.1.9 Designers are to liaise with other service authorities to achieve economical use of the road reserve area with due consideration given to ease of maintenance to the works system and other services in the road reserve area.

9.7.2 Design

- 9.7.2.1 All new works and service mains will be by underground cabling in urban areas.
- 9.7.2.2 The design of the works shall, as a minimum requirement, comply with the current Electricity Regulations and the requirements and standards of the line owner.

- 9.7.2.3 The design of the works shall give consideration to the likely electrical demand requirements per lot and allow for this in the initial design.
- 9.7.2.4 The minimum electrical demand design criteria per lot and allowable after diversity maximum demand factor, shall be to the requirements of the line owner.
- 9.7.2.5 All new residential, commercial and industrial subdivisions shall be reticulated with underground cabling running along each side of the road reserve. The Council may allow variation for a single sided reticulation in exceptional circumstances (e.g. where lot frontages are greater than 30m in length).
- 9.7.2.6 Provision shall be made by land developers for the continuation of appropriate cabling along road frontages to facilitate the works of adjoining future development. This may be achieved by the installation of cable ducting systems. The Council may waive this requirement where it is demonstrated, with approval from the line owner, that adjacent sub-dividable land may be reticulated from another suitable route.
- 9.7.2.7 Consideration shall be given to the future extension or reinforcement of the works system without necessitating major road reserve disturbance to achieve such expansion or reinforcement. Where appropriate, spare ducting shall be installed along routes likely to be used for an extension, or reinforcement of the works.
- 9.7.2.8 Road crossings for power cables shall be kept to a minimum and where necessary, shall be at right angles to the carriageway and have minimum cover of 900mm. All power cables crossing the road shall be in an orange electrical duct of minimum diameter 100mm. Streetlight cables shall be inside a separate orange 50mm diameter electrical duct.

9.7.3 Location and Capacity

- 9.7.3.1 Voltage drop shall be no greater than permitted under the current Electricity (Safety) Regulations and the requirements and standards of the line owner.
- 9.7.3.2 Current ratings shall be in accordance with line owner's design and construction standards, and relevant legislation.
- 9.7.3.3 The design shall take into account the requirements of Section 9.7.2 with specific attention given to the following details relating to likely electrical loads:
- a) Lot size in relation to permissible coverage and anticipated usage of the lot (e.g. multiple dwellings, cross-lease and potential subdivision permitted within the zoning);
 - b) An appropriate after diversity maximum demand factor;
 - c) The design of the works shall give consideration to the likely electrical demand requirements per lot and allow for this in the initial design. Residential subdivisions should allow a minimum of 15kVA with diversity per lot and industrial subdivisions should allow a minimum of 40kVA without diversity per lot;
 - d) Future load growth and works expansion or reinforcement.
- 9.7.3.4 Existing overhead electrical cabling shall be dealt with in accordance with Section 9.10.

9.7.4 Records

- 9.7.4.1 The network utility operator shall keep and maintain as-built records of their works within the road reserve and on private property where the reticulation will be owned by the line owner in accordance with the [Electrical \(Safety\) Regulations 2010](#).
- 9.7.4.2 The line owner shall ensure that they receive and maintain as-built records of the works and ensure that such records are made available upon request and as required, mark out cable routes on site for the Council or contractors carrying out works.
- 9.7.4.3 Provision of as-built drawings for planned works shall be made available with five working days' notice during normal working hours and for emergency call outs with no prior notice at any time.

Good Practice

The following matters provide additional direction and guidance in the provision of electrical utilities.

- 9.7.4.4 Residential subdivisions should allow a minimum of 15kVA with diversity per lot and industrial subdivisions should allow a minimum of 40kVA without diversity per lot.
- 9.7.4.5 The typical design position for electrical cabling in road reserve is parallel with and 600mm from the boundary.

9.8 Electrical Reticulation, Easements and Subdivision

This section details standards that relate to subdivision and easements, as these matters affect and are affected by the provision of electrical reticulation.

Mandatory Matters

The Council requires the following standards to be met in the provision of electrical reticulation, easements and subdivision.

- 9.8.1.1 New lots shall be serviced with live 400/230v works to the boundary of each lot.
- 9.8.1.2 High voltage power lines (greater than 1000 volts) across or fronting new subdivisions shall be relocated clear of the subdivisions or placed underground with the agreement of the line owner. Variation may be granted by the Council where it is demonstrated to be impractical to achieve this requirement.
- 9.8.1.3 All new subdivisions reticulated with service boxes or poles shall have service ducting (50mm orange PVC electrical duct) from the pole or box to 1.0m within the property it is intended to supply. Wide sweeping bends shall be used. Service ducting shall be installed to the depths shown on SD901 and SD902. Duct ends shall be clearly marked within properties, and fixed by measurement to survey points or other permanent fixtures on as built records.

9.8.2 Broadband Speed

- 9.8.2.1 The network design will provide a minimum of 25 M bps transfer speeds with provision for this to be increased to 100 M bps without necessitating major road reserve disturbance.

9.9 Easements

- 9.9.1.1 It is the responsibility of the Developer to ensure that all easements are obtainable. The Developer shall, where necessary and at their expense, provide any easements and obtain any formal consents required for overhead lines, underground cabling and equipment to be installed or altered in, on, under or over property other than road reserve.
- 9.9.1.2 Easements in Gross with the line owner as the grantee/transferee shall be obtained and registered on all private land.
- 9.9.1.3 Easements are required in the following cases but shall not be limited to:
- Where new works (lines or cables) are located on private properties;
 - Where a pad mount substation, switching station or transformer is to be located on other than road reserve;
 - Where an overhead line located in a legal road intrudes into a privately-owned property. This applies especially to cross arms and conductors where air space is encroached;
 - Where an existing service main is physically altered, shifted or its status is changed, for example, to supply a new separately subdivided property;
 - Where a network cable is used to supply lot(s) in rights-of-way or access lots.
- 9.9.1.4 Easements required on land being developed under subdivision consent must be described under a memorandum of easements. Land outside the subdivision and affected by new or altered network system changes must also be described in a memorandum of easements. Where lot servicing is able to be satisfied using service mains in rights-of-way or access lots, easements shall be prescribed on the deposited plan.
- 9.9.1.5 Works are to be vested with the line owner prior to connection and livening, and registration of the easement. A separate agreement will be required to confirm vestment conditions and will be signed by approved signatories.
- 9.9.1.6 Overhead lines require 6.0m wide easement corridors symmetrical to the actual line route.
- 9.9.1.7 Underground cables require 3.0m wide easement corridors symmetrical to the actual cable route.

9.10 Rural Areas

- 9.10.1.1 Easements in gross are to be provided by the land owner, in favour of the line owner, for all new or altered works over private property. All proposed electricity easements over private property, whether the land is owned by the developer or not, must be listed under a memorandum of easements in gross on the subdivision plans.
- 9.10.1.2 400/230v works and service mains to individual premises shall be by underground cable unless precluded by ground profiles or other impediments in which case the Council may grant variation for overhead cables to traverse the area concerned.

- 9.10.1.3 Network connection points to individual lot boundaries shall be located to provide practical and legal access for service mains to specified or potential building sites.
- 9.10.1.4 Where the length of a service mains cable exceeds 200m from a network connection point to a specified or potential building site, the works designer shall state on the application drawing, the proposed service mains cable size and design criteria applicable to the lot.

Good Practice

The following matters provide additional direction and guidance in the provision of electrical reticulation and subdivision.

9.10.2 General

- 9.10.2.1 Rear lots down rights-of-way or through front lots may have ducts provided from the road reserve frontage to the rear lots ready for future service mains installation at the owner's cost. Exceptions are catered for where it is impractical to position a supply at a boundary.
- 9.10.2.2 Where practical, existing overhead 400/230v works or "service mains" crossing new subdivisions shall be placed underground.
- 9.10.2.3 Variation may be granted by the Council in regard to the location of high voltage power lines (greater than 1000 volts) across new subdivisions where it is demonstrated to be impractical to relocate them or put them underground.
- 9.10.2.4 The line owner will not connect new works or allow alterations to its network system which constitutes new work by definition in the Electricity Act 1997 and subsequent amendments, until an easement in gross has been acknowledged and receipted by the district land registrar on the properties affected. This requirement may be waived for subdivisions approved by the Council under the RMA or HASHA where property outside the subdivided property is unaffected and subdivision deposited plans with relevant transfers are lodged to the satisfaction of the line owner.

9.10.3 Rural locations

- 9.10.3.1 In remote rural subdivisions where the allotments have a large land area and it is demonstrated that the lots are not intended for habitable dwellings or buildings ancillary, the Council may waive the requirement for the supply of works to the boundary. A consent notice will be required noting that the site will not have an electricity supply.
- 9.10.3.2 Where works referred to in the above paragraphs is not practically accessible or economically viable, local generation e.g. hydro, solar, wind, may be considered as an alternative. It should be demonstrated that local electrical generation of 3kWhr minimum sustainable storage capacity over a 24-hour period per household is feasible for supplying lighting and small electrical appliances with alternative fuel for heating and cooking.
- 9.10.3.3 Recognising the extent of 11kV works in the rural sector, together with the difficulty and high cost of providing underground 11kV cabling, the Council may in accordance with Section 35 of the Electricity Act and at its discretion and in agreement with the line owner, allow overhead 11kV works and associated substations in the rural sector.

9.10.3.4 In rural locations, substations may be located on lot boundaries or within the subdivided lots to enable an adequate electrical supply to specified or potential building sites on the allotments.

9.10.3.5 In rural areas, subject to existing load and future development, the line owner may approve the use of an existing two phase 11kV overhead line for residential and general farming purposes where it is demonstrated that three phase power is not likely to be required for the management of the land (e.g. irrigation). The design of any two-phase 11kV line extension should be to a standard whereby a third phase can be run or livened without changes to poles, cross-arms or guys.

9.10.4 Private Access

9.10.4.1 Where service mains are used to service lots on a shared right-of-way, access lot, or across private land then an easement in favour of the line owner is not required. However, an easement between the respective parcels of land is necessary with the wording “right to convey electricity, telecommunications and computer data” entered as the purpose description.

9.11 Cabling, Ducting and Service Boxes

This section sets out standards for the design of cabling, ducting and service boxes.

Mandatory Matters

The Council requires the following standards to be met in the design of cabling, ducting and service boxes:

9.11.1 General

9.11.1.1 Access to a three-phase power supply shall be provided at the boundary of the road frontage of each lot of an industrial, commercial or residential subdivision.

9.11.1.2 Rights-of-way exceeding 60.0m to any allotment shall have an appropriate power cable installed to the main body of the rear allotments.

9.11.1.3 Fusing and “network connection points” shall be to the satisfaction of the line owner. No service duct system extending from a service box, within a right-of-way shall be longer than 60.0m. No service duct system in road reserve shall be longer than 10.0m.

9.11.1.4 Where either the service mains or the line owner’s works is installed within the sealed area of a right-of-way the cable is to be installed within a duct or a spare duct is to be laid beside the cable.

9.11.1.5 Appropriate registration of easements in gross to the line owner’s requirements shall be provided by the landowners prior to livening for all works. Where service cables cross other properties or rights-of-way, private easements between lots will be required prior to livening.

9.11.1.6 Any ducting systems installed in the road reserve area shall be considered as part of the works system for the purpose of as-built records.

- 9.11.1.7 Any excavation within the existing road reserve is subject to the Councils' approval including the National Code of Practice for Utilities Access to the Road and Rail Corridors and a Corridor Access approval issued by the Council.
- 9.11.1.8 Service boxes shall be set back 250mm from section boundaries and are to be clear of designated vehicular access and pedestrian ways by a minimum of 1.2m along the boundary and 700mm diagonally to the nearest point where the driveway tapers out to the kerb, refer to SD903.
- 9.11.1.9 The minimum spacing of any service box from any boundary line or survey peg shall be 250mm so as to enable future fencing construction.
- 9.11.1.10 Cable and duct locations in the road reserve area shall be in general accordance with SD901 being 600mm from section boundaries at a nominal laying depth of 1.0m (900mm cover) with provision for shared trenching with communication services.
- 9.11.1.11 All joints in duct pipe shall be watertight and shall use rubber ring seals, depending on the ducting supplied. The rubber "o" ring sealed pipe is the preferred type of duct and will replace solvent cement glued ducting in the long term.

9.11.2 Substations

- 9.11.2.1 Substations shall be of adequate design capability to supply the anticipated after diversity maximum demand with consideration to Section 9.7.3.
- 9.11.2.2 Ground-mounted substations will be permitted within new residential, commercial and industrial subdivisions.
- 9.11.2.3 Substations shall be located in the berm, (recessed into adjoining lot or public reserve) clear of designated vehicular access ways by a minimum of 1.0m and close to section frontages (but no closer than 300mm), secured either by easement or preferably designated as road reserve. The line owner is to determine the size of the recess.
- 9.11.2.4 Adequate public protection shall be provided at all substation sites, giving consideration to:
- Earthing (NZECP 35);
 - Physical location to minimise the risk of damage by vehicles; and
 - Security to protect against public access to electrical contents.

9.11.3 Approvals and Records

- 9.11.3.1 Prior to any works commencing on site, the following requirements shall be submitted and approved:
- 9.11.3.2 A line owner's approved electrical works design plan and the designated streetlight connection point.
- 9.11.3.3 The plan shall bear a design statement covering the following:
- Before diversity load per lot (i.e. 15 kVA per residential lot);
 - Compliance with the line owner's design and construction standards;
 - Compliance with the Land Development Manual.

- 9.11.3.4 A list of easement requirements for any works on titled land to be vested with the line owner and a list of reciprocal rights for service mains cables or ducts over shared rights-of-way or easements for service mains cables crossing titled land.
- 9.11.3.5 The Council signed approval of the design plan (for subdivision or large area works).
- 9.11.3.6 Prior to the 224-certification stage (for subdivision), the following details shall be forwarded via the Designer to the Council:
- A letter of acceptance by the line owner confirming that adequate services are provided:
 - As-built documentation has been filed for network extensions and/or service mains; and
 - The works has been lived and fulfils the line owner's design and construction standards and any other line owner requirements.
- 9.11.3.7 Regarding cable locations, the location and layout of the works shall be shown on the design plan, with all variations authorised by the network line operator's representative.
- 9.11.3.8 Where a shared services trench is used, separation between the services in subdivisions is required. These will be detailed in the laying specification. However, safe working distances are required for all services within minimum separations for power cables. Table 9-2 shows the minimum clearances between power and telecommunications cables. SD901 and SD902 show the general layout of services.

Table 9-2 Minimum Separations Between Power and Telecommunications Cables

Voltage and cable type	At Crossings		On Parallel Runs	
	With protection	Without protection	With protection	Without protection
LV, neutral screened, or armoured	50mm	150mm	50mm No limit to length	300mm No limit to length
LV, neutral unscreened, or unarmoured	50mm	450mm	450mm No limit to length	450mm No limit to length
HV, single and multicore	150mm	450mm	450mm 2.4km limit to length	450mm 2.4km limit to length

LV (low voltage) power cable is defined in the current electricity regulations as "any voltage exceeding 50 volts a.c. or 120 volts ripple free d.c. but not exceeding 1000 volts a.c. or 1500volts d.c.

HV (high voltage) power cable is defined in the current electricity regulations as "any voltage exceeding 1000 volts a.c. or 1500 volts d.c.

9.11.4 Protection

- 9.11.4.1 The depth and offset of trenches will be specified on the laying plan. It is essential that these be maintained. Minimum cover shall generally be as shown on SD901, SD902 and SD904.
- 9.11.4.2 All services crossing the proposed duct pipe route shall be exposed and the necessary clearances maintained to enable other network line operator's ducts to be installed either above or below these other services. Telecommunication ducts shall be laid above power cables, but not directly above.

- 9.11.4.3 Appropriate mechanical protection shall be provided for any underground works in accordance with the line owner's design and construction standards and appropriate legislation. Cable marker warning strip shall be placed along all cable routes at half the cable trench depth.
- 9.11.4.4 Road crossings for works cables shall be in 100mm minimum orange electrical PVC ducts to the line owner's requirement at a depth of 1.0m (900mm cover).
- 9.11.4.5 At all sites where cable is installed cable marker warning strip shall be placed along the cable route at half the cable trench depth unless the cable is mole-tunnelled or drilled and ducted.

Good Practice

The following matters provide additional direction and guidance in the design of cabling, ducting and service boxes:

- 9.11.4.6 Rights-of-way no longer than 60.0m may have individual service duct systems (orange 50mm minimum diameter PVC and wide swept bends) or appropriately sized service mains cable installed from a service box on the road frontage down the right-of-way to each rear allotment.
- 9.11.4.7 Where multiple driveways make it impractical to position a service box at a common boundary between lots or where a narrow road frontage width of a lot makes the location of a service box vulnerable to damage, it is permissible to install a service duct (orange 50mm minimum diameter PVC) in the road reserve from a service box offset no more than 10.0m from the affected lot.
- 9.11.4.8 Pole-mounted substations may be permitted in rural subdivisions.
- 9.11.4.9 Pole-mounted substations may be allowed in existing overhead works.

9.12 Streetlighting

This section contains standards for the design and installation of streetlighting.

Mandatory Matters

The Council requires the following standards to be met in the design of streetlighting:

9.12.1 General

- 9.12.1.1 The lighting design must maximise safety and efficiency while minimising the life cycle cost and impact on the environment.
- 9.12.1.2 Lighting shall be designed to match the style, height and spacing of adjoining sections of road that have the same hierarchical classification.
- 9.12.1.3 Lighting should complement the neighbourhood character and, as far as is reasonably practicable, minimise the impact on the neighbouring properties and environment with regard

to aesthetics, topography, elevations, glare and light spill. The Councils' support the dark night sky concept.

- 9.12.1.4 The design must comply with all the appropriate New Zealand Standards, in particular the requirements of AS/NZS 1158 and New Zealand Transport Agency (NZTA) M30 specifications. Anything not specified within the Land Development Manual is specified in those standards.
- 9.12.1.5 Pedestrian area (Category P) lighting must comply with AS/NZS 1158.3.1 and for pedestrian crossings AS/NZS 1158.4. Vehicle area (Category V) lighting must comply with AS/NZS 1158.1.2.
- 9.12.1.6 Category V lighting should provide a lighted environment conducive to the safe and comfortable movement of vehicular and pedestrian traffic at night.
- 9.12.1.7 Category P lighting should assist pedestrians to orientate themselves and detect potential hazards, and discourage fear of crime and crime against the person.
- 9.12.1.8 New roads and public accessways shall have lighting levels and parameters by roading hierarchy classifications (refer Section 4 Transportation). The lighting level associated with that classification is given below:
- | | |
|--|-------------------|
| a) Sub Collectors, Local Roads and Residential Lanes | Category P3 |
| b) Principal and Collector | Category V4 or P3 |
| c) Arterial | Category V3 or V2 |
| d) Public Accessways | Category P4 |
- 9.12.1.9 The streetlight design must be certified by a suitably qualified and experienced lighting professional. This shall be endorsed on the plan.
- 9.12.1.10 Rural Road Flag Lights shall be installed as per clause 3.5 of AS/NZS 1158.1.1.

9.12.2 Luminaires

- 9.12.2.1 All new streetlights shall be solid state Light Emitting Diode (LED) type luminaires. Road lighting spacing shall be designed to meet the requirements in AS/NZS 1158.
- 9.12.2.2 All luminaires must have a light distribution style with a UWLR (upward waste light ratio) of less than 1%.
- 9.12.2.3 All luminaires shall have a tilt angle of 0-2.5deg, which has been set to achieve consistency across the network and reduce unwanted light spill. This will reduce the likelihood of luminaires being installed at a negative angle. A tilt angle variation may be accepted only on approval of the Engineering Manager.
- 9.12.2.4 All new luminaires should be fitted with a 7-pin NEMA socket and a DALI compatible LED driver. This is to future-proof for possible implementation of a streetlight Central Monitoring System (CMS).
- 9.12.2.5 All lighting designs must be submitted to the Council for approval.
- 9.12.2.6 In relation to pedestrian crossings, lighting levels shall meet the requirements of AS/NZS 1158.4.

- 9.12.2.7 All luminaires, in general, should be NZTA M30 approved.
- 9.12.2.8 For non-M30 approved luminaires, verification shall be by the supplier's independent M30 test criteria. Any such luminaires will also need to meet the Engineering Manager's approval in terms of expected whole-of-life cost. Whole-of-life costs are to be measured over a 20-30 year period.

9.12.3 Columns

- 9.12.3.1 The specified intended life of new pole bases shall be 50 years unless otherwise approved by the Council.
- 9.12.3.2 Columns and outreaches shall meet the requirements of the relevant AS/NZS standards:
- AS/NZS 4065 – Concrete utility services poles;
 - AS/NZS 4677 – Steel utility services poles;
 - AS/NZS 4676 – Structural design requirements for utility services poles;
 - AS/NZS 4680 – Hot-dip galvanised (zinc) coatings on fabricated ferrous articles.
- 9.12.3.3 The outer surfaces of galvanised ground-planted columns and stub bases shall be protected to 100mm above finished surface level (ground or concrete) and to the base of the column, with a continuous self-priming, non-conductive barrier coating (epoxy-mastic or similar) at least 350 micron thick.
- 9.12.3.4 All streetlight poles shall have installed at the pole door aperture an approved Streetlighting Cut Out (SLCO) for connection of the incoming neutral screen cable(s) to the flexible cable connection to the luminaire(s). All stripping back of cables to be contained within the body of the SLCO.
- 9.12.3.5 Frangible (impact absorbing) type shall be used in high-risk crash locations, within the clear zones in areas with a speed limit of 70kph and below.
- 9.12.3.6 Slip base type shall be used in high-risk crash locations, within the clear zones in areas with a speed limit of 70kph and above.
- 9.12.3.7 Painting of lighting columns is generally not permitted, but if there is a particular reason for doing so, approval shall be obtained from the Council.
- 9.12.3.8 The painting system to be used shall be the Resene paint system Altex Devoe or a similar approved equivalent. The following methods shall apply:
- Devthan 379 (previously named E-line 939) used in all exposed marine environments
 - E-line 929 used in all other locations
 - Any new paint system will require a 10-year workmanship warranty from supplier.
- 9.12.3.9 The painting system shall be applied over galvanised poles which meet hot dip galvanised standard AS/NZS 4680. (Note: this requires galvanising both inside and outside the pole.)
- 9.12.3.10 If an adjacent property has not been developed (for example, a new subdivision) and the pole cannot be positioned in line with the common boundary, locate the pole at least 5m from the boundary to allow for a future vehicle entrance.

- 9.12.3.11 Position poles at least 1m away from a vehicle entrance or kerb cutdown. Poles to be positioned to provide clearance of at least 6m from any existing street or private tree canopy. Note: where protected trees are present, large clearances may be necessary. Trees planted as part of the subdivision landscaping are to comply with the above clearances.
- 9.12.3.12 Where installing a pole against the building line, ensure that it is installed on the legal road or on the Council land and not on private property.
- 9.12.3.13 Regarding ownership, there are two regimes of underground cables within the Council areas. These are as follows:
- a) Nelson Electrical Ltd (NEL) area – All underground cables up to the fuse located in the base of the streetlight pole and all overhead cables shall be scheduled as the property of NEL. The cable from the fuse in the base of the streetlight pole up to the streetlight shall be scheduled as the property of the Council.
 - b) Network Tasman (NWT) area – All lanterns, control circuits, underground cables (except streetlight pilot cores in underground cables), relays and associated equipment up to but not inside of NWT service boxes or padmount transformers shall be scheduled as the property of the Council.
- 9.12.3.14 All unmetered lighting load connected to the line owners “works” must have prior approval from the Line Owner. Any maintenance changes or new design details must include individual site details, lamp wattages and losses and proposed livening dates. Once connected, the livening date must be confirmed to the Line Owner within 48 hours, allowing the Line Owner 24 hours (pursuant to the Electricity Governance Rules) to enter details into the Electricity Commission’s Registry. All work involving streetlights directly connected to the line owners “works” may only be performed by persons with a Authorised Holders Certificate approved by the respective line owner.
- 9.12.3.15 Prior to the issuing of the Section 224 Resource Management Act certification for new subdivisions the developer must submit streetlighting as-built data, including GPS location of all columns. This information shall be supplied on the street light data collection form.
- 9.12.3.16 Private street lighting on private roads or rights-of-way will only be permitted if the luminaires are on a separate metered circuit and a charging agreement is set up with owners and a power supply company. (Note: private streetlighting on any private right-of-ways in the Network Tasman area are approved by Network Tasman. The Council has no involvement with private streetlighting on private property).
- 9.12.3.17 The maintenance of private lights on private property will be the landowner’s responsibility.
- 9.12.3.18 The installation of privately owned road lights (owned by a power company or other private company) are not permitted on public roads.
- 9.12.3.19 Amenity lighting that is lighting for decorative purposes that does not serve to provide lighting for pedestrians, vehicles or direction signage is not permitted on legal road.
- 9.12.3.20 Regarding reserves lighting in Nelson City, lighting standards for neighbourhood parks shall be the Salisbury Short with Cardiff Column or similar design as approved by the Council.

Good Practice

The following matters provide additional direction and guidance in the design of street lighting.

9.12.4 General

- 9.12.4.1 Where existing streetlights are already installed on part of a Local Road (including cul-de-sacs or residential lanes), then any extension of that road should preferably have matching pole types, height, spacing and luminaires to provide a consistent appearance along the road. The new design shall be submitted to the Council for approval.
- 9.12.4.2 In general, all streetlight luminaires will be pole mounted type. However, for Tasman District Council, bollards may be considered for a rural zoned subdivision and will be determined on an individual case basis with the subdivision application. Note: Maintenance lifetime costs of “conventional” luminaires are likely to be significantly less than those of “decorative” luminaires.
- 9.12.4.3 In general, all new streetlights in subdivisions should be controlled using a photocell sensor switch which is NEMA compatible type. Five-pin or seven-pin types are acceptable.
- 9.12.4.4 In infill installation, the new streetlights can be connected to streetlight control cable if it is available in the vicinity of the install.

9.12.5 Columns

- 9.12.5.1 In general, all columns should be NZTA M26 compliant.
- 9.12.5.2 Ideally, lighting poles should be positioned in line with the common boundary between properties; however, these locations do not always coincide with the spacing requirements of the lighting design.
- 9.12.5.3 If column set back complies with the requirements of AS/NZS 1158.1.1 and AS/NZS 1158.1.3 recommendations, then “solid” ground embedded columns may be used.
- 9.12.5.4 Octagonal steel columns are preferred for “conventional” style luminaires.
- 9.12.5.5 Where possible, poles should be located close to reserves and other open spaces to provide light in these areas and improve safety.
- 9.12.5.6 Consider maximising the clear zone and thus road safety when placing lighting poles, especially when they are on or near bends, intersections, threshold treatments, road humps and roundabouts.

9.12.6 Reserves and Carparks

- 9.12.6.1 Generally reserve lighting will be installed by the Council following vesting of the reserve.
- 9.12.6.2 In Nelson City, Council prefers to light only those paths, access ways and cycleways that receive high night-time use. Lighting should be provided where necessary in a manner that is consistent with the Nelson City Council *Safer by Design - Crime Prevention through Environmental Design (CPTED) Guidelines*. Consideration will be given to the brightness, placement and coverage of any lights to ensure adequate illumination where necessary and to prevent adverse effects on adjacent landowners from light spill.

- 9.12.6.3 For other locations such as major access roads and car parks within reserves, AS/NZS 1158 shall be used to determine the lighting level considering the future night-time use and anticipated risk of crime as approved by the Engineering Manager.
- 9.12.6.4 In the Tasman District, the Council supports the lighting of all reserves and all lighting designs shall be approved by the Reserves and Facilities Manager prior to their installation



Appendix A Nelson/Tasman Council Street Light Data Collection Form

Site code	Plot no	Easting	Northing	Legend
				heading
Type / Attribute		Location / Value	Notes	fill in if known
				leave blank
Date Acquired - dd/mm/yyyy				
Date Installed - dd/mm/yyyy				
Date of Last Inspection - dd/mm/yyyy				
Date of Routine Maintenance - d/mm/yyyy				
Distance from boundary - m				
Distance from edge of seal - m				
Distance from kerb - m				
Lamp Wattage				
Lamps per luminaire				
Luminaire mounting height - m				
Luminaire tilt angle - degrees				
Number		1.00		
Number of luminaires				
Outreach length				
Ballast type				
Column colour				
Column make / model				
Column mounting				
Column ownership				
Column type				
Control type				
Data Source				
Group control position				
Isolation point				
Isolation point Service box no				
Lamp type				
Light metered?				
Luminaire make / model				
Origin of power supply				
Outreach type				
Plan reference				
Confidence - Location				
Shield				

NOTES

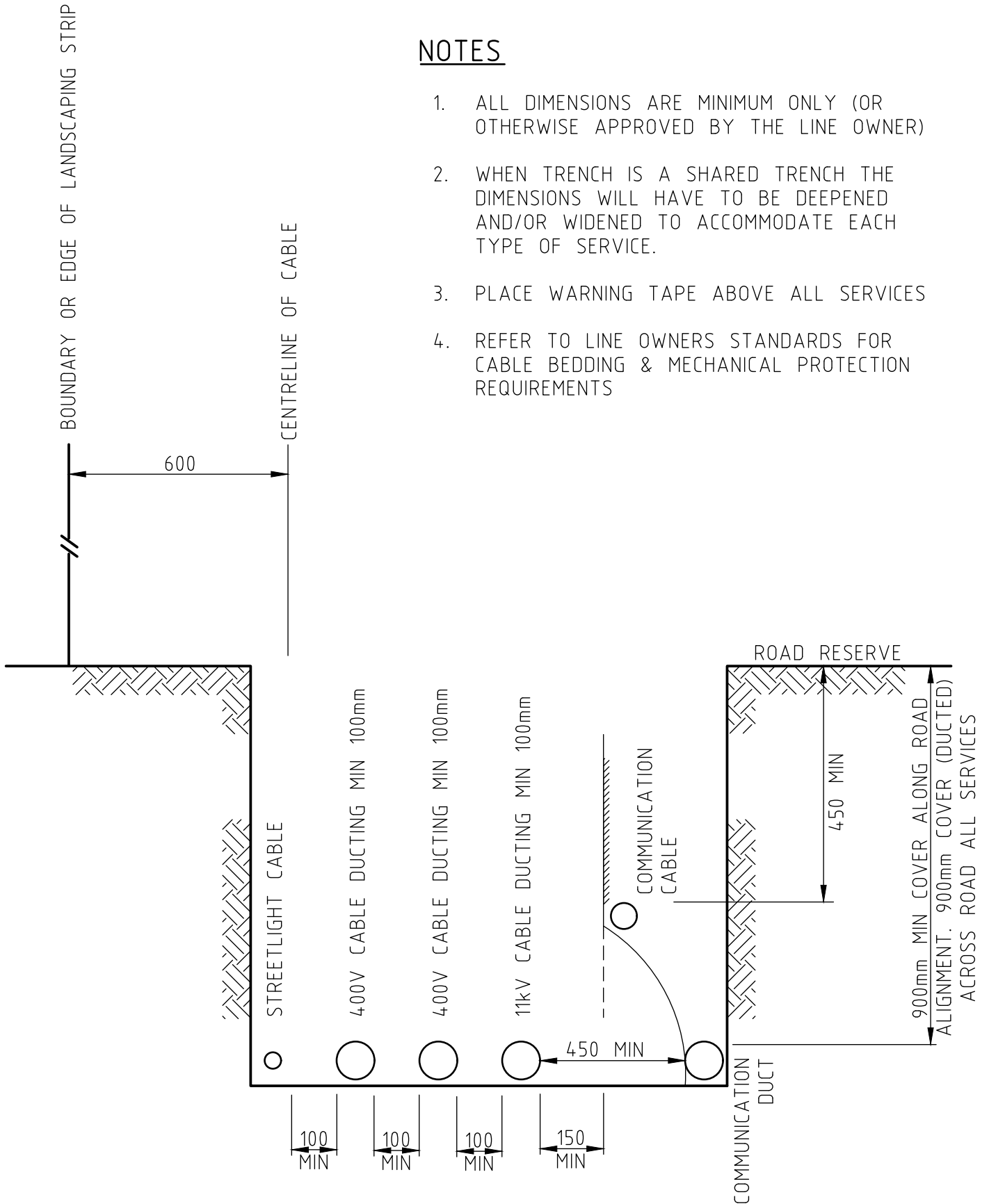
1. ALL DIMENSIONS ARE MINIMUM ONLY (OR OTHERWISE APPROVED BY THE LINE OWNER)
2. WHEN TRENCH IS A SHARED TRENCH THE DIMENSIONS WILL HAVE TO BE DEEPENED AND/OR WIDENED TO ACCOMMODATE EACH TYPE OF SERVICE.
3. PLACE WARNING TAPE ABOVE ALL SERVICES
4. REFER TO LINE OWNERS STANDARDS FOR CABLE BEDDING & MECHANICAL PROTECTION REQUIREMENTS



NELSON CITY COUNCIL  GROUP MANAGER INFRASTRUCTURE, NELSON		UTILITY RETICULATION ROAD RESERVE (DEPTH, LOCATION & CLEARANCES)	
TASMAN DISTRICT COUNCIL  ENGINEERING SERVICES MANAGER, TASMAN		DATE 01/07/19	NELSON - TASMAN LAND DEVELOPMENT MANUAL
			901

NOTES

1. * ANY CABLE WHETHER OWNED BY A LINE OPERATOR or CUSTOMER MUST BE SEGREGATED FROM A TELEPHONE CABLE BY MIN 450mm IF UNSCREENED OR 150mm IF SCREENED
2. SEE CLAUSE 9.4 RE DUCTS UNDER ROW
3. SEE TABLE 9-2 FOR SEPARATION BETWEEN POWER & COMMUNICATION SERVICES. PLACE WARNING TAPE ABOVE ALL SERVICES
4. REFER TO LINE OWNERS STANDARDS FOR CABLE BEDDING & MECHANICAL PROTECTION REQUIREMENTS

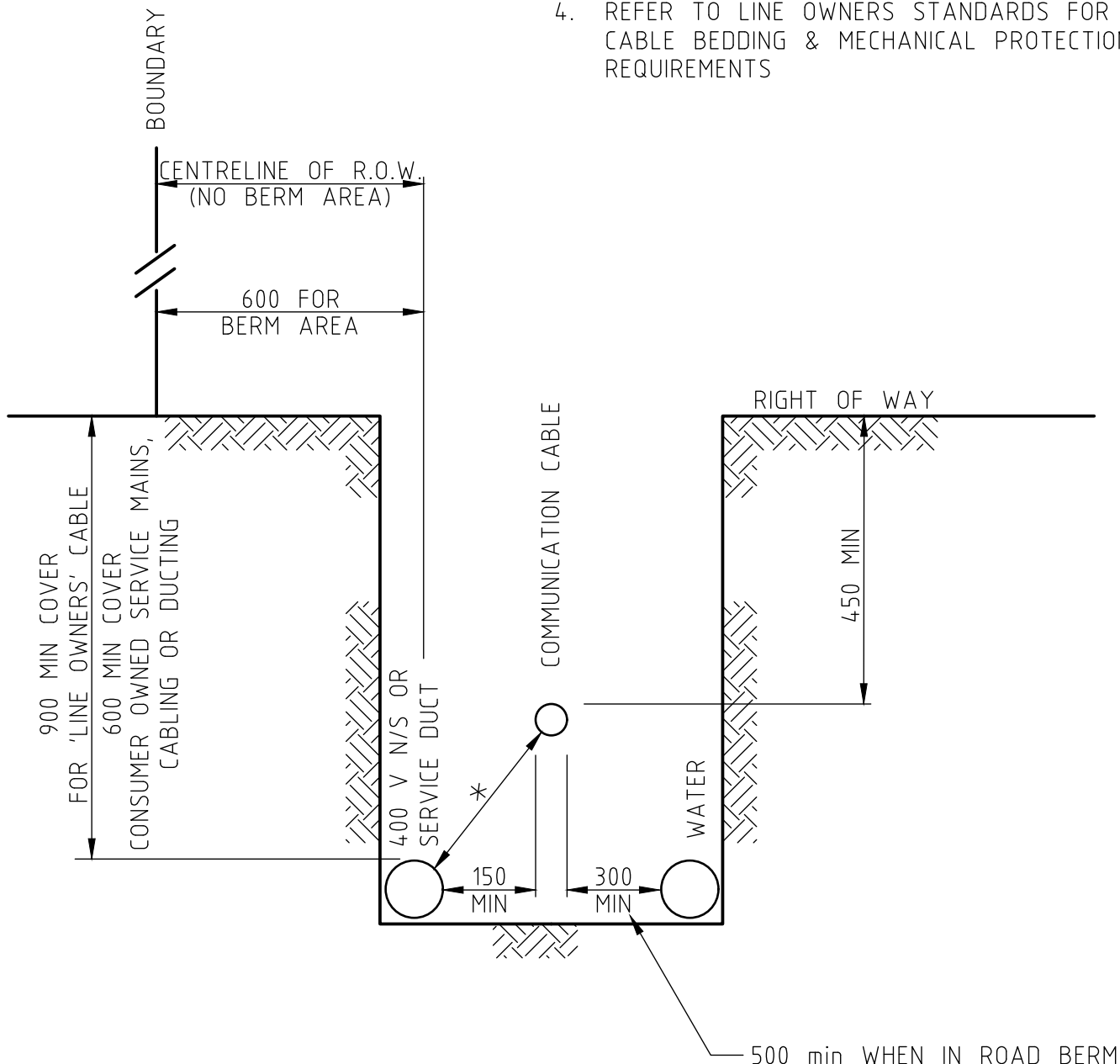

NELSON CITY COUNCIL
[Signature]
 GROUP MANAGER INFRASTRUCTURE, NELSON

**UTILITY RETICULATION ROAD RESERVE
 (DEPTH, LOCATION & CLEARANCES)**

TASMAN DISTRICT COUNCIL
[Signature]
 ENGINEERING SERVICES MANAGER, TASMAN

DATE
 01/07/19

**NELSON - TASMAN
 LAND DEVELOPMENT MANUAL**

902

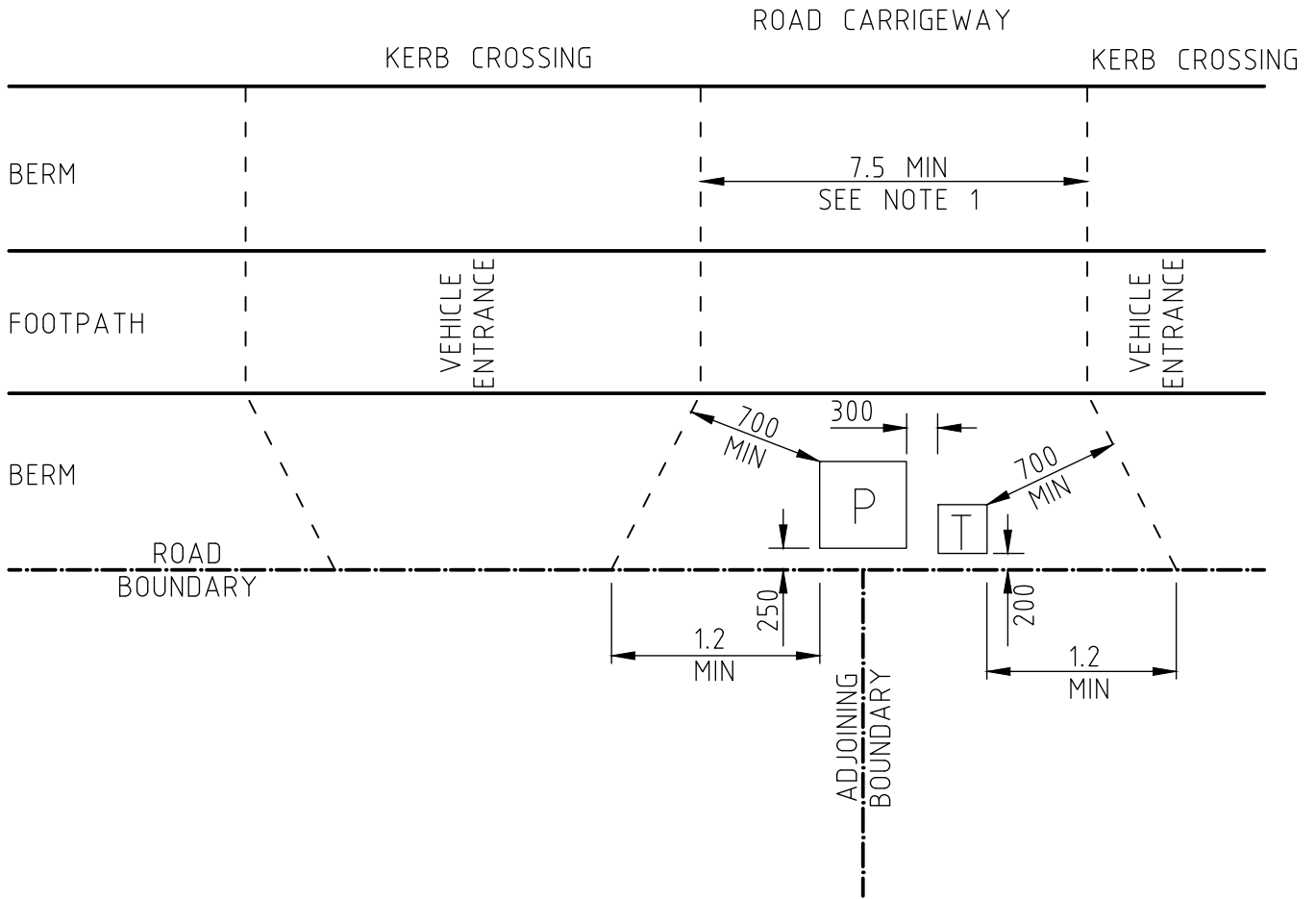

NOTES

1. VEHICLE ENTRANCES AT ADJOINING BOUNDARIES CAN BE JOINED TOGETHER AND HAVE A CONTINUOUS KERB CROSSING WHERE THERE ARE NO ABOVE GROUND UTILITY BOXES AND THE KERB CROSSING LENGTH DOES NOT EXCEED 8.0m
2. P = POWER BOX
T = TELECOMMUNICATION BOX

<p>NELSON CITY COUNCIL</p> <p><i>[Signature]</i></p> <p>GROUP MANAGER INFRASTRUCTURE, NELSON</p>		<p>ABOVE GROUND UTILITY BOX LAYOUT</p>	
<p>TASMAN DISTRICT COUNCIL</p> <p><i>[Signature]</i></p> <p>ENGINEERING SERVICES MANAGER, TASMAN</p>		<p>DATE</p> <p>01/07/19</p>	<p>NELSON - TASMAN LAND DEVELOPMENT MANUAL</p>
			<p>903</p>

PIT DIMENSIONS - OR AS APPROVED BY LINE OWNER

LENGTH 620mm
 WIDTH 300mm
 DEPTH 620mm

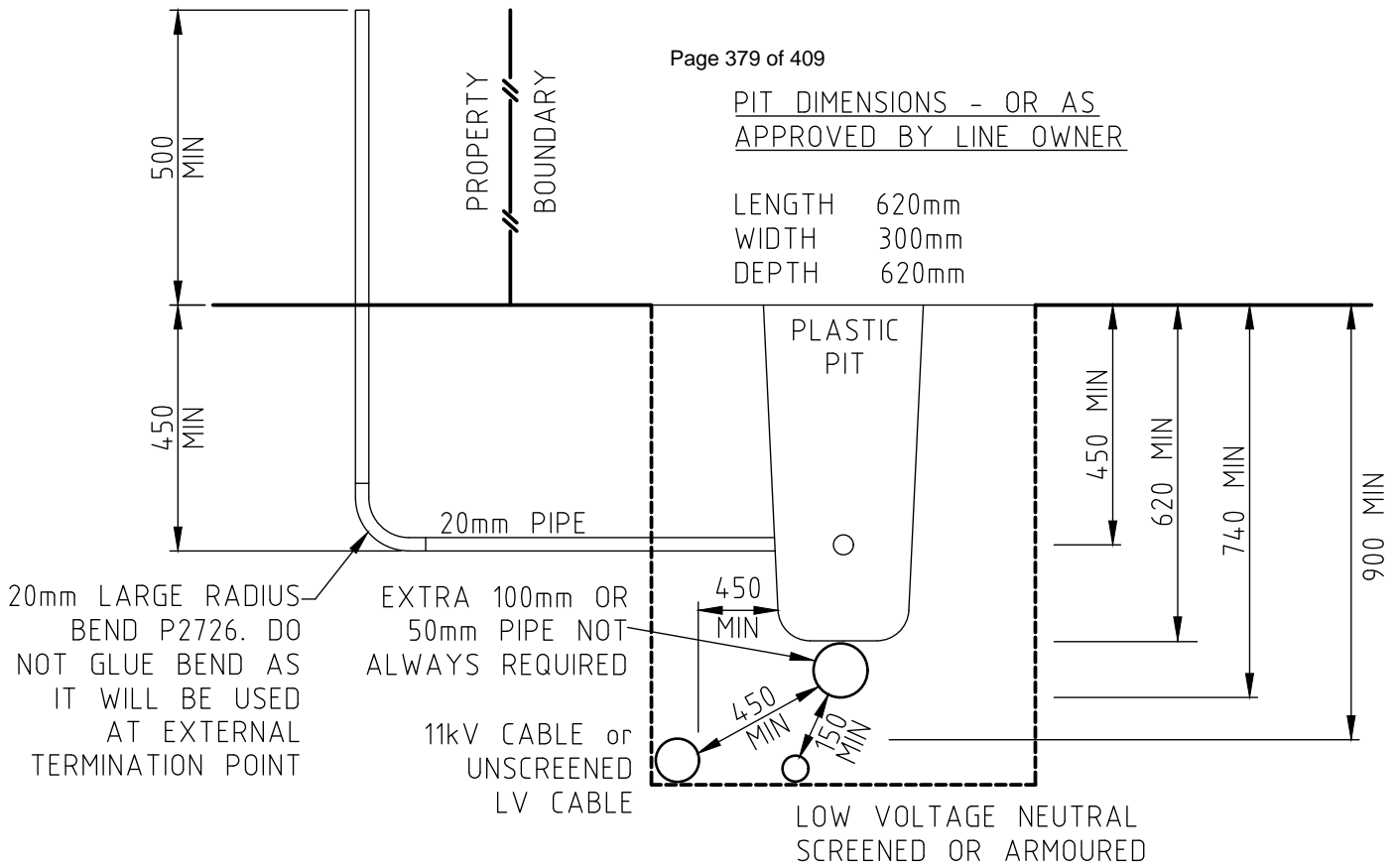

20mm LARGE RADIUS BEND P2726. DO NOT GLUE BEND AS IT WILL BE USED AT EXTERNAL TERMINATION POINT

EXTRA 100mm OR 50mm PIPE NOT ALWAYS REQUIRED

11kV CABLE or UNSCREENED LV CABLE

LOW VOLTAGE NEUTRAL SCREENED OR ARMOURD

INITIAL INSTALLATION

WHEN PULL-IN WORK UNDERTAKEN, CUT AWAY 20mm EXNT 100mm BELOW GROUND LEVEL & PLACE 400mm OF 100mm PIPE OVER BEND.

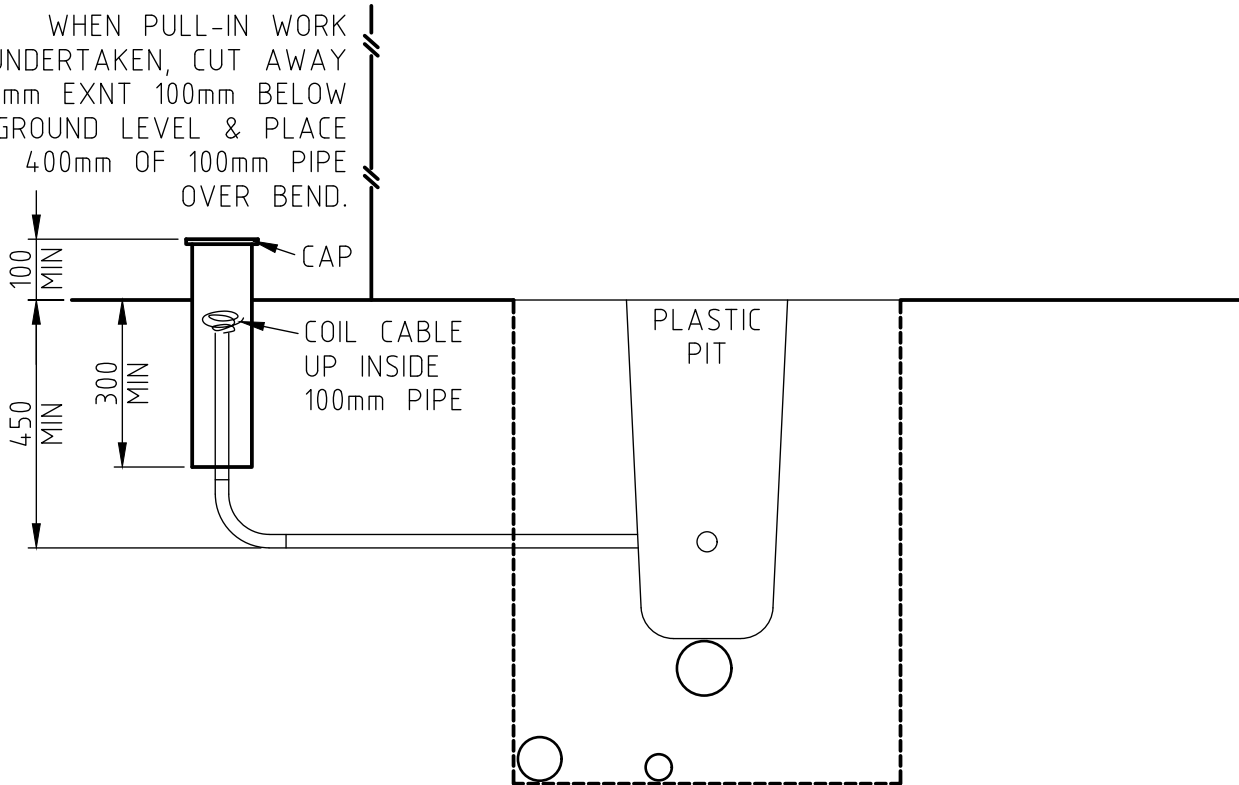

FINAL INSTALLATION WHEN CABLES PULLED THROUGH

NELSON CITY COUNCIL

GROUP MANAGER INFRASTRUCTURE, NELSON

TELECOMMUNICATION SERVICE PIT DEPTHS & CLEARANCES

TASMAN DISTRICT COUNCIL

ENGINEERING SERVICES MANAGER, TASMAN

DATE
01/07/19

NELSON - TASMAN LAND DEVELOPMENT MANUAL

904



Chapter 10

Parks and Reserves

TABLE OF CONTENTS

CHAPTER 10 PARKS AND RESERVES

INTRODUCTION	1
10 PURPOSE	1
10.1 Performance Outcomes.....	1
10.2 Referenced Documents	1
10.2.1 Reserves Act 1977.....	1
10.2.2 District Plan Requirements	2
10.2.3 External Standards	2
STANDARDS	3
10.3 Design Purpose	3
Mandatory Matters	3
10.3.1 General	4
10.3.2 Process of Determining Design Purpose.....	4
10.3.3 Neighbourhood Parks/Open Space Amenity Reserves.....	4
10.3.4 Esplanade Reserves	5
10.3.5 Conservation and Landscape Reserves/Special Interest Site Reserves	6
10.3.6 Public Gardens/Formal Gardens	6
10.3.7 Utility Reserves	6
Good Practice.....	7
10.3.8 General	7
10.3.9 Neighbourhood Parks/Open Space Amenity Reserves.....	7
10.3.10 Esplanade and Foreshore Reserves/Rural Recreation Reserves	7
10.3.11 Utility Reserves	8
10.3.12 Conservation and Landscape Reserves/Special Interest Site Reserves	8
10.3.13 Sportsgrounds.....	9
10.3.14 Public Gardens/Formal Gardens	9
10.3.15 Cemeteries	9
10.4 Access and Boundary Treatment.....	9
Mandatory Matters	9
10.4.1 Access.....	9
10.4.2 Boundary Treatment	10
Good Practice.....	10
10.4.3 Access.....	10
10.5 Other Reserve Facilities	11
Mandatory Matters	11
10.5.1 Nelson City.....	11
10.5.2 Tasman District	12
Good Practice.....	12
10.5.3 Nelson City.....	12
10.5.4 Tasman District	12
10.6 Planting	13
Mandatory Matters	13
10.6.1 General	13
10.6.2 Amenity Plantings	14

10.6.3	Riparian Plantings.....	14
10.6.4	Maintenance required during establishment.....	15
	Good Practice.....	16
10.6.5	General	16
10.7	Presentation of Reserves to Vest.....	16
	Mandatory Matters	16
10.7.1	General	16

LIST OF TABLES

Table 10-1	External Standards	2
Table 10-2	Useful references for Reserve and Associated Asset Design and Provision	2
Table 10-3	Nelson City Council Path, Track, and Road Category Standards within Reserves.....	19

LIST OF FIGURES

Figure 10-1	Indicative Utility Reserve Layout (not to scale)	8
Figure 10-2	Riparian Planting Zones (not to scale)	15

CHAPTER 10 PARKS AND RESERVES

INTRODUCTION

10 PURPOSE

The purpose of this chapter is to outline the standards for the design and creation of reserves that are to be vested in the Council. The aim is to achieve a high standard of accessibility, public health and safety, variety, multifunctional use, and environmental value, whilst maintaining whole-of-life affordability.

Reference to the Manager means the Manager Parks and Facilities (Nelson City Council) or the Reserves and Facilities Manager (Tasman District Council).

10.1 Performance Outcomes

Reserves are an important element of an urban neighbourhood or rural area. They provide opportunities for recreation and social contact, and their spaciousness contrasts with built development. The way a subdivision relates to public spaces such as roads, reserves, rivers and streams is very important for their usability, amenity and public safety.

The performance outcomes for the design and creation of reserves and associated assets sought by these standards are as follows:

- a) Sufficient provision of reserves to meet levels of service for recreation, social contact, neighbourhood amenity, access and natural values;
- b) Variety of reserves throughout the City/District, such as neighbourhood parks, esplanade reserves, walkways and playgrounds;
- c) Highly accessible reserves for a range of users, including pedestrians and, cyclists;
- d) Multifunctional reserves that can accommodate other functions or values where appropriate, such as stormwater management, natural and cultural heritage protection, and walkways and cycleways;
- e) Reserves that are affordable and accessible to operate and maintain;
- f) Reserves that are safe for all users;
- g) An interconnected network of reserves that maximises opportunities for urban greenways, walkways and cycleways;
- h) Reserves that are completed to a high standard of presentation prior to vesting in the Council; and
- i) Reserves plantings that meet amenity, natural character, beautification (including colour), ease of maintenance and efficiency values, whilst avoiding off-site effects.

10.2 Referenced Documents

10.2.1 Reserves Act 1977

The Reserves Act 1977 was established to acquire, preserve and manage areas for their conservation values or public recreational and educational values. The Reserves Act provides for the acquisition of land for reserves, and the classification and management of reserves.

10.2.2 District Plan Requirements

The Standards set out in this chapter address matters that are specific to the Council asset creation or activities that may have an impact on an asset. They are subject to the Nelson City and Tasman District Resource Management Plans. Key provisions of the Plans that preside over the design and creation of a reserve are urban design, subdivision and reserves and open space sections.

10.2.3 External Standards

Reserves will be designed and created in a manner consistent with the standards set out in this document. Additional requirements may be specified from the documents set out in Table 10-1. Where an Act or National Standards document is referenced, this will be the current version including any associated amendments.

Table 10-2 sets out additional documents that may be useful references for designers, but the use of these is not mandatory.

Table 10-1 External Standards

Number/Source	Title
New Zealand Standard: NZS 8630	New Zealand Handbook – Tracks and Outdoor Visitor Structures
New Zealand Standard: NZS 5828	New Zealand Handbook – Playground Equipment
New Zealand Standard: NZS 8409	New Zealand Standard for the Management of Agrichemicals
Ministry for the Environment	National guidelines for crime prevention through environmental design in New Zealand (CPTED)

Table 10-2 Useful references for Reserve and Associated Asset Design and Provision

Number/Source	Title
Nelson City Council	Parks and Reserves Asset Management Plan
Tasman District Council	Parks and Reserves Activity Management Plan
Department of Conservation	Outdoors Sign Manual
Tasman District Council, Tasman Resource Management Plan	Chapter 16.1 – Outdoor signs and advertising
Nelson City Council/Department of Conservation	Living Heritage - Growing Native Plants in Nelson
Tasman District Council	Native Plant Restoration Lists
Nelson City Council/Department of Conservation/Tasman District Council	Streamside Planting Guide
Nelson City Council	Street Tree Guidelines
Tasman District Council	Permitted Street Trees

STANDARDS

10.3 Design Purpose

This chapter sets out the Councils' expectations for the design of a reserve, based on its purpose, values, character and users.

Nelson City and Tasman District Councils' take, purchase and develop reserve land for the following management purposes:

Nelson City Council	Tasman District Council
Neighbourhood Parks	Urban Open Space and Amenity Reserves
Esplanade and Foreshore Reserves	Rural Recreation and Esplanade Reserves
Conservation and Landscape Reserves	Special Interest Sites
Sportsgrounds	Sportsgrounds
Public Gardens	Formal Gardens
Cemeteries	Cemeteries
Utility Reserves	Utility Reserves
Access	Walkways/Shared Paths

The purposes of Esplanade and Foreshore Reserves, Rural Recreation and Esplanade Reserves are outlined in section 229 and amendments of the Resource Management Act.

The purposes of Conservation and Landscape Reserves/Special Interest Sites are:

- To protect and restore indigenous vegetation, habitats and ecosystems;
- To protect archaeological and historic sites and values;
- To maintain and restore natural landscape characteristics, especially those that form the Nelson city and Richmond backdrop; and
- To allow and encourage public use of the reserve.

The purpose of Neighbourhood Reserves is to provide accessible informal recreation close to home, primarily for play and social interaction and enhancing the amenity of residential areas

The purpose of Sportsground Reserves/Sportsgrounds reserves under this chapter is to provide a range of sportsgrounds that are accessible and meet the changing needs of residents. Sportsground Reserves/Sportsgrounds are distributed throughout the Nelson and Tasman areas on large flat versatile sites.

The purpose of Public/Formal Gardens reserves is to provide a flagship role for the Nelson City and Tasman District's identity and heritage, by providing a number of reserves that highlight a wide range of horticulture, plant collections and landscape features and styles.

The purpose of reserves for cemeteries is to provide cemeteries in a park-like setting that meet community expectations and are consistent with the community's beliefs, feelings and range of choices.

Mandatory Matters

The Council requires the following standards to be met for the intended purpose of any reserve:

10.3.1 General

- 10.3.1.1 Gaps in neighbourhood park/reserve provision identified in the NRMP, TRMP, Parks and Reserves Asset/Activity Management Plan or an indicative reserve is identified in a structure plan or outline development plan (including the need to protect natural or archaeological features, linkages, viewpoints or rest areas) must be used to assist in determining appropriate sites for reserves.
- 10.3.1.2 Prior to lodging subdivision applications, developers must undertake pre-application consultation with the Major Projects Team and/or the Urban Design Panel in Nelson and the Manager, Lead Overseer, relevant staff and the Urban Design panel where appropriate in Tasman. The purpose of these discussions is to facilitate the integrated design of the reserve with the subdivision or adjacent areas and ensure that urban design goals are met in the design of both private and public spaces, and any areas for utility or transportation purposes.
- 10.3.1.3 The placement of utilities (including stormwater, water or sewerage pipes or power supply or telecommunication lines) which may compromise future use of the reserve must be avoided wherever possible.
- 10.3.1.4 If the placement of a utility within a reserve is unavoidable, a plan and reasons why the utility cannot be located elsewhere must be submitted to the Manager for approval prior to confirming their location.
- 10.3.1.5 No credit against reserve financial contributions will be given for land within Local Purpose (Utility) Reserves below Q15 or esplanade reserves where the adjoining allotment is under four hectares.
- 10.3.1.6 A partial credit may be given for Local Purpose (Utility) Reserves above Q15 if the reserve is requested to meet the Councils' level of service for recreation or open space and the use of the reserve for utility purposes does not compromise the recreation/open space function.

10.3.2 Process of Determining Design Purpose

- 10.3.2.1 Following pre-application consultation with the Manager, the location and size of a reserve will be included in the scheme plan submitted with the subdivision application. The vesting of the reserve, its classification and any development requested by or agreed to be the Manager will be a condition of the consent.
- 10.3.2.2 There is no requirement for a concept plan for the development of a reserve to be provided. The reserve is required to be presented for vesting in accordance with these standards. Development of the reserve will generally be undertaken following vesting and in consultation with the community.

10.3.3 Neighbourhood Parks/Open Space Amenity Reserves

- 10.3.3.1 Must be located and designed so that they are connected with the existing roading network and where possible, existing reserves, access ways and open spaces to provide routes and return loops for recreational use, encourage sustainable transport choices by allowing for continuous off-road journeys and contribute to creating larger open space areas. Consideration should be given to how the development will link to the surrounding landscape, including existing areas of open space, and to other public areas, such as schools, town centres, community facilities or public transport
- 10.3.3.2 Must not be made of "left over" land, the location and design must be informed by the neighbourhood context and the particular aspects of the site.

- 10.3.3.3 Must be designed and presented in accordance with these standards prior to the application for section 224(c) certificate approval.
- 10.3.3.4 Must at a minimum aim to have a total area of 2,500 m² and a useable, flat area of 1,250 m².
- 10.3.3.5 Land will only be vested as recreation reserve if it meets the neighbourhood reserve criteria.
- 10.3.3.6 The level of service for the location of Neighbourhood Parks in relation to residential properties in Nelson City is determined in the Nelson City Council Parks and Reserves AMP.
- 10.3.3.7 The level of service for the location of Urban Open Space Amenity Reserves in relation to residential and rural properties in Tasman District is determined in the Tasman District Council Reserves and Facilities AMP.
- 10.3.3.8 Must be of an even and regular shape that allows for maximum usable space and ease of maintenance.
- 10.3.3.9 Must be highly visible in order to maximise amenity, safety and open space benefits for the surrounding community and to allow the reserves to be easily found by users, and meet the following standards:
- a) Have a minimum 30 metre road frontage on at least one side;
 - b) Be located on a through road, or connect two cu-de-sacs;
 - c) Have additional access points provided to connect to the road network within the subdivision and adjoining areas;
 - d) Have access crossings provided for maintenance vehicles and equipment;
 - e) Be located and orientated to maximise daylight and sunlight hours;
 - f) Developed so as to reduce drafts, shading and cold;
 - g) Encourage neighbouring properties to have living spaces facing onto the reserve; and
 - h) Located to ensure that potential hazards to public safety (such as site stability or contamination) do not exist or it is possible to remedy or mitigate any hazard.
- 10.3.3.10 Natural features or features of local and/or cultural interest or significance such as streams, remnant native forest or specimen trees will be identified and included within the reserve where appropriate and agreed to by the Manager.
- 10.3.3.11 Must not be used as a storage area or access to residential building sites by contractors.

10.3.4 Esplanade Reserves

- 10.3.4.1 The circumstances, where reserves under this chapter must be provided or considered adjoining lakes, rivers or the coast, are prescribed within the Nelson and Tasman Resource Management Plans. The Council may seek to purchase additional areas to add to the environmental, amenity and recreational value of the reserve network.
- 10.3.4.2 Paths on esplanade reserves must be provided where they are an integral part of a walking/cycling connection within the subdivision or wider area.
- 10.3.4.3 Given the generally long and linear nature of these reserves, visibility and accessibility must be maximised to enhance the amenity, safety and open space benefits for the surrounding community and to allow them to be easily located.

10.3.4.4 Coastal margins and river/stream banks will be presented in a stable and natural state. See section 10.6.3 for planting requirements for riparian areas.

10.3.5 Conservation and Landscape Reserves/Special Interest Site Reserves

10.3.5.1 Where possible conservation and landscape reserves/special interest site reserves must have a minimum of 20 metres road frontage, with good access for pedestrians and maintenance vehicles.

10.3.6 Public Gardens/Formal Gardens

10.3.6.1 Public gardens and formal gardens must have a minimum 30 metre road frontage, with good pedestrian and maintenance vehicle access.

10.3.7 Utility Reserves

10.3.7.1 Where reserve land is to be vested for stormwater management purposes (including the associated maintenance access corridor) it must be vested as a Local Purpose Reserve at no cost to the Council, integrated into the design of the development and enhanced with planting to provide for environmental and amenity values.

10.3.7.2 Utility reserves adjoining waterways must incorporate any adjacent the Council-owned stormwater detention or treatment infrastructure (such as detention ponds or constructed wetlands) and all riparian habitats (including river banks, upper terraces and adjacent annual flood plains and natural wetlands) plus adjacent areas of riparian vegetation. This will allow for integrated management of the waterway environment.

10.3.7.3 The location and design of utility reserves must be subject to the approval of the Manager prior to lodging an application for a subdivision consent.

10.3.7.4 Reserves and open space areas that also have stormwater management functions will be designed in accordance with the Stormwater Chapter of the Nelson Tasman Land Development Manual (NTLDM).

10.3.7.5 Must not have flooding or ponded stormwater for storm events up to and including a 15-year design storm (Q15 or 6.6% AEP) in Nelson and Richmond and a 10-year design storm (Q10 or 15% AEP) for the remainder of the Tasman District.

10.3.7.6 Must have a soil type/s, detention structure(s) and a water table so that flooding is no deeper than 200mm and any storm water drains away within 24 hours.

10.3.7.7 Any stormwater detention or treatment devices including stormwater reticulation must be designed and constructed in accordance with the requirements of the Stormwater Chapter of the NTLDM.

Good Practice

The following matters provide additional direction and guidance to be considered for land to be vested as a reserve:

10.3.8 General

10.3.8.1 A partial credit may be given for Local Purpose (Utility) Reserves above Q15 if the reserve is requested to meet the Councils' level of service for recreation or open space and the use of the reserve for utility purposes does not compromise the recreation/open space function.

10.3.9 Neighbourhood Parks/Open Space Amenity Reserves

10.3.9.1 These reserves may be developed with amenity plantings, paths, park furniture and playgrounds subject to the approval of the Manager.

10.3.9.2 General design principles should include:

- a) Wide, open road frontage to enhance visibility and safety;
- b) Sufficient space so that amenity plantings can be undertaken around the perimeter and within the reserve in a manner that does not obstruct sightlines, public safety and visibility through the park/reserve;
- c) Plantings of larger tree species for amenity and shade in the summer. If larger amenity trees are proposed, consideration and approval must be given to the species proposed, location and effects on neighbouring properties;
- d) Any play equipment and/or seating will generally be located to capture the highest sunlight and daylight hours in winter;
- e) Play areas may include landscape elements as well as formal play equipment such as swings and slides; and
- f) Low and/or natural barriers and fencing with neighbouring properties are encouraged to enhance safety through passive surveillance.

10.3.9.3 Where the Council is already meeting its levels of service for neighbourhood reserves, an area of land may be considered for vesting as reserve if the land is taken to protect trees, buildings, sightlines, views, landscape character, protect biodiversity, enhance local amenity or provide visually appealing areas for passive recreation.

10.3.10 Esplanade and Foreshore Reserves/Rural Recreation Reserves

10.3.10.1 Consideration should be given to how these reserves will link to the surrounding landscape including:

- a) Existing esplanade reserves or strips or other reserves;
- b) The road network; and
- c) Other public areas.

10.3.10.2 An access point should be provided approximately every 250-300 metres in urban environments and on a case by case basis and as agreed to by the Manager in rural environments.

10.3.10.3 Surveillance from neighbouring properties should be encouraged.

10.3.11 Utility Reserves

- 10.3.11.1 There are no specific minimum or maximum widths for utility reserves, the width is dependent upon allowance for the design flood flow and an area adjoining one or both sides of the design floodway to accommodate maintenance vehicle access, pedestrian/cycle and amenity plantings (refer to Figure 10-1 and the Streamside Planting Guide for information).
- 10.3.11.2 Ground slopes should generally not exceed 1V:5H to enable maintenance of any grass and safe ingress and egress for the public.
- 10.3.11.3 Consideration should also be given to connections between utility reserves and any other local reserves and the wider transport network.

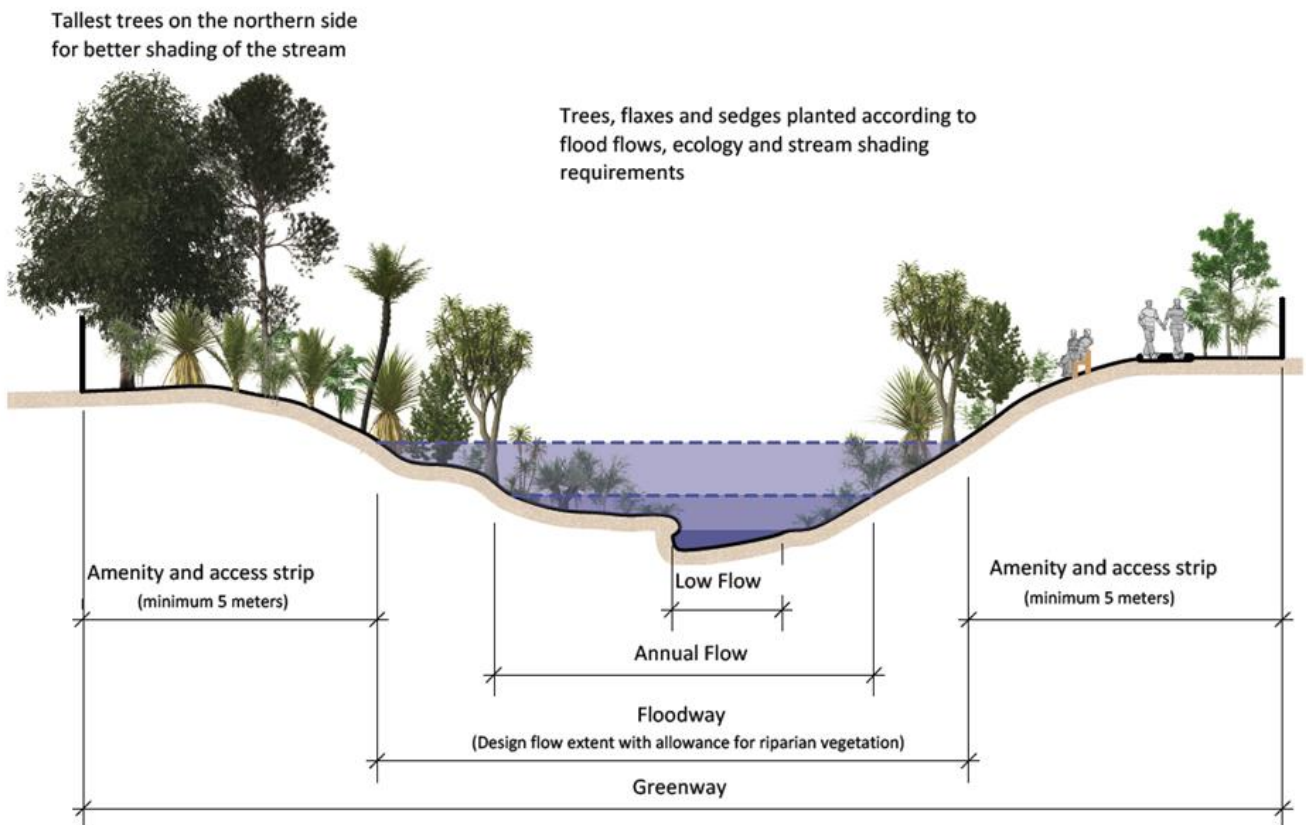

Figure 10-1 Indicative Utility Reserve Layout (not to scale)

10.3.12 Conservation and Landscape Reserves/Special Interest Site Reserves

- 10.3.12.1 The Council may seek further land where there are accessible areas of high or potentially high natural or heritage values that require protection and management, or where the land may enhance an existing Conservation and Landscape Reserve or Special Interest Reserve by providing connectivity or a buffer area.

10.3.13 Sportsgrounds

10.3.13.1 The Council may seek further land as required for this purpose. Future provision needs for sportsgrounds are identified in the Nelson City and Tasman District Council Parks and Reserves Asset/Activity Management Plans and indicative reserve notations in the relevant Resource Management Plan.

10.3.14 Public Gardens/Formal Gardens

10.3.14.1 The Council may seek to negotiate or purchase further land if an accessible property containing significant gardens, landscaping or treescapes worthy of protection becomes available for sale.

10.3.15 Cemeteries

10.3.15.1 The Council may seek to purchase additional land for the purpose of Cemeteries, particularly land adjacent to existing cemeteries to meet identified levels of service.

10.4 Access and Boundary Treatment

This section outlines the standards and design for access to and within reserves and boundary treatments.

Mandatory Matters

The following standards are required in the design of access to and within reserves:

10.4.1 Access

- 10.4.1.1 In Nelson City, the design and standards of formation for paths and tracks within reserves are outlined in Table 10-3. The minimum legal width of any pedestrian and cycleway access must be six metres including berms and landscaping. Where access ways to reserves and paths within reserves form an integral part of the wider walking/cycling network, then the connection within the subdivision will be formed by the consent holder prior to vesting of the reserve.
- 10.4.1.2 In Tasman District, the standards of formation for paths and tracks must comply with SNZ 8630 where practicable, except paths in reserves in urban zones and on access ways to reserves will have a minimum width of 1.4 – 2 metres for pedestrian paths and a minimum width of 2.5 – 3 metres for shared pathways.
- 10.4.1.3 A clear space buffer on either side of paths of at least one metre between the height of 1.2 metres and 2.4 metres must be provided to ensure adequate visibility for cyclists.
- 10.4.1.4 The location of paths and plantings on reserve access ways and walkways must be designed to ensure the path receives maximum sunlight hours in winter and minimises frosting.
- 10.4.1.5 A vehicle access crossing must be installed by the Developer prior to vesting of the reserve in accordance with Chapter 4 - Transportation. A vehicle crossing access permit is required or the crossing needs to be approved through the submission of Engineering Plans as part of the subdivision process.
- 10.4.1.6 Consultation with the Council must be undertaken to determine if parking areas and access roadways are required.

10.4.2 Boundary Treatment

- 10.4.2.1 All boundary fencing must comply with the provisions of the relevant Resource Management Plan.
- 10.4.2.2 Where a Local Purpose (Utility) Reserves is vesting as part of a development, the developer must fence all private boundaries of the reserve at their cost prior to section 224(c) certificate approval. The maximum height of the fence will be 1.2 metres and the fence will be visually permeable.
- 10.4.2.3 In rural areas, if boundary fencing is required it must be installed by the developer prior to the application for section 224(c) certificate approval.
- 10.4.2.4 In all areas the developer must consult the Manager to determine the appropriate fencing for the location should fencing be required.
- 10.4.2.5 Where board or paling fences are used, all structural railings will be located on the residential property side of the fence and the timber on the reserve side of the fence must be left natural with a natural finish (not painted or stained).
- 10.4.2.6 If required by the Council, vehicle barriers and or bollards must be installed by the developer prior to vesting of the reserve. Their design and the materials used in their construction will be approved by the Manager.

Good Practice

The following matters provide additional direction and guidance for access to and within reserves and boundary treatment:

10.4.3 Access

- 10.4.3.1 The design of an access should be determined by its form and function. For example cycle paths are required to be 3 metres in width, pedestrian access 2 metres in width – refer to Table 10-3 for detailed design information.
- 10.4.3.2 In the Tasman District access ways and paths within reserves will usually be formed by the Council following vesting, unless they form a link within an existing network or agreed otherwise with the developer.
- 10.4.3.3 In Nelson City, it is preferred that walking and shared pathways through reserves are constructed in concrete where possible, to avoid weed incursions that typically create maintenance issues with asphalt, particularly cynodon dactylon (dhoob) and cenchrus clandestinus (kikuyu).
- 10.4.3.4 Linkages to reserves for pedestrians and cyclists should create an attractive, friendly, connected, safe and accessible environment.
- 10.4.3.5 Steps on paths in urban areas should be avoided to allow for cycle and mobility vehicle use. Where steps are required, a half-round open concrete channel should be formed adjacent to the steps to assist cycle movement.
- 10.4.3.6 Open frontages onto reserves and reserve access ways and walkways are promoted. A sense of openness between residential properties and reserves or access ways or walkways is required

to maintain streetscape amenity, encourage a sense of community, provide opportunities for passive surveillance and improve safety in public spaces

- 10.4.3.7 Hedges, climbers on trellis or other green living barriers are preferred in the Nelson urban environment, and only up to a maximum height of 1.2 metres.
- 10.4.3.8 Solid barriers between reserves and roads are generally not encouraged in the Nelson urban environment. Where possible planting and landscaping should be used as the means of deterring unauthorised vehicles. Barriers may be required in Tasman, particularly for less urban situations in order to deter unauthorised vehicle use.
- 10.4.3.9 Where vehicle barriers are required to control unauthorised vehicles, this may be in the form of a standard non-mountable kerb, or a physical vehicle barrier or bollards. Vehicle barriers should meet the following objectives:
- a) Prevent vehicles from accessing reserve land;
 - b) Continue to allow pedestrian and cycle access;
 - c) Be of a design that ensures consistency with other reserve structures and furniture;
 - d) Does not adversely affect the visual amenity of the area;
 - e) Does not greatly increase maintenance requirements; and
 - f) Able to withstand or discourage vandalism.
- 10.4.3.10 Bollards should be placed to allow for easy mowing and maintenance and either be on a mowing square (350 x 350mm) or incorporate a mowing strip and bollards should be spaced either two or three metres apart with a connecting chain.

10.5 Other Reserve Facilities

This section outlines the standards and design for reserves facilities such as lighting, signage and furniture.

Mandatory Matters

The Council requires the following standards to be met in the design and location of other reserve facilities:

10.5.1 Nelson City

- 10.5.1.1 If lighting is required for neighbourhood parks, the design shall be consistent with AS/NZS1158 and must be approved by the Manager prior to construction.
- 10.5.1.2 Where reserve signage is required, it will be installed by the Council following vesting of the reserve in accordance with the requirements of the Nelson City Council Outdoor Sign Manual.
- 10.5.1.3 Reserve furniture must be set back a minimum of one metre from any path or cycleway, and will not obstruct any pedestrian throughway of public spaces.
- 10.5.1.4 If bench seating is required, the Manager will advise on the seat design best suited to the environment and use for which it is intended.

- 10.5.1.5 Any equipment and surfacing installed must comply with NZS 5828, Playground Equipment and Surfacing. In addition, all equipment and surfacing must meet the requirements of required building or resource consents.

10.5.2 Tasman District

- 10.5.2.1 If lighting is required for reserves, the design shall be consistent with AS/NZS1158 and must be approved by the Manager prior to construction.
- 10.5.2.2 Where reserve signage is required, signs will be installed in accordance with the Tasman District Council Reserves General Policies document and Chapter 16.1 of the TRMP. Signs associated with tracks and buildings will adopt the recommendations of the Standards NZ Handbook for Track Tracks and Outdoor Visitor Structures (SNZ HB 8630). New signs on reserves will include nationally recognised recreational symbols.
- 10.5.2.3 The design of any furniture provided by the developer must comply with NZS 5828:2015 and any consent requirement and will be approved by the Manager prior to construction.

Good Practice

The following matters provide additional direction and guidance for the design and location of other reserve facilities:

10.5.3 Nelson City

- 10.5.3.1 The Council's objective for reserve furniture is to provide interesting playgrounds that meet the needs of the local community. It is important that any proposal for the provision of reserve furniture integrates the play equipment into the landscape design for the reserve. The use of natural features in conjunction with formal play equipment is desirable.
- 10.5.3.2 It is desirable that in areas likely to be used by elderly, infirm and disabled people, bench seats are designed so that they have:
- Legs securely fixed to a concrete and/or paved slab that exceeds the foot print of the seat by 300mm all round;
 - A comfortable back that is angled no more than 10 degrees from the vertical;
 - No gap between the seat base and seat back that is wider than 110mm; and
 - Front edge of seat to be no more than 450mm above slab (ground level) and no less than 420mm.

10.5.4 Tasman District

- 10.5.4.1 The Council may light paths, access ways and cycleways that receive high night-time use. Lighting will be provided in a manner that is consistent with the Crime Prevention Through Environmental Design (CPTED) Guidelines. Consideration will be given to the brightness, placement and coverage of any lights to ensure adequate illumination where necessary and to prevent adverse effects on adjacent landowners from light spill.
- 10.5.4.2 Reserve furniture such as seating and picnic tables, rubbish bins, drinking fountains and other structures such as barbeques and boardwalks will generally be installed by the Council following vesting of the reserve. Approval from the Manager is required if the developer wishes to install furniture prior to vesting. Play equipment may be installed by the Council following vesting of the reserve in consultation with or at the request of the community.

10.6 Planting

This section applies to the provision of planting to enhance the environment in any part of a subdivision or where required as a condition of subdivision consent.

Mandatory Matters

The Council requires the following standards to be met in the design and preparation for planting within Reserves:

10.6.1 General

- 10.6.1.1 Where site-specific planting plans have been required, they will be submitted to the Manager for approval prior to section 223 survey plan approval.
- 10.6.1.2 Only drawings stamped and signed by the Manager or delegated officer, will be deemed to be approved drawings.
- 10.6.1.3 Plans will ensure that the plantings proposed require minimum long-term maintenance and achieve the objectives for different planting types outlined in Figure 10-2 and must include the following:
 - a) Details of timing and reasons for notifying the Council of works;
 - b) Details of proposed maintenance bonds and proof that a bond has been lodged if it is required;
 - c) Plant species, spacing and location;
 - d) Timing of planting;
 - e) Weed control methodology;
 - f) Planting and maintenance methodology and plant replacement after planting and during establishment and for a minimum of two years following planting; and
 - g) Protection of plants against pests.
- 10.6.1.4 Planting must be undertaken prior to section 224 (c) certificate approval and at no cost to the Council. Notice will be provided the Manager at least two months prior to seeking 224 (c) certificate approval so that inspections of the plantings can occur and any remedial action can be undertaken by the developer prior to approval.
- 10.6.1.5 All native plantings will be selected, planted and maintained in accordance with “living Heritage – Growing Native Plants in Nelson” and the “Streamside Planting Guide” in Nelson and with the “Native Plant Restoration” Lists and the “Streamside Planting Guide” in Tasman.
- 10.6.1.6 Plants listed in any Plan or Guidance Document prepared in accordance with the Biosecurity Act 1993 will not be used in any planting.
- 10.6.1.7 All plants will be sound, healthy, vigorous and free of any defects and pests which may be detrimental to plant growth and development. In addition, plants should have vigorous root and branch systems and plants supplied in pots must not be root bound.
- 10.6.1.8 Planting will maintain adequate visibility to ensure safety within the reserve in particular where access ways and shared paths are adjacent to dense plantings.
- 10.6.1.9 Planting adjacent to pathways and access ways will ensure that the path/access receives maximum sunlight hours in winter and that planting minimises the ability to create frosting.

10.6.1.10 Plants with strap-type leaves and plants likely to spread will be set back a minimum of 1.5 metres from the edges of paths.

10.6.1.11 Where soil is imported onto the site it will be free of noxious/environmental weeds and pests and contamination.

10.6.2 Amenity Plantings

10.6.2.1 Amenity plantings within neighbourhood parks/reserves and access ways will be provided in a manner that creates pleasant spaces for active and passive recreation while maintaining enough open space to maintain a safe environment.

10.6.2.2 Plantings will be designed to meet the following functional outcomes:

- a) Define space and create a vegetation barrier;
- b) Provide shade and shelter;
- c) Provide edible plants where appropriate;
- d) Screen unsightly outlooks;
- e) Control erosion;
- f) Enhancement of recreation and amenity value;
- g) Provide habitat and encourage bird life;
- h) Help restore native biodiversity (Refer 10.6.1.6 above); and
- i) Enhance cultural significance.

10.6.2.3 Plantings will be designed to meet the following aesthetic outcomes:

- a) Frame views;
- b) Emphasise landscape features;
- c) Soften hard surfaces; and
- d) Provide colour, form and texture.

10.6.2.4 Plantings will be designed to meet the following safety outcomes:

- a) Maintain adequate visibility for road and path users;
- b) Maintain adequate sight lines for people within the park/reserve;
- c) Adequate separation from parking areas; and
- d) Avoid obstructions to pedestrians and cyclists.

10.6.3 Riparian Plantings

10.6.3.1 Riparian plantings must be designed and provided in a manner that provides diverse riparian habitat, shades watercourses, enhances the natural environment, while maintaining enough open space to maintain a safe environment.

10.6.3.2 Species will be selected and located in accordance with section 10.6.1.5.

10.6.3.3 Plants will be eco-sourced.

- 10.6.3.4 Spacing in the lower and upper stream banks shown in Figure 10-2 will depend on the species selection but generally one plant per 1.5m².

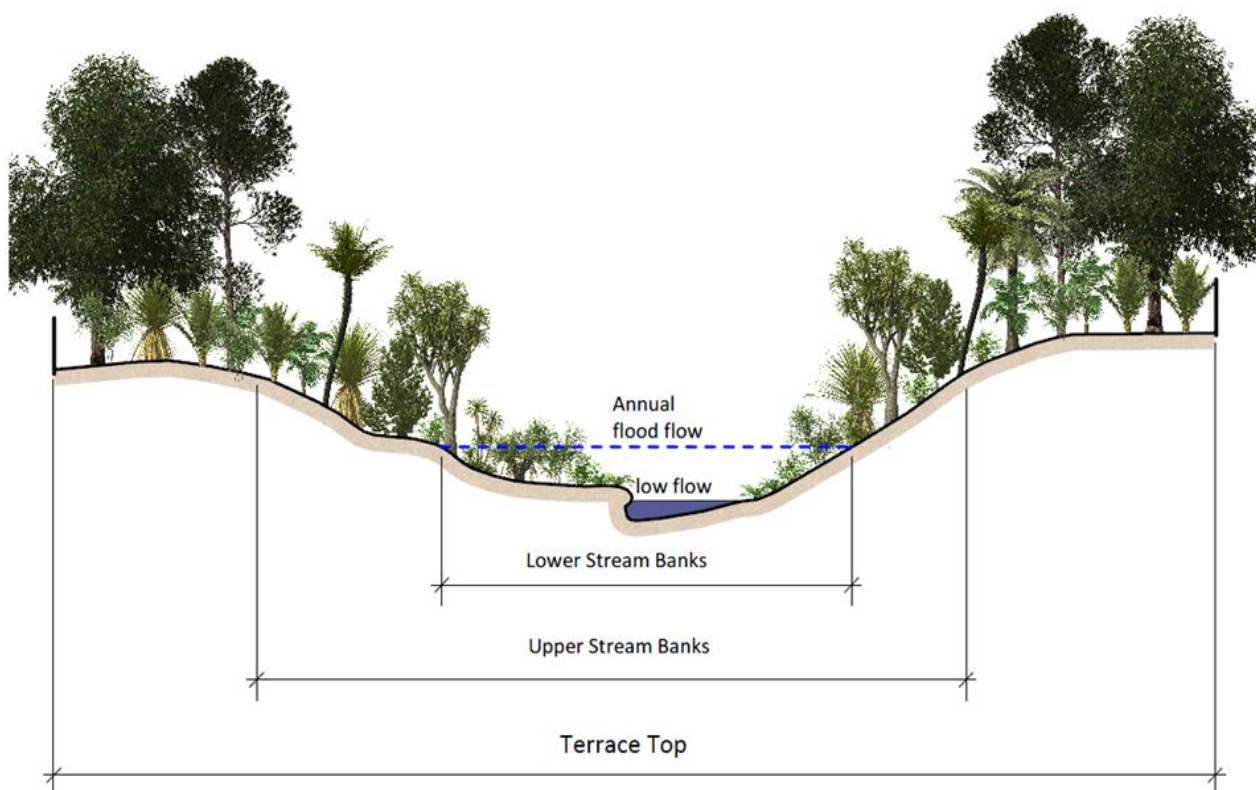

Figure 10-2 Riparian Planting Zones (not to scale)

- 10.6.3.5 Riparian planting will be designed to meet the following outcomes:

- a) Stabilise banks;
- b) Slow run-off;
- c) Shade river water (60-70% shading from a fish-eye view);
- d) Provide habitat and encourage bird life;
- e) Enhance recreation and amenity value; and,
- f) Restore native biodiversity to stream environments.

10.6.4 Maintenance required during establishment

- 10.6.4.1 For the duration of the two-year establishment period all defects (including watering, mulching, weed control, pest and disease control, staking, mowing and replacement of dead or dying plants) will be undertaken by the developer at the developer's cost and to the satisfaction of the Manager.
- 10.6.4.2 All chemical use must be undertaken in accordance with the New Zealand Standard for the Management of Agrichemicals, NZS 8409:2004.
- 10.6.4.3 Where required, wooden stakes will be used and the stakes and ties will be maintained and replaced as required, in order to fulfil their intended purpose without causing damage to the plants.

- 10.6.4.4 Where mulch or bark is used (i.e. street gardens) it must be kept at settled thickness as specified in the planting plan and will be kept away from hard surfaces. Floatable mulch will not be acceptable in stormwater flow paths.

Good Practice

The following matters can provide additional guidance in the selection and design of plantings within reserves:

10.6.5 General

- 10.6.5.1 “Crime Prevention Through Environmental Design” guidelines should be considered when designing plantings and for the two-year maintenance period.
- 10.6.5.2 Where appropriate to the site and location conditions, native planting should be prioritised over exotic and introduced species.
- 10.6.5.3 The following matters should be considered when selecting species:
- a) Overall composition;
 - b) Suitability to environmental conditions such as ground moisture, wind, likely flood flows, soil condition;
 - c) Height and spread when mature;
 - d) Pest and disease resistance;
 - e) Where exotic species are used, they should be species that have a non-suckering habit and not have a propensity to become a weed or spread seeds;
 - f) Longevity;
 - g) Existing shade environment;
 - h) The plants ability to shade waterways;
 - i) The plants ability to provide bank stabilisation or erosion control if required; and
 - j) Minimum maintenance requirements.

10.7 Presentation of Reserves to Vest

Introduction

This section sets out the minimum standards to be met prior to land being accepted for vesting as a reserve with the Council.

Mandatory Matters

The following matters are requirements for the presentation for reserves to vest:

10.7.1 General

- 10.7.1.1 No substantial land re-contouring will be undertaken at any time on the proposed reserve land after the resource consent is granted and prior to section 224(c) certificate approval without the consent of the Manager.

- 10.7.1.2 Prior to the application for section 224(c) certificate approval, land that is to be vested in the Council must be formed and presented in a manner which achieves the standards set out in this section at no cost to the Council.
- 10.7.1.3 All boundaries must be surveyed and clearly pegged (survey pegs are kept clean, clear of vegetation and able to be easily identified subsequent to vesting).
- 10.7.1.4 The land must be free of:
- a) pre-existing building remains except those identified as having heritage values;
 - b) unwanted fences;
 - c) farm utilities;
 - d) above ground tree stumps, unless identified as important for wildlife values (Trees can provide important habitat for native insects, lizards and birds);
 - e) surface rocks - unless rock formations provide a feature or important habitat;
 - f) any debris or rubbish associated with the development of the subdivision;
 - g) all pest plants and other specified unwanted vegetation; and
 - h) underground redundant structures and contaminated soils.
- 10.7.1.5 The land must stable and not subject to a high erosion risk, and coastal margins and stream banks must be presented in a stable and natural state, unless otherwise approved by the Manager.
- 10.7.1.6 Existing vegetation must be assessed for its appropriateness by the Council and where appropriate, retained and/or enhanced in a manner that does not hinder pedestrian or cycle access.
- 10.7.1.7 Unless agreed otherwise by the Manager, existing native riparian vegetation must be retained and any damage from pest plant removal or works will be minimised to the greatest extent practicable.
- 10.7.1.8 All land subject to earthworks must be covered with 150 millimetres of screened topsoil screened to 20mm sieve size and cultivated to form a true and even seed bed.
- 10.7.1.9 The site must be sown in an approved dwarf rye grass mix at a rate of 30 grams per square metre and lightly harrowed in and rolled to a compact and level surface with a minimum 80% self-sustaining healthy grass coverage. See also Chapter 4.15.2.
- 10.7.1.10 Grassed areas will be maintained free of pest plants and turf weeds for the duration of the two-year maintenance period and have been mown to 75mm height before maintenance is handed over to the Council.
- 10.7.1.11 The provision of any fencing and/or amenity plantings has prior approval of the Manager.
- 10.7.1.12 If required by the Council, reserves will be provided with a 20-millimetre diameter water service and a 100-millimetre diameter sewer connection supply to the boundary and an appropriately sized stormwater lateral connection.
- 10.7.1.13 Any reserves to be vested that include contaminated or potentially contaminated land, must comply with the National Environmental Standard for Assessing and Managing Contaminants in Soil to Protect Human Health (NES-CS). Any vesting of contaminated or potentially contaminated land – regardless of remediation status is subject to approval by the Manager.

- 10.7.1.14 Developers must provide the Manager with written notice prior to the reserve being sown with grass so an inspection can be undertaken. Written notice must also be provided a minimum of 2 months prior to the application for section 224(c) certificate approval for any stage of the subdivision that includes a reserve to vest. Notice is required so inspections can be undertaken and any remedial works required prior to the application for section 224(c) certificate.
- 10.7.1.15 Written notice from the Developer or the contractor undertaking the maintenance work must be provided to the Manager at the end of the two-year maintenance period so ongoing maintenance or other works can be provided for in the Councils' work programme.

Table 10-3 Nelson City Council Path, Track, and Road Category Standards within Reserves

Grade	Name	Use Suitability	Typical Examples	Formation, Width, Grade	Surface Material	Steps	Bridges / Culverts	Safety Rails and Barriers	Vegetation Clearance	Lighting	Furniture
1	Wheelchair Path	Wheel Chairs, Mobility Scooters, Pedestrians, Prams, Toddlers on bikes.	Queens Gardens	Well-formed even benched, with drainage W/T where needed. Legal width 6m unless agreed otherwise. Formation width 2.0 – 3m. Grade max. 5 deg. Over 9m distance followed by 1m flat rest area. The transverse gradient of crowned or banked footpaths or ramps will not exceed 1 in 50.	Paved or unpaved smooth surface.	Steps must have wheelchair bypass.	Required for all streams to prevent surface flow up to bridge/culvert design event across track and ensure safety of user groups.	Where a significant hazard to anyone exists, and cannot be avoided or mitigated. On one side of steps. Where there is a drop of >1m within 1m of track (as per SD420 and SD424).	From total track width, and to a height of 2.5m.	Lighting may be provided if the path is actively used at night.	Signs may be used to indicate directions, and times at entrance and junctions. Seats, picnic tables, bins, and platforms may be provided.
2	Path	Pedestrians, Cycles.	Fairfield Park Paths	Well-formed even, benched with drainage W/T where needed. Legal width 6m unless agreed otherwise. Minimum formation width 2 for a pedestrian pathway only and 2.5 – 3 for a shared path. Grade max. 10 deg. 15 deg. allowable over short distance (50m). The transverse gradient of crowned or banked footpaths or ramps will not exceed 1 in 50.	Paved.	Consistent run of steps allowable (three or more), max 0.18 height x 0.3m depth, at a maximum gradient of 45 deg. Provide landing every 20 steps.	Required for all streams, to prevent surface flow up to bridge/culvert design event across track and ensure safety of user groups.	Where a significant hazard to anyone exists and cannot be avoided or mitigated. On one side of steps. Where there is a drop of >1m within 1m of path (as per SD420 and SD424).	From total track width, and to a height of 2.5m. If path is shared use, 1m clear space buffer on both sides of the path between 1.2-2.5m high.	Lighting may be provided if the path is actively used at night.	Signs may be used to indicate directions, and times at entrance and junctions. Seats, picnic tables, bins, and platforms may be provided. To be set back at least 1m from path.
2a	Cycleway	Pedestrians, Cycles.	Railway Reserve	Same as above except width will be 2.5 - 3m.	Paved or unpaved.	No steps. Steps must have cycle bypass.	Required for all streams, to prevent surface flow up to bridge/culvert design event across track and ensure safety of user groups.	Where a significant hazard to anyone exists and cannot be avoided or mitigated. Where there is a drop of >1m within 1m of path (as per SD420 and SD424).	From total track width, and to a height of 2.5m. 1m clear space buffer on both sides of the path between 1.2-2.5m high.	Lighting may be provided if the path is actively used at night.	Signs may be used to indicate directions, and times at entrance and junctions. Seats, picnic tables, bins, and platforms may be provided. To be set back at least 1m from cycleway.
2b	Accessway path	Pedestrians, Cycles.		Refer to Chapter 4 Transportation for specifications.							
3	Short Walk	Walkers (Short stop travellers).	Maitai River	Legal width 6m unless agreed otherwise. Formed, or unformed. Width 1.4 – 2m. No obstacles on track. Grade max. 10 deg. 15 deg allowable over short distance (50m).	Paved or unpaved.	Allowable, max 0.18 height x 0.3m depth, at a maximum gradient of 45 deg. Provide landing every 20 steps.	Required over all major water courses. Required over minor water courses where they cannot be safely crossed by day walkers when in flood conditions.	Where a significant hazard to walkers exists and cannot be avoided or mitigated.	From total track width, and to a height of 2.5m. If path is shared use, 1m clear space buffer on both sides of the path between 1.2-2.5m high.	Not required.	Signs may be used to indicate directions, and times at entrance and junctions. Seats, picnic tables, bins, and platforms may be provided. To be set back at least 1 metre from walk where possible.
4	Walking Track	Mountain Bikes/ Walkers (Day Visitors).	Grampians, Branford Park	Legal width 6m unless agreed otherwise.	Gravel or natural ground / earth.	Allowable, max 0.18 height x 0.3m depth, at a maximum	Required over all major water courses. Required over minor water courses where they	Where a significant hazard to Mountain bikers/walkers exists,	Sufficient clearance to ensure the track walking surface,	Not required.	Signs may be used to indicate directions, and times at entrance and junctions.

				Formed or unformed. May have obstacles to avoid. Width 1.4 – 2m. Grade max. 15 deg. 20 deg. allowable over max. 100m distance.		gradient of 45 deg. Provide Landing every 20 steps	cannot be safely crossed by day walkers when in annual flood.	and cannot be avoided or mitigated.	the way ahead and furniture can be seen.		Seats, picnic tables, bins, and platforms may be provided.
5	Easy Tramping Track	(Back Country Comfort Seekers).	Dun Mountain Walkway	Legal width 6m unless agreed otherwise. Minimum 0.3m Minimum 0.6m where extra width is required due to steep drop offs etc.	Natural ground / earth.	Allowable max 0.18 height x 0.3m depth, at a maximum gradient of 45 deg.	Required over all major water courses.	Where a significant hazard to walkers exists, and cannot be avoided or mitigated.	Sufficient clearance to ensure the track walking surface, the way ahead and furniture can be seen.	Not required.	Signs may be used to indicate directions, and times at entrance and junctions. Seats, picnic tables, bins, not generally provided.
5a	Tramping Track	(Back Country Adventurers).	Water Reserves	Formed or unformed, markers used where track formation is unclear. May have obstacles to avoid. Legal width 6m unless agreed otherwise Formation width 0.3m in open flat country, – 0.6m where steep slopes and passing necessary. Grade max – none.	Natural ground / earth.	Allowable max 0.18 height x 0.3m depth, at a maximum gradient of 45 deg.	Required over water courses where they cannot be safely crossed by day walkers when in annual flood.	Where a significant hazard to walkers exists, and cannot be avoided or mitigated.	Sufficient clearance to ensure the track walking surface, the way ahead and furniture can be seen.	Not required.	Signs may be used to indicate directions, and times at entrance and junctions. Seats, picnic tables, bins, not generally provided.
6	Paved Roads & Car parks	2WD Vehicles, Mountain bikes, Walkers.	Maitai Valley Road	2 lane access, min. width 3m each lane and 1 footpath 1.4m wide. (Refer Chapter 4 Transportation for appropriate widths and grades). Grade max. 1 in 8 (7 deg).	AC, or chip seal to comply with Chapter 4 Transportation	No.	Required over all water courses.	To comply with Chapter 4 Transportation	To comply with Chapter 4 Transportation	Required as necessary to comply with Chapter 4 Transportation	Signs indicating directions, speed, to comply with Chapter 4 Transportation. Other furniture may be provided in appropriate places.
6a	Unpaved Roads	2WD Vehicles, Mountain bikes, Walkers, Horses.	Grampians Road	2 lane access, min. width 3m each lane and 1 footpath 1.4m wide. (Refer Chapter 4 Transportation for appropriate widths and grades). Grade max. 1 in 8 (7 deg).	Gravel, AC, or sealed To comply with Chapter 4 Transportation	Not allowable.	Required over most streams to prevent surface flow across road.	Not required.	From total road width, surface, and to a height of 2.5m.	Required as necessary to comply with Chapter 4 Transportation	Signs indicating directions, speed, required to comply with Chapter 4 Transportation Other furniture may be provided in appropriate places.
7	4WD Tracks	4WD Vehicles, Horses.	Sir Stanley Whitehead Park	Formed track, with water table drainage. Width 3 - 4 m. Grade max. 1 in 4 (14 deg).	Gravel, or natural ground / earth.	Not allowable.	Not required. Where currently existing, they will meet appropriate design standards.	Not required.	From total track width, and to a height of 2.5m.	Not required.	Signs indicating directions, distance, and to warn of other users. Other furniture may be provided in appropriate places.
8	Fire Breaks	Horses.	Marsden Valley Reserve	Formed track, with cut off drainage minimum 3m, but variable depending on a range of factors. No Grade restriction.	Natural ground / earth.	Not allowable.	Not required.	Not required.	No vegetation allowable above height of 150mm over full break width.	Not required.	Signs indicating directions, distance, and to warn of other users. Furniture may be provided as appropriate.

IF PLAQUE IS FITTED IT IS TO BE SET INTO THE CENTRE OF THE TOP BOARD SO THAT THE FRONT OF THE PLAQUE IS FLUSH.

LENGTH OF SEAT IS 1.8m WITH PIPE LEGS 300mm IN FROM EACH END.

CAP EACH END OF GALVANISED PIPE. PIPE IS 900mm LONG. BEND TO 100°.

EXCESS THREAD TO BE TRIMMED OFF AND ENDS PENNED OVER OR LIGHTLY WELDED TO REMOVE SHARP EDGES AND PREVENT REMOVAL.

120mm RADIUS

WELDS TO BE WIRE BRUSHED AND PAINTED WITH GREY ANTI RUST PRIMER PAINT SUCH AS COLDGALV.

CONCRETE PAD 2.2 x 1.0 x 0.1 STEEL FLOAT FINISH WITH EDGING TROWEL FINISH AROUND OUTSIDE EDGE. PAD TO HAVE 3% CROSSFALL TO DISPERSE RAIN.

40mm NOMINAL GALVANISED PIPE 740mm LONG. PRESS AND SHAPE TO FIT AT 93° AND WELD WITH 6mm FILLET ALL ROUND.

10mmØ GALVANISED COACH BOLTS. ROUND HEAD.

DRESSED EX 200 x 50 No.1 H3 TREATED PINE POPLAR OR MACROCARPA.

DRESSED 150 x 50 No.1 H3 TREATED PINE. POPLAR OR MACROCARPA

TIMBER TO BE PAINTED WITH RESENE LUMBERSIDER "DOC GREEN".

CHAMFER AND SAND ALL TOP EDGES.

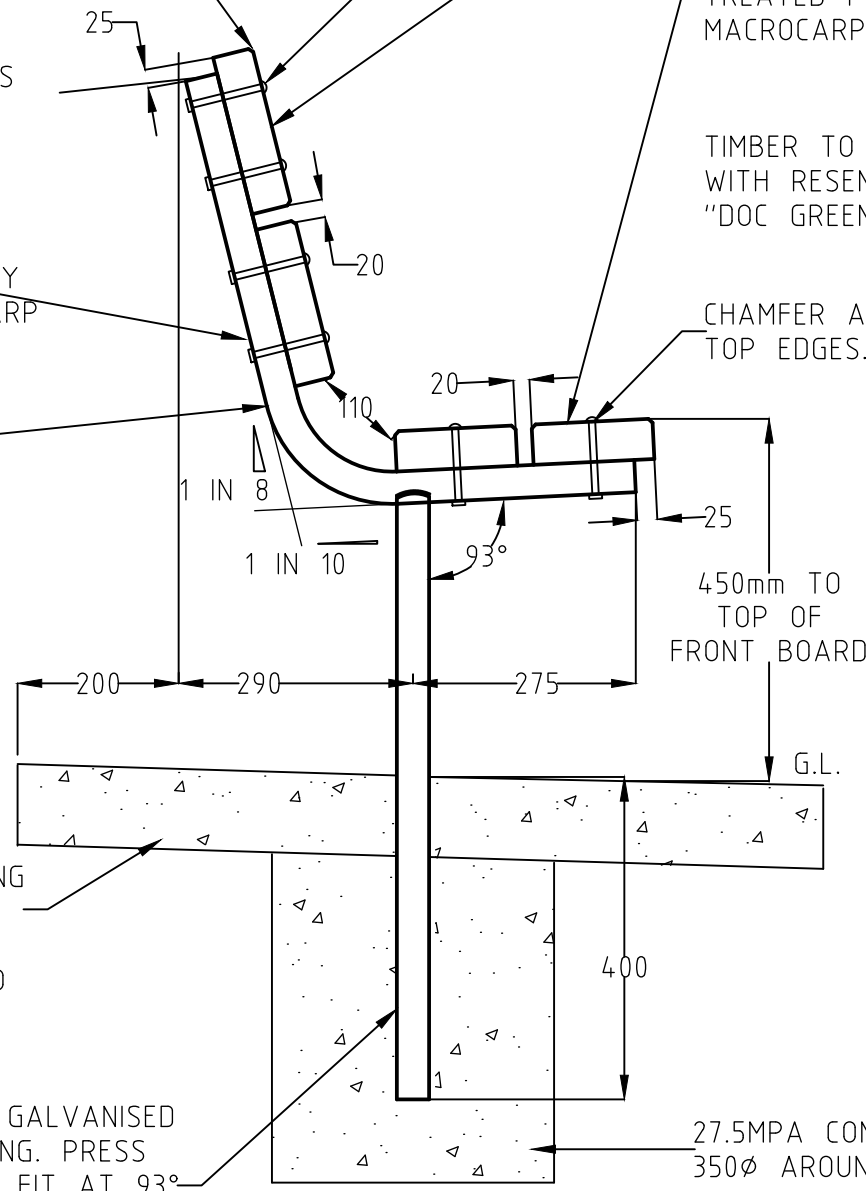

STEEL LEGS ARE TO BE BENT IN A HYDRAULIC PIPE BENDER WITH SUITABLE FORMER AND WELDED IN A JIG TO ENSURE UNIFORMITY.

NELSON CITY COUNCIL

GROUP MANAGER INFRASTRUCTURE, NELSON

STANDARD PARK BENCH

TASMAN DISTRICT COUNCIL

ENGINEERING SERVICES MANAGER, TASMAN

DATE

01/07/19

NELSON - TASMAN
LAND DEVELOPMENT MANUAL

1001



Appendix 1

Legal

TABLE OF CONTENTS

APPENDIX 1 LEGAL

INTRODUCTION	1
1.1 Liability.....	1
1.2 Indemnity.....	1
1.3 Excavation and Reinstatement works within legal road.....	2
1.4 Performance Bonds.....	2
1.5 Delegations.....	3
1.6 Location of Services.....	3
1.7 Services on Public Land.....	3
1.8 Services on Private Land.....	3

APPENDIX 1 LEGAL

INTRODUCTION

This appendix sets out Council's expectations for a number of legal matters, such as liability, indemnity and insurance, delegations, vesting, ownership and location of services. These are general requirements, and should be read in conjunction with the asset-specific requirements of each chapter.

1.1 Liability

The following sets out matters of liability and responsibility for any works involving an asset that is vested in or is to be vested in Council ownership.

- Council takes no responsibility for inaccurate information or unknown infrastructure found on site.
- Council will not be liable for any damages or loss whatsoever suffered from the use of information held by Council.
- All contractors/consultants must undertake other (such that there is a duty) field investigations that are necessary for surveyors/designers/owners etc to investigate fully/pothole to verify designs and correct positions of services etc.
- The consent holders, their employees, contractors and agents are responsible for physically locating the position of pipes and other utilities and infrastructure before commencing works.

1.2 Indemnity

All Designers or DPA's must have current professional indemnity insurance for an amount not less than:

Project	Professional Indemnity
In-fill development, not more than six lots or dwellings, no services vested to Council	\$300,000
In-fill development, not more than six lots or dwellings, and/or some services vested to Council	\$1,000,000
Green field development, more than six lots or dwellings where roads are vested to Council or services of \$500,000 or greater vested to Council	\$2,000,000

Any contractor/operator undertaking excavation and reinstatement works within any Council property will hold public liability insurance for an amount not less than five million dollars (\$5,000,000) for any claim or series of claims arising out of the same occurrence.

Compliance with any instruction of Council, or any person acting on its behalf, in performing what is considered to be necessary actions in terms of these standards will not absolve the contractor from any legal liability that he would otherwise have had in regard to claims for damage or failure of work for the client.

The Council will not be held liable for a loss of income due to construction works or loss of services while Council's contractors or agents work on programmed works.

1.3 Excavation and Reinstatement works within legal road

The contractor/operator will be held responsible for any street maintenance work required as a result of the excavation and reinstatement operations until twenty-four (24) months after notification to the Council that the final surfacing material has been applied.

Any such maintenance work required by Council will be undertaken by the operator at the operator's cost within five (5) working days of being notified by the Council to undertake repair works. If on the grounds of safety there is a need for more immediate action this remedial work will be completed within forty-eight (48) hours or such other time as may be directed by the Council. Should this not be complied with, Council reserves the right to arrange or undertake such maintenance work and this work will be at the cost of the operator.

See Chapter 8, Earthworks, Trenching and Reinstatement for further details.

For infrastructure, the Developer will retain responsibility for addressing defects arising from poor workmanship or faulty materials during a required maintenance period of at least 24 months following completion of works.

1.4 Performance Bonds

The Developer will provide a performance bond for unknown construction or design defects in cash or from a bondsman such as a registered bank (as defined in section 2 of the Reserve Bank of New Zealand Act 1989) or insurance company or other approved company, and meet the following conditions:

- The bond will apply to all subdivision or development construction works involving three or more additional lots or three new residential sites or where roads or services are to be vested in the Council.
- The bond for defects will be for the sum of \$1,500 per lot or residential site from a minimum of \$5,000 to a maximum of \$30,000 per stage, plus a bond administration fee of \$150. For significant infrastructure items that are to vest with council, an additional bond amount will be required. This amount will be set by Council's Engineering Manager.
- The term of the performance bond for defects liability will be for a minimum period of twenty-four (24) months from the satisfactory completion of the works (for contracts), or the issue of a 224 certificate as required under the RMA. Note: a maximum term of five (5) years may be imposed for low impact stormwater designs.
- The performance bond for defects will cover maintenance attributable to defects and the remedy of all defects arising from defective workmanship or materials.
- This will cover the services and roading construction works that are to be vested in the Council and other civil and structural engineering construction works to serve the subdivision or development and including electrical supply and telecommunication cable systems.
- The Developer/consent holder will be liable for the remedy of all asset defects arising before the end of the period of maintenance, together with Council costs in administering the bond. The developer will not be liable for damage by third parties.
- In the event that such a defect arises the Developer will be advised and, provided that the remedial work is not classified as urgent, given the opportunity to address the defect. Where urgent work is required to maintain service or where work on a 'live' system is required it will be carried out by Council's contractor at the Developer's cost.

- The performance bond for defects will not be required to cover general earthworks but will be required to cover any earthworks considered by Council to be part of the civil engineering construction.

1.5 Delegations

The Council has the authority to enforce the provisions of the Land Development Manual and may delegate such authority to any officer of Council or its nominated consultant.

1.6 Location of Services

This section deals with the location of services, and ownership responsibilities associated with all and any part of the service on privately-owned land, or privately-owned services on Council-owned land.

1.7 Services on Public Land

All reticulation will be located in accordance with the following general requirements:

- The preferred location of services to be vested in Council is on Council-owned land;
- All services will be aligned in accordance with the requirements of each section of this document.
- All services will be easily accessible for maintenance and repair works, so as to minimise disruption.
- Diagonal crossing of other services, including kerb lines and boundaries or fence lines, at acute angles less than 45 degrees will be avoided wherever possible.
- A minimum of 200mm vertical separation distance to all other underground services is required.
- Specific approval from the Engineering Manager will be required for any private services to be located within public land. Approval will be subject to a 'licence-to-occupy'.

1.8 Services on Private Land

The preferred location of services is on public land. However, this cannot be achieved in all circumstances, due to the location of existing infrastructure networks, land ownership and the topography of the landscape.

The following matters guide the placement of services on private land:

Where services are to be located on private land, consideration will be given to:

- Preserving access to the pipelines for maintenance purposes;
- Preserving the route for relaying services in the future; and
- Avoiding likely positions for buildings, garages, carports and retaining walls.

The preferred alignments of piped reticulation on private property will be:

- Within rights-of-way (ROWS) or driveways;
- Outside probable building envelopes;
- Clear of fence lines and kerb lines;
- Clear of large trees or heavily vegetated areas;
- Adjacent to boundaries;

- Parallel to boundaries; and
- On the northern side of lots.

Where a public or private service is located on private land access for repairs and maintenance will be maintained, and the following conditions met:

- An easement will be required in favour of the Council, where as part of a subdivision or development proposal, public drains less than or equal to 300mm diameter will be located in private property. The minimum width of easement will be 3.0m (Note: minimum 2.0 for rural water supply systems over farm land) with the pipe placed central within the easement. For public drains greater than 300mm diameter the minimum width of easement will be 3.0m plus the pipe diameter (i.e. 1.5m either side of the pipe).
- The standard wording required on engineering plans in the “notes” section, will be: “Memorandum of Easement in Gross will be provided in favour of Council to convey stormwater and/or wastewater in a pipe and to provide unrestricted access along the line of the pipe for maintenance and renewal work and to protect secondary flow paths”.
- Similar easements may be required over private common drains in favour of the lots served.
- Pipelines deeper than 2.5m will require easement widths greater than 3.0m plus pipe diameter to allow for wider than normal trench widths needed to access the pipe in the future.
- Where any construction work is required on another property, the owner’s consent will be endorsed on the original drawing in opaque black ink (not biro) that will permit satisfactory scanning reproduction.